

Environmental
Studies
Research
Funds

095 Evaluation of Hovercraft
for Dispersant Application

The Environmental Studies Research Funds are financed from special levies on the oil and gas industry and administered by the Canada Oil and Gas Lands Administration for the Minister of Energy, Mines and Resources, and by the Northern Affairs Program for the Minister of Indian Affairs and Northern Development.

The Environmental Studies Research Funds and any person acting on their behalf assume no liability arising from the use of the information contained in this document. The opinions expressed are those of the authors and do not necessarily reflect those of the Environmental Studies Research Funds agencies. The use of trade names or identification of specific products does not constitute an endorsement or recommendation for use.

Environmental Studies Research Funds

Report No.095

February, 1988

**EVALUATION OF HOVERCRAFT
FOR
DISPERSANT APPLICATION**

DF Dickins Associates Ltd.

S.L. Ross Environmental Research Limited

Seakem Oceanography Ltd.

Scientific Advisors: J. Swiss and I. Marr

The correct citation for this report is:

DF Dickins Associates Ltd., S.L. Ross Environmental Research Limited
and Seakem Oceanography Ltd. 1988. Evaluation of Hovercraft for
Dispersant Application. Environmental Studies Research Funds Report
No. 095. Ottawa. 57 p.

Published under the auspices of the Environmental Studies Research Funds
ISBN 0-920783-94-5

© 1988 - DF Dickins Associates Ltd.

S.L. Ross Environmental Research Limited
and Seakem Oceanography Ltd.

TABLE OF CONTENTS

	<u>Page</u>
ACKNOWLEDGEMENTS	vi
SUMMARY	1
INTRODUCTION	3
Background	3
Ship Based Dispersant Application	3
Aerial Dispersant Application	4
Hovercraft Dispersant Application	5
Study Objectives	6
Overall Study Approach	7
Study Team	7
STUDY METHODS	8
Literature Search	8
Oil and Dispersant Selection	9
Permitting and Approvals	10
Canadian Coast Guard Participation	11
Site Selection	12
Scheduling and Weather Limitations	16
Surface Oil Displacement	16
Test Description	16
Documentation	17
Mixing Energy	19
Experimental Design	19
Test Description	19
Deployment and Sampling Procedures	20
Dispersant Spray Pattern	24
Experimental Design	24

RESULTS	33
Surface Oil Displacement	33
Observed Oil Behavior	33
Surface Oil and Water Samples	33
Mixing Energy	37
Analytical Approach	37
Control Profiles	38
Experimental Profiles	40
Dispersant Spray Pattern	44
Drop Size Distribution	44
Dosage	47
DISCUSSION	50
Recommendations	52
REFERENCES	56
APPENDICES	
Appendix A - Literature Search Results, including Patent Descriptions	
Appendix C - Hovercraft Specifications	

LIST OF TABLES

<u>TABLE</u>	<u>Page</u>
1. Comparison of Oil Properties	9
2. Hovercraft Surface Effect Trials - Slick Data	36
3. Measured Dye Concentration	41
4. Dispersant Drop Size Analysis	45
5. Recommended Guide to Downwind Dispersant Application Speeds	54
6. Dispersant Treatment Capabilities of Representative Hovercraft	55

LIST OF FIGURES

<u>FIGURE</u>	<u>Page</u>
1. SR.N6 hovercraft operated by the Canadian Coast Guard	11
2. Location map for offshore tests	14
3. Dryland test location map	15
4. Canola oil being discharged off the bow of the hovercraft	18
5. High speed pass through the Canola oil slick	18
6. Hovercraft pass through Rhodamine dye cloud	22
7. Breaker board being towed through dye cloud	22
8. Fluorometer calibration curve	23
9. Underside view showing the skirt configuration of an SR.N6	26
10. General view of dispersant spray boom	28
11. Close-up view of dispersant spray boom	29
12. Dispersant tanks and spray pump	29
13. View showing the hovercraft approaching test strip	31
14. Laying out the Kromekote cards and collection trays across the hovercraft course	31
15. Two views showing the hovercraft proceeding at 21 knots through a dyed Canola oil slick (Run #5)	34
16. View over the side of the sample boat immediately following hovercraft passage	35
17. Profiles of control dye patches	39
18. Dye profiles	42
19. Scaled dye profiles	43
20. Dispersant drop size vs position	44
21. Example dispersant spray pattern	47
22. Dispersant dosage vs position	48

ACKNOWLEDGEMENTS

The authors would like to acknowledge the contributions to the study of the following individuals and agencies: Herb Buchanan of the Canadian Coast Guard Western Region, John McGrath, Fred Da Costa and the entire staff of the Canadian Coast Guard hovercraft base, Lorne Howell of the Vancouver International Airport, Keith Hebron of Environment Canada, and Dave Hope of Seakem Oceanography. Anthony Dickinson of DF Dickins Associates Ltd. organized the field trials and did much of the planning and procurement necessary to allow the field trials to proceed. Remote sensing was provided by Timberline of Vancouver.

This report was written by David Dickins of DF Dickins Associates Ltd., Randy Belore and Ian Buist of S.L. Ross Environmental Research Limited, and Blair Humphrey of Seakem Oceanography Ltd.



SUMMARY

A series of field trials were carried out in Vancouver, Canada in July and August 1986 to determine whether or not hovercraft should be considered for dispersant application. Critical questions centred around 1. the ability of the hovercraft to "fly" over an oil slick at high speed without displacing the oil out of the path, 2. the potential for using the hovercraft to impart vertical mixing energy into the water column to aid in the dispersion process and 3. the ability to mount a suitable spray boom and obtain a uniform spray pattern across the swath width.

The field trials and subsequent interpretation of results provide positive answers to questions 1. and 3. The question of mixing energy requires some qualification; the hovercraft contributes considerable mixing energy to the immediate water surface through air entrainment but this effect is short lived and there does not appear to be significant long term vertical mixing in the hovercraft wake.

Recommendations are made in the report for operating procedures and boom mountings which should ensure a uniform drop size and dose rate across a swath width up to 18 m. The cushion air escaping from around the craft perimeter is not an important factor in adversely affecting the dispersant spray pattern.

Depending on the type of machine available, hovercraft have the capability of treating up to a 1 km² slick between loads, at average speeds in the 15 to 25 knot range. The inherent advantages of high transit speed to the site (up to 45 knots), amphibious operation (i.e. not draft limited) and lack of ceiling or visibility restrictions provide hovercraft with unique capabilities in the dispersant application role.

RÉSUMÉ

Une série d'essais sur le chantier a été réalisée à Vancouver, au Canada, en juillet et en août 1986 afin de déterminer les possibilités d'utiliser des aéroglisseurs pour l'application de dispersants. Parmi les principaux points qui ont été étudiés figurent 1. la capacité de l'aéroglisseur de "voler" au-dessus d'une nappe de pétrole à grande vitesse, sans toutefois déplacer le pétrole de sa trajectoire 2. les possibilités d'utiliser l'aéroglisseur pour créer des courants de turbidité verticaux de façon à mieux répandre les dispersants et 3. les possibilités de monter un barrage de pulvérisation de façon à obtenir un jet uniforme sur toute la largeur de la nappe de pétrole.

Les essais sur le chantier et l'étude subséquente des résultats ont confirmé les points 1 et 3. La question des courants de turbidité verticaux demande, pour sa part, certaines améliorations. L'aéroglisseur crée une quantité considérable de courants de turbidité à la surface immédiate de l'eau au moyen de l'entraînement de l'air, mais l'effet est de courte durée. Il ne semble pas y avoir de courants de turbidité verticaux à long terme à la suite du passage de l'aéroglisseur.

Le rapport renferme une série de recommandations relatives aux procédures d'exploitation et au montage des barrages de pulvérisation pour assurer une dimension des gouttes et une concentration du dosage uniformes sur une nappe d'une largeur maximum de 18 m. Le coussin d'air qui se dégage autour du périmètre de l'aéroglisseur ne menace aucunement le jet de dispersant.

Selon le type d'appareil utilisé, les aéroglisseurs peuvent traiter une nappe de dimension maximum de 1 km² à des vitesses moyennes de 15 à 25 noeuds avant que le réservoir de dispersant ne doive être rempli à nouveau. Vu les avantages évidents de leur très grande vitesse de déplacement sur les lieux d'un déversement (jusqu'à 45 noeuds), les possibilités offertes par leur nature amphibie (l'appareil n'est pas limité par les tirants d'eau) et l'absence de restrictions quant au plafond et à la visibilité, les aéroglisseurs possèdent des capacités uniques leur donnant un rôle d'avant-plan dans l'application de dispersants.

INTRODUCTION

This study was conceived as a logical response to industry interest in using hovercraft as potential oil spill response vehicles capable of high speed dispersant application off Canada's east and west Coasts as well as in the Arctic.

BACKGROUND

Ship Based Dispersant Application

The development of specialized equipment for the application of chemical dispersants to oil slicks at sea has been ongoing since the late 1960's. Warren Springs Laboratory (WSL) pioneered the development of specialized tug-mounted dispersant spray gear (Smith 1969) and the concept has changed very little since that work. Subsequent effort in the design of offshore dispersant spray gear has generally centred on simpler methods of rigging the booms to ships of opportunity or to dedicated work boats, and on better dispersant delivery pumps and metering systems.

The basic configuration of all systems remains the same. Spray booms (up to 5 to 6 metres long) are rigged at right angles to the side of the ship and elevated from the water's surface to prevent their submerging during vessel roll. Flat fan nozzles are pointed aft at about 30° from vertical and spaced to achieve slight overlap at the water's surface. Discharge pressures and orifice diameters have generally been selected to give a uniform pattern of fairly large drops to prevent wind drift and improve the coverage of the oil slick. The WSL shipmounted spray systems were originally developed for the application of conventional dispersants, and subsequently adapted for use with dispersant concentrates through the addition of a small metering pump that diluted the concentrate with sea water before application. Other systems have been developed for the direct application of the low mix dispersant concentrates.

Many methods have also been tested to aid the dispersion process by mechanically mixing the dispersant-oil-water system. Such techniques include prop-wash, fire hoses, and towed pallets or breaker boards (Smith 1969; IMO/UNEP 1982). The use of relatively high-pressure, low-volume water jets to assist the mixing process has been studied in the laboratory but not tested in the offshore (Belore 1986). When additional mixing is required, use of the WSL breaker boards remains the preferred method, although the recently developed low-mix dispersants were designed to eliminate the need for this mixing.

Aerial Dispersant Application

The ship-based application of dispersants has generally been considered to be an effective method of applying dispersants to small spills; the technique becomes severely limited by logistical constraints for larger spills where wide expanses of oil are present. For this reason most of the recent work on dispersant application has focused on aerial application methods.

Extensive research has been carried out on the feasibility of applying dispersants from fixed wing aircraft and helicopters. Effort has concentrated on developing spray systems that maximize the amount of dispersant reaching the target oil slick (i.e., minimizing wind drift) without generating drops of such a large size that they pass through the oil slick (Mackay et al. 1980; Kristmanson et al. 1981; Lindblom and Barker 1979; Lindblom and Cashion 1983).

Several successful systems have been developed to apply dispersants from aircraft ranging from DC-6's and Hercules, to smaller fixed wing agricultural spray craft, to helicopters with underslung spray systems. Unfortunately, the effectiveness of

aerially applied dispersants has been somewhat disappointing during a number of large experimental spills (Fingas 1986; Belore 1987). In general, the dispersion observed in the field has been less than anticipated from laboratory studies. Several theories have been put forth in an attempt to account for these results but such speculation is beyond the scope of this report. The discrepancies between laboratory and field results may be related to inefficient dispersant formulations, improper application methods, or a combination of both factors. Interpretation of the results of dispersant testing is further complicated by the different physical environments represented by bench top testing devices and the open ocean.

Hovercraft Dispersant Application

Hovercraft have many advantages in the dispersant application role when compared with either aircraft or ships. Gill (1978) outlined a number of the hovercraft's capabilities in the oil spill response role. These and others are outlined as follows:

1. Hovercraft operate without regard for water depth, and can reach delta marshes, inundated tundra and intertidal areas otherwise accessible to spraying only by aircraft or helicopter.
2. Hovercraft are capable of safe operation in fog and low ceiling conditions which would ground aircraft and helicopters.
3. Hovercraft offer potential for greater control over the spray pattern than possible through aerial means, and more effective dispersant application to localized spills or parts of a spill.

4. Hovercraft can maintain a high transit speed to a spill incident in sea states up to 3 m. In calm conditions this advantage translates to a 5:1 time saving over conventional displacement vessels and in rougher water, the hovercraft will still maintain a 3:1 speed advantage.
5. Hovercraft can potentially apply dispersant at much higher speeds than possible from any other surface vessel.
6. Hovercraft offer a much greater dispersant payload than is possible with existing commercial helicopters, and can carry this payload at substantially lower hourly operating rates.
7. In the arctic, hovercraft offer the capability of responding to an open water spill incident in the polynya zone, even though transit to the spill site may involve travel over solid ice from the shore base. Once on site, the hovercraft can operate in broken ice which would severely hinder or prevent operations with conventional vessels.

Previous work by Gill(1978) showed that suitable spray gear can be rigged and deployed from a hovercraft. Meikle (1978) showed that as long as the hovercraft was flown on full cushion, the oil was not displaced or blown out of the way (observations were limited to low speed only with the hovercraft at less than 10 knots).

STUDY OBJECTIVES

This study is concerned primarily with confirming the high speed effectiveness of hovercraft, which constitutes the characteristic of most interest to oil spill response personnel. The overall study objective was to determine, through a series

of basic observations, whether or not there was merit in recommending further field trials with hovercraft spraying dispersant over an actual oil spill offshore.

The study objective was met by testing three hypotheses:

1. That a hovercraft can be operated through an oil slick at high speed (>20 knots) without causing significant lateral displacement of the oil to one side (i.e. out of the way of the dispersant)
2. That a hovercraft will impart sufficient mixing energy into the water surface to assist with oil dispersion under calm conditions.
3. That dispersant sprayed out ahead of the vehicle will contact the sea surface with a uniform areal density and drop size across the intended swath width.

OVERALL STUDY APPROACH

Study Team

The study team was comprised of three companies having the following responsibilities:

DF Dickins Associates Ltd.

- Prime Contractor and Project Director, responsible for permits and approvals, logistics, hovercraft monitoring, documentation of environmental conditions and final report preparation

SL Ross Environmental Research Limited

- Subcontractors responsible for documentation and analysis of oil and dispersant behaviour through surface sampling and aerial photography and for specifying and evaluating the spray system

Seakem Oceanography Ltd.

- Subcontractors responsible for design, documentation and analysis of the tests aimed at measuring surface mixing energy in a hovercraft wake relative to breaker boards and natural sea disturbance

Study Phases

The study was divided into three distinct phases:

1. A literature search was carried out to identify any previous work describing either the interaction of a hovercraft with an oil slick and/or the application of dispersants from a hovercraft.
2. Permits and approvals were obtained from federal agencies to allow discharge of Canola oil offshore, and dispersant on land.
3. Field trials were designed and executed to investigate the three hypotheses outlined above.

STUDY METHODS

LITERATURE SEARCH

A comprehensive literature search was conducted using key words SPRAY (nozzle, application, system), AIR CUSHION VEHICLE (ACV or hovercraft), OIL, and DISPERSANT. In addition, a patent search was carried out which discovered a number of related applications (Appendix A).

The literature search revealed that no previous work had been done which fully met the objectives of this study. Past trials concentrated on stern and side mounted spray booms (Gill, 1978). Actual observations of the interaction between a hovercraft and an oil slick were limited to a spill of opportunity encountered at low speed (Meikle, 1978).

The decision was made to proceed with a series of preliminary field trials aimed at evaluating the prospects for high speed dispersant application across the bow of a hovercraft.

OIL AND DISPERSANT SELECTION

The offshore components of the field trials were designed around the use of Canola oil as a crude oil substitute. Canola oil (commonly known as rape seed oil) is a non toxic vegetable oil used in the food industry for the manufacture of margarine. Canola oil has been used in numerous trials to simulate crude oil (see Allen and Nelson, 1983). The following table compares a number of physical properties of Canola oil and Alberta Sweet Mixed Blend crude oil.

Table 1. COMPARISON OF OIL PROPERTIES

<u>Property</u>	<u>Canola Oil</u>	<u>Alberta Sweet Mixed Blend</u>
Density @ 10°C (kg m ⁻³)	935	840
Viscosity @ 15.6°C (mPa s)	60	10
Oil/Interfacial Tension @ 25°C (mN m ⁻¹)	11	20
Vapour Pressure @ 37.8°C (kPa)	18.6	0
Emulsion Formation Tendency	Not Likely	Likely
Emulsion Formation Stability	Not Likely	Likely

Ocean dumping regulations for Canadian waters discourage the introduction of dispersant or oil into the marine environment regardless of the volumes involved. The permits necessary to

discharge dispersant offshore could not be obtained within the desired project schedule. Consequently, the third field trial was designed as an overland test.

During the first field trial, the Canola oil was premixed with an oil soluble Sudan III dye to increase the visibility on the surface and from the air. Water soluble Rhodamine B dye was used in the second and third field trials.

The dispersant used in the third field trial was Corexit 9527. This product is commonly stockpiled across Canada by the Coast Guard and has been used in numerous sea trials. In the third field trial, dispersant was premixed with Rhodamine B dye to leave a clear record on the Kromekote cards.

PERMITTING AND APPROVALS

Once the selections of a crude oil substitute, dyes and dispersant were finalized, the study team undertook to procure a permit under the Environment Canada Ocean Dumping Control Program (Appendix B). Additional authorization for the offshore trials was also required from the Canadian Wildlife Service under Section 35 of the Migratory Birds Convention Act. One of the terms of this authorization specified a short aerial reconnaissance flight with a CWS representative onboard, prior to discharging the Canola oil.

The dryland test was carried out with the written approval of the Vancouver Airport manager on the understanding that the grass would not be killed or damaged by the dispersant and that the area would be flushed with clean fresh water following the test.

CANADIAN COAST GUARD PARTICIPATION

The Canadian Coast Guard co-operated fully with the study team by providing an SR.N6 hovercraft from their Sea Island (Vancouver International Airport) Search and Rescue base (Figure 1).

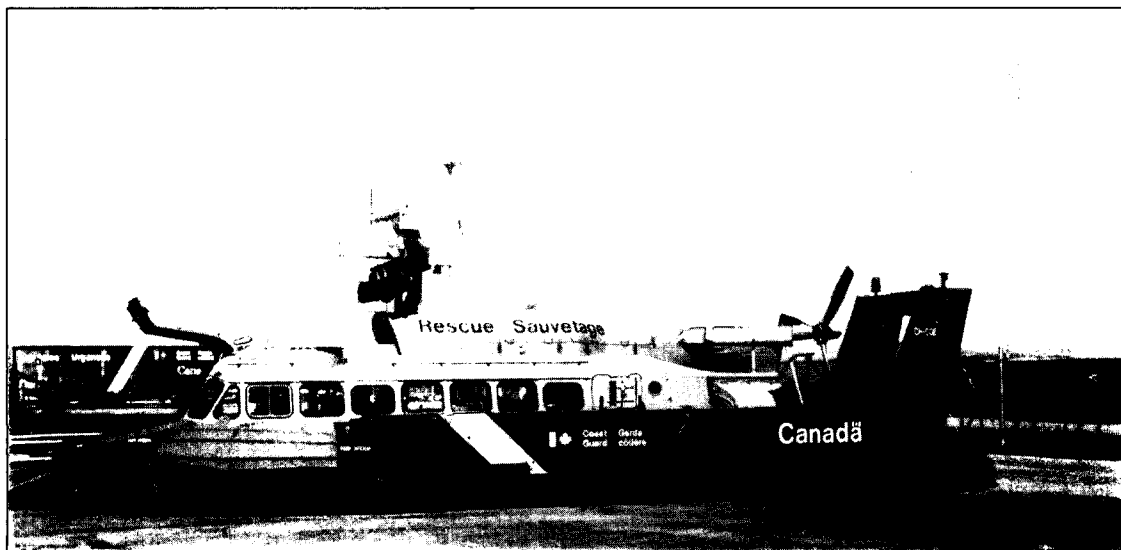

Figure 1. SR.N6 hovercraft operated by the Canadian Coast Guard

There are only six large hovercraft operated in Canada with the necessary payload capability to act as practical dispersant carriers: 3 SR.N6's in Vancouver (3.2 tonnes), 1 Bell Voyageur in Montreal (20 tonnes), 1 BHC AP.1-88 in Montreal (10 tonnes) and the Wartsila Larus in Tuktoyaktuk, N.W.T.. All machines with the exception of the Larus are operated by the Canadian Coast Guard.

The SR.N6 used in this study is a 1960's design with a single gas turbine of 900 hp driving both the lift fan and propeller through a split gearbox. The craft has a maximum calm water speed of 60 knots and a typical patrol cruise speed of 30 knots

providing an endurance of approximately six hours. The operating area includes the Strait of Georgia, Fraser River, Gulf Islands and Vancouver Harbour. The maximum payload is 7000 lb, of which 3000 lb can be carried externally on two flat side decks.

Limiting operating weather conditions for patrols are a significant wave height of 1.5 m and winds in excess of 35 knots (the craft routinely operate in worse conditions in the event of a search and rescue incident). These sea state limits apply to the case where there are short breaking seas or where the wavelength is less than 1.5 x the craft length, i.e. about 22 m. For longer waves the height becomes progressively less important. The limiting wind speed is also related to the available open water fetch that the craft is exposed to. For example, with 12 miles of open water upwind of the craft, the limiting windspeed is reduced to 30 knots, and with 25 miles, the speed is further reduced to 25 knots. Specifications and general arrangement drawings of the SR.N6 and other Coast Guard hovercraft are included in Appendix B.

SITE SELECTION

Figure 2 shows the proposed test site which was eventually used for both offshore trials. A number of constraints entered into the final selection of the offshore site.

- Canola oil must be spilled outside the Fraser River estuary (i.e. not on Sturgeon Bank), away from intertidal areas and away from marinas or sports fishing areas.

- The test site must be within approximately 35 km of the hovercraft base so as not to interfere with the primary search and rescue (SAR) mission. The hovercraft was provided with the understanding that SAR had priority over all other work

and that the tests would be interrupted in the event of a conflicting SAR incident. These interruptions occurred several times during the tests.

The dryland site was located immediately adjacent to the hovercraft base on Vancouver Airport property (Figure 3). The available maneuvering area was limited by a ditch to the east and a runway to the north. The useable flat area was approximately 600 m in length, oriented NW/SE.

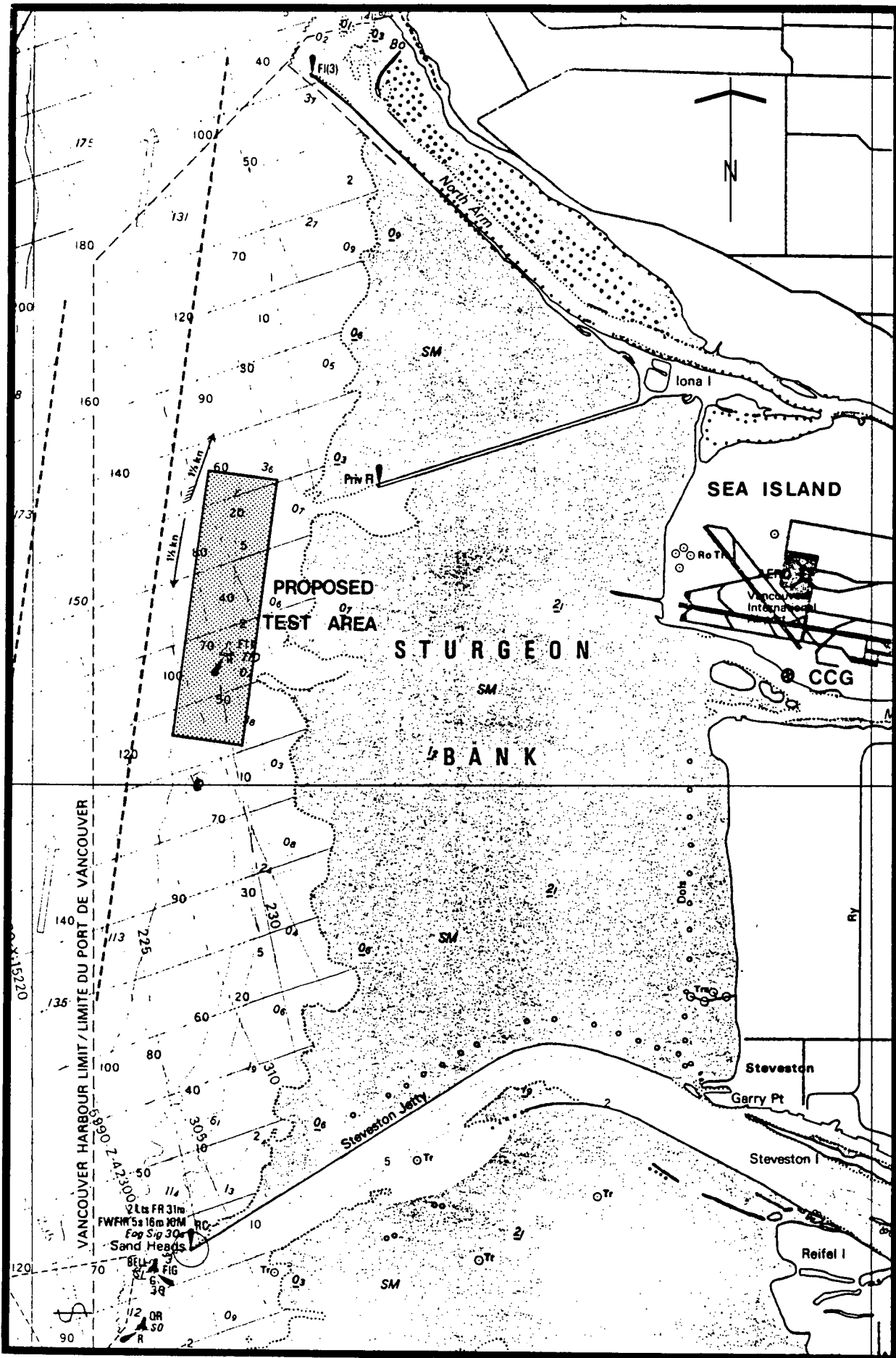
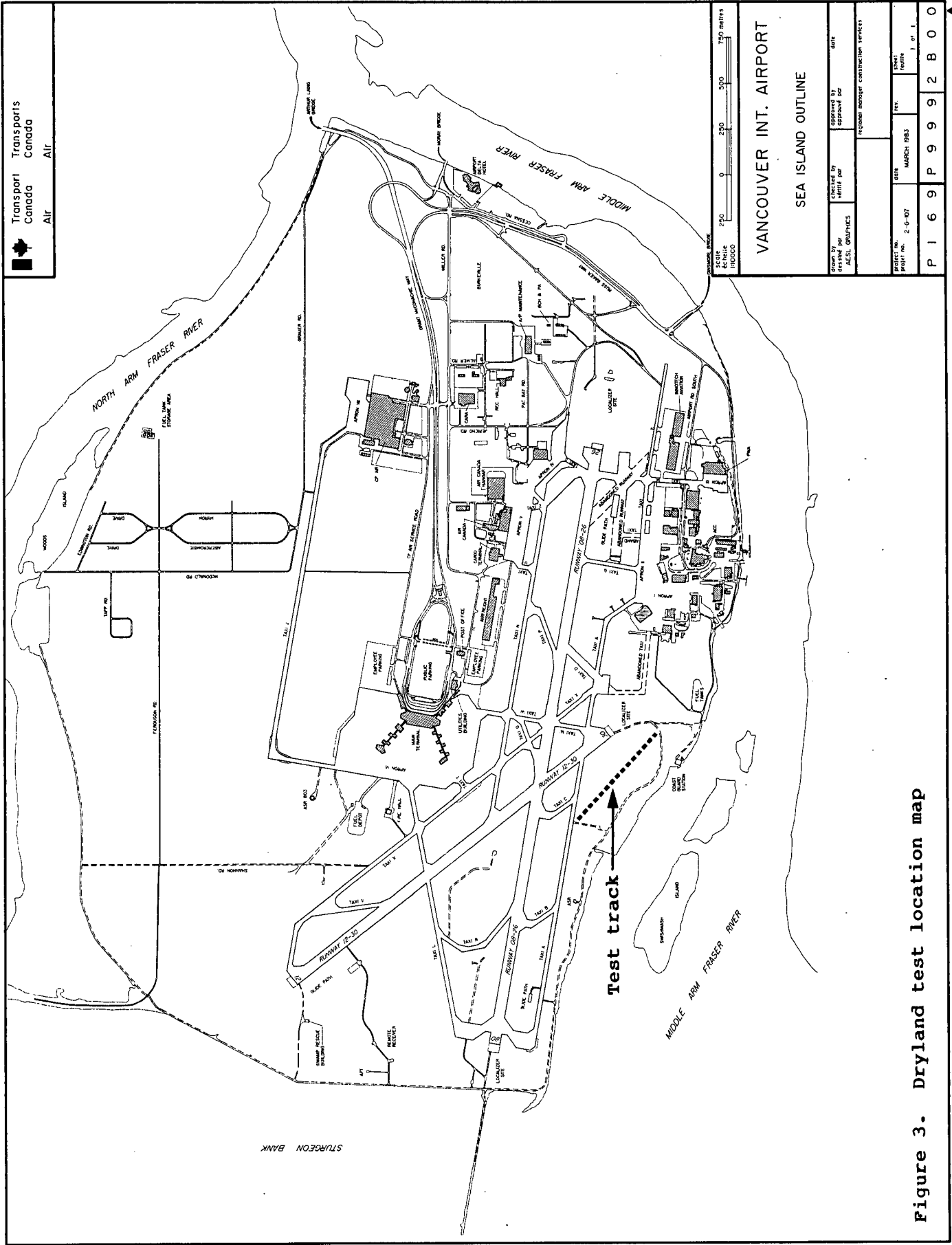

Figure 2. Location map for offshore tests Scale 1:80 000



Transportis
Canada
Air



SCALE: 1:10000
250 500 750 METRES

VANCOUVER INT. AIRPORT
SEA ISLAND OUTLINE

Drawn by JCSL Graphics	Checked by JCSL Graphics	Approved by [Signature]	Date
Project no. 2-G-007	Sheet MARCH 1983	Rev. 1 of 1	
PI 69 P 9992800			

Figure 3. Dryland test location map

SCHEDULING AND WEATHER LIMITATIONS

The field tests were scheduled for the spring or summer months from April to September to maximize the chances of fair weather. Preferred conditions to minimize possible fouling of the intertidal area, were an ebb tide with a light offshore breeze (rare).

Environmental limits were directly related to a desire for calm conditions (so as to maximize the relative differences between disturbances directly attributable to the hovercraft and disturbances related to prevailing sea conditions), and good visibility for aerial photography and surface observations.

SURFACE OIL DISPLACEMENT

Test Description

The first field trial took place on July 9, 1986 in the Strait of Georgia at approximately 49°10' N x 123°26' W. A total of 208 L of Canola oil premixed with Sudan III dye was discharged in three batches (32 L, 64 L, 112 L) over a three hour period by pouring directly over the bow of the hovercraft as it moved slowly backwards on partial cushion (Figure 4).

Nine runs were carried out with the hovercraft passing over the Canola oil slick at speeds ranging from 10 to 37 knots (refer to Table 2). Hovercraft pitch trim was varied from bow up to bow down (relative to normal operating attitude) in an effort to see if dragging different parts of the skirt and altering the point of maximum cushion air leakage would affect the pattern of surface oil disturbance.

Figure 5 shows the hovercraft during one of the first runs through the Canola slick. The damping effect of the oil on the waves in the area is visible in the photograph. Wind and sea

state gradually increased throughout the trial from 5 mph and a 1 ft chop to 14 mph and a 2 ft swell.

Foam slabs with marker flags were set out to mark each run through the slick for the hovercraft captain, the sample boat and the helicopter.

Documentation

The surface effect of the hovercraft passing over the oil slick was documented by aerial photography, slick thickness measurement and in-water oil concentrations. The aerial photography consisted of true-colour 70 mm still photos and a video record. (refer to Figure 15 in *RESULTS*).

The true-colour photos and video record provide an excellent overall view of the hovercraft wake and provide a continuous time history. However, these data cannot be used to quantify the surface effects in any way. Surface oil thickness was estimated before and immediately after the passage of the hovercraft by sorbing a known area of the surface oil and subsequently extracting and analysing the quantity of oil taken up by the sorbent (see Belore, 1982 for a complete description of the technique). In-water oil concentrations, before and after the passage of the hovercraft, were determined by taking 125 ml grab samples of water from the upper 30 cm of the water column. The quantity of oil in each sample was determined by extracting the oil with a colourless solvent and colourimetrically determining the quantity of oil in each extraction.



Figure 4. Canola oil being discharged off the bow of the hovercraft



Figure 5. High speed pass through the Canola oil slick

MIXING ENERGY

Experimental Design

The dye experiment was designed to evaluate the nature of the mixing energy that a hovercraft may apply to the water surface, and which would be available for mixing dispersed oil down into the water column.

A concentrated cloud of dye in the water was overflowed by the hovercraft after which vertical dye concentration profiles were determined. A similar test was then conducted with a small boat towing a breaker board. Both test results were subsequently compared with profiles obtained in a control dye patch.

Test Description

Arrangements were made to have a hovercraft and a small vessel equipped with a breaker board at a site close to that used in the previous test (Figure 1) on 15 July 1986. The day was suitably calm, and mobilization took place by 1230. Two 0-2 m windowshade drogues were placed about 100 m apart in a north-south direction. A spray system was used to place a long narrow cloud of dye on the surface of the water from about 10 m outside the drogue line on the south, to 10 m beyond the north drogue. While the fluorometer was being set up, the hovercraft was called away on a search and rescue mission. After its return, a smaller scale test was set up; a concentrated cloud of dye was placed about the northern drogue, the hovercraft was flown over part of the cloud and dye concentration profiles were determined.

After the hovercraft test, a similar test was performed at the southern drogue, with the vessel towing the breaker-board passing through part of the cloud. Dye concentration profiles were again determined.

Both the hovercraft and breaker-board vessel had to return to their bases at this point, so no additional experiments were possible.

Deployment and Sampling Procedures

A small scale spray bar system was initially set up to spray saturated dye solution over a swath 1 m wide. The system included 1/2" polyethylene tubing with 1 mm holes every 10 cm. This system failed after the trial spraying as fine dye particulate clogged the openings.

The Rhodamine dye was next applied to the water surface over a small area by pouring a saturated solution of dye in sea water slowly onto the surface while travelling in the rubber boat. For each test, the dye was spread over a 15 m by 2 m area on each side of a 0-2 m drogue, on a line connecting two drogues. The hovercraft test took place at the northern end of the drogue line, between the drogues, while the breaker board test took place at the south end of the drogue line, between the drogues. The dye outside the drogues was used as controls for each test. In each test, the dye was placed five minutes before the test began.

Three dye placements were made, totalling 150 g of Rhodamine B dissolved in 15 L of seawater. The first was not used as the hovercraft was called away immediately after the dye was placed. The second placement was made by pouring directly from a bucket at 1515, at the north drogue. The hovercraft made an initial pass, but missed most of the dye. During the second pass, the hovercraft passed directly over the dye next to the drogue (Figure 6). Dye coloured water was seen to sweep from the side of the hovercraft, and a clearer path was left in the dye cloud. Subsequent dye measurements were made in the area in which dye

remained. The third placement took place at the south drogue at 1540. The breaker board was pulled through the cloud. There was considerable turbulence observed from both the vessel propeller and the breaker board, and the dye was visibly mixed (Figure 7)

Dye concentrations were measured using a Turner Designs Model 10-005 fluorometer fitted with a Rhodamine filter kit and flow-through cell. The Rhodamine filter kit consists of quartz lamp, a 546 excitation filter, a 23A/3-366 combination emission filter, and a 16 reference filter.

During the field tests, water was pumped from selected depths using a Little Giant submersible pump, through 1/2" polyethylene tubing, into the fluorometer. The tubing was shielded for one meter on the inlet and outlet ports of the fluorometer using heavy black plastic, to avoid scattered light interference to the photomultiplier tube. Validation samples were collected periodically from the outlet port for later laboratory confirmation. Both the fluorometer and the pump were powered by a Honda 600 watt gasoline generator on board the Zodiac.

During each trial, profiles of dye concentration vs. depth were measured while time permitted. The dye clouds were marked by the drogues so the vessel could return to the approximate water mass.

For the hovercraft test, one control and three experimental profiles were made. For the breaker board test, two control and three experimental profiles were made. Further profiling was not possible as a current change caused general mixing of the water column and no dye patches were found.



Figure 6. Hovercraft pass through Rhodamine dye cloud



Figure 7. Breaker board being towed through dye cloud

After the field tests were complete, the fluorometer was returned to the laboratory and recalibrated. The validation samples were measured using the same fluorometer equipped with a cuvette cell.

The calibration curve for the fluorometer is shown in Figure 8. A second order calibration curve is used to accommodate the self-quenching characteristics observed over the wide range of measured concentrations.

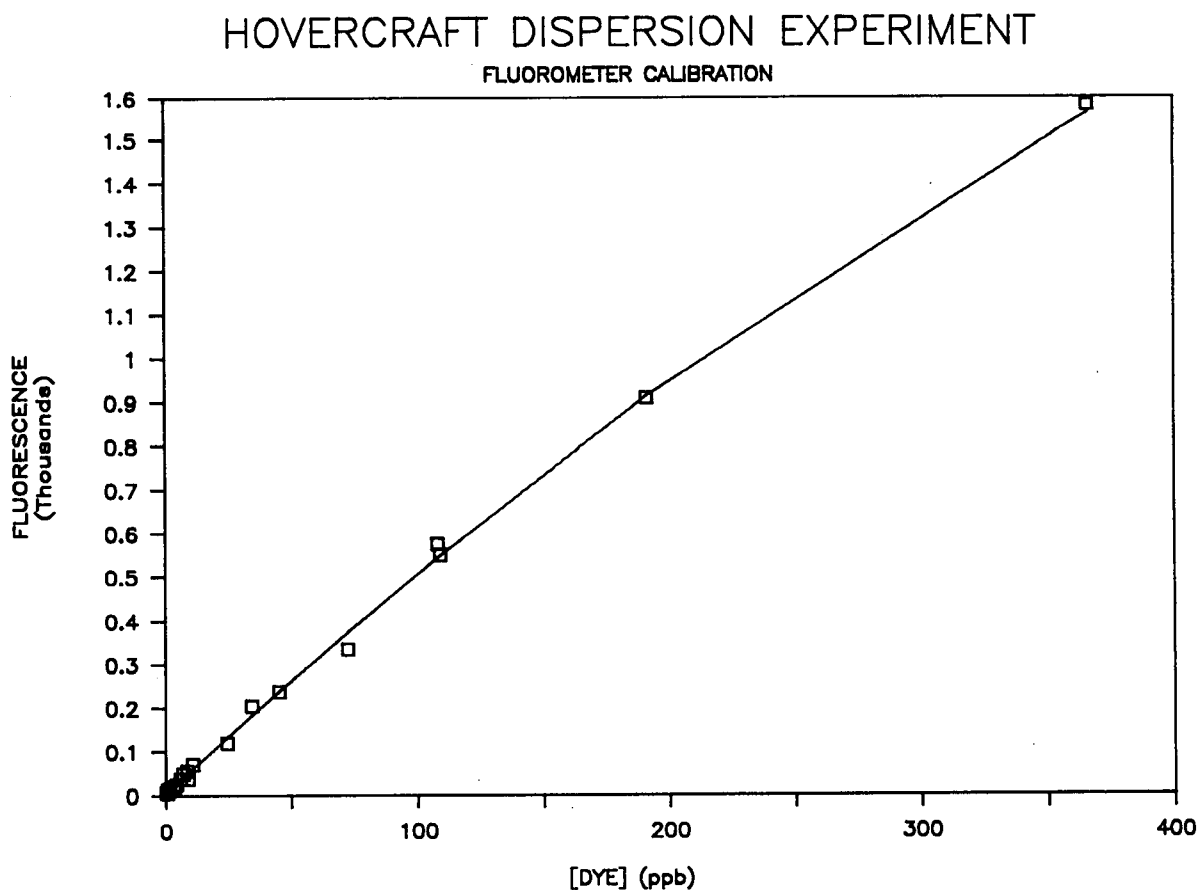

Figure 8. Fluorometer calibration curve

DISPERSANT SPRAY PATTERN

Experimental Design

Theoretically, the ideal spray system generates small dispersant drops and distributes all of them, with no losses, to the thick portions of the oil slick. This allows the dispersant to be applied uniformly to the slick, and results in a maximum contact and interaction of dispersant with the oil. This "ideal system" is impractical however, because very small drops are more susceptible to wind drift; consequently, a substantial portion of the dispersant misses the target oil.

Therefore, a practical system should produce dispersant drops large enough that they are not carried away from the target oil by the wind, but not so large that they either penetrate the oil slick or do not provide a uniform coverage of the slick because of a small number of large drops.

Using a hovercraft to apply dispersant may be advantageous in terms of dispersant dosage and drop-size distribution. With a hovercraft, as opposed to a conventional ship, the spray boom can be mounted closer to the water since the hovercraft has much less roll even in significant seas. With the spray boom mounted closer to the water, the dispersant is less likely to be blown away by wind prior to it hitting the target oil slick. It may therefore be possible to use smaller dispersant drop-sizes in a hovercraft system and still achieve good slick dosing with minimal losses.

Following successful completion of the two offshore trials, a dispersant spray boom was fabricated to mount ahead of the bow of the hovercraft in preparation for a third field trial involving dispersant sprayed over dryland. Four possible locations for mounting the spray boom were considered before finalizing on the bow installation: 1. across the bow, 2. off

the side as outriggers, 3. inside the cushion (plenum) chamber flush with the hull underside, and 4. across the stern.

Option 4 was not seriously considered because it automatically implies that the dispersant is introduced to a previously disturbed surface (maximum dispersant effectiveness requires that the surface be disturbed after the dispersant lands).

Option 2 offers the potential for maximum swath width but sacrifices the benefits of surface mixing energy provided by the hovercraft passage. Side booms may be preferred under moderately rough water conditions where the mixing energy introduced by the hovercraft becomes insignificant compared with the naturally available energy at the sea surface. In this way, the available swath width can be increased from about 8 m to 18 m.

Option 3 (internal mounting) was not practical with the SR.N6 because the clear hull beam available between the side skirt bags and the longitudinal keel was inadequate to mount a spray boom of any practical length (refer to Figure 9 for clarification). The landing pads also offered insufficient clearance to protect the boom from being crushed on landing. It may be possible to mount the spray boom internally on a different hovercraft with greater clear hull beam available and deeper landing pads. Such an installation would have definite advantages over any external mounting. For example, the spraying would take place in a calm environment isolated from the effects of wind and sea. The installation could be left permanently in place without interfering with the hovercraft's other missions.

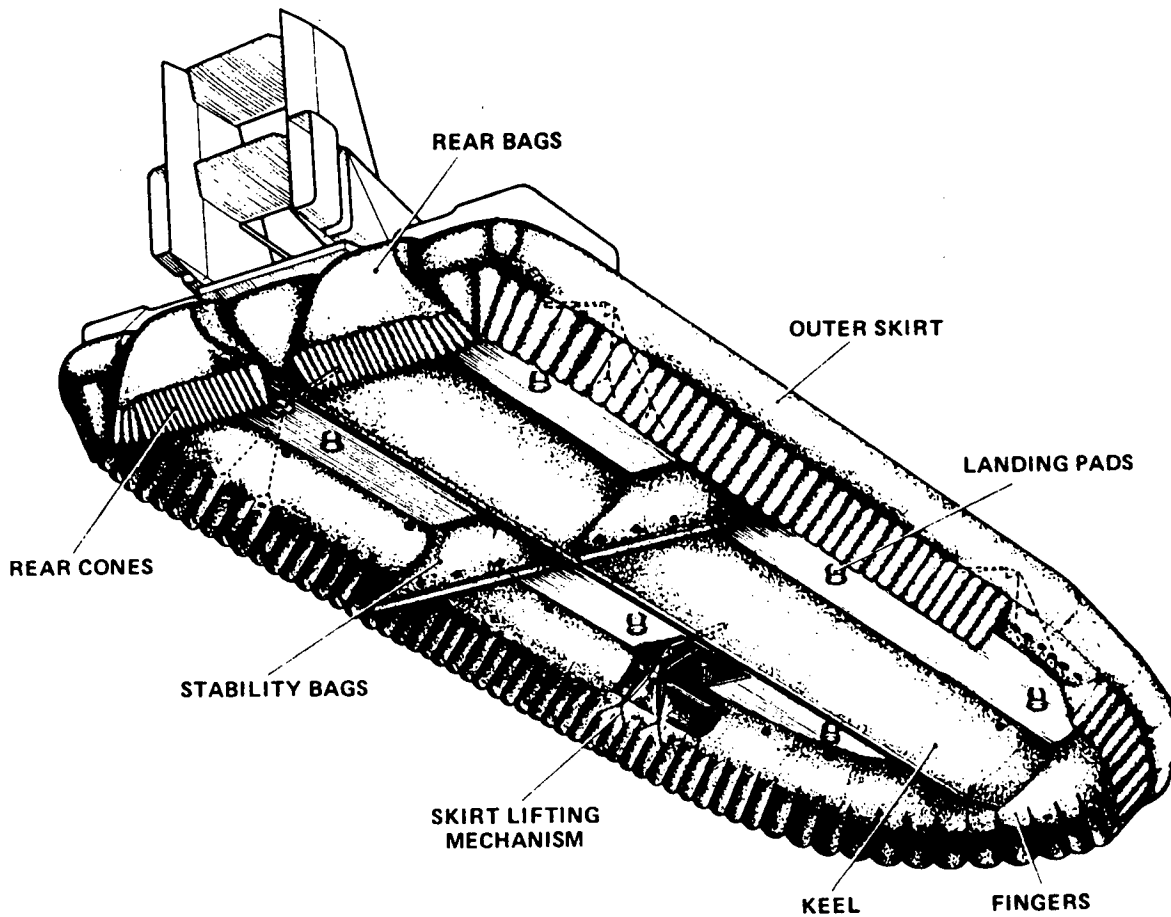

Figure 9. Underside view showing the skirt configuration of an SR.N6

The bow mounting option was selected for this study as representing the most severe test, i.e. if the spray system worked from the bow in an area of maximum potential disturbance (from cushion air and relative airflow), it could likely be made to work in any other installation. The bow installation meets the criteria of introducing the dispersant ahead of any subsequent surface disturbance caused by the jets of cushion air and skirt contact (wetting). The bow installation is the preferred option in the case of calm sea conditions, i.e. it

capitalizes on the potential surface disturbance available from the hovercraft. The disadvantages are a relatively small swath width and a turbulent airflow pattern immediately ahead of the bow.

The spray system was designed to provide a 1:20 application for a 200 μm equivalent slick thickness. Dispersant flow rates were calculated using the formula :

$Q = V W x$ where

Q = pump rate ($\text{m}^3 \text{s}^{-1}$)

V = forward velocity (m s^{-1})

W = swath width (m)

x = dose rate equivalent slick thickness (m)

Nozzle tips were selected to provide a continuous dispersant curtain with a one metre nozzle separation, approximately one metre above the ground. Dispersant volumes and nozzle discharge rates were based on a nominal 100 psi line pressure. Two types of nozzles were used in the trial, UniJet Nozzles Nos. 8006 and 8015 manufactured by Spraying Systems Co. The respective nozzle flow rates at 689 kPa (100 psi) are specified as 4.33 l min^{-1} ($0.95 \text{ gal min}^{-1}$) and 10.9 l min^{-1} (2.4 gal min^{-1}).

Nozzle mounts and a suitable pump were borrowed from the Coast Guard Environmental Emergencies Branch stock of dispersant spray gear. An electrically controlled valve was added to ensure that dispersant would only be sprayed on demand.

Construction and fabrication of the spray boom was kept simple. Aluminum tubing and pipe were bolted together to form a light weight boom. Two 3 m x 38 mm square aluminum tubes were attached to two sets of lift points on the hovercraft foredeck on either side of the centreline. These two tubes projected out and down from the bow to support the actual spray boom

comprising a 32 mm square aluminum tube bolted to a 13 mm aluminum pipe to which the nozzle hangars were attached. The spray pattern was considered symmetrical about the centerline. Consequently, only a half section (port side) was actually fitted with nozzles. Five nozzles were clamped to the 13 mm pipe at a one meter spacing. A wire cable stay was led back from the end of the boom to the hovercraft for additional stiffness. Figures 10 and 11 show the mounted boom assembly.

The boom was positioned 1.3 m ahead of the bow and 0.5 m above the ground with the hovercraft resting on its landing pads. With the hovercraft on full cushion, the boom was elevated approximately 1.4 m above the ground. This was considered the minimum elevation necessary to guard against possible grounding or submergence of the boom extremities during maximum roll or pitch while underway. The spray pattern was tested at this elevation to ensure a continuous overlap on the ground. The pump and dispersant (stored in two 45 L plastic containers) were strapped to the port sidedeck of the hovercraft. (Figure 12). The trigger for the dispersant flow valve was led into the hovercraft cabin.



Figure 10. General view of dispersant spray boom



Figure 11. Close-up view of dispersant spray boom



Figure 12. Dispersant tanks and spray pump

Overland trials with the mounted spray boom took place on August 14, 1986. Three test runs were carried out with the hovercraft discharging 64 L of Corexit 9527 (dyed red with Rhodamine) along a 250 m x 12 m course laid out into the wind on the grass area immediately adjacent to the hovercraft base (Figure 3).

The dispersant spray pattern was measured by operating the spray gear while flying the hovercraft over a continuous strip of Kromekote paper (Figure 13). The Kromekote was taped to plywood panels laid across the flight path at two locations, 80 and 160 m from the spray boom start position. Shallow pans were also fastened to the plywood to collect the dispersant in order to measure the application rate (Figure 14). After each run, the Kromekote cards were photographed, the position on the cards where the centre of the hovercraft passed was marked and the cards then collected, after noting their position relative to the hovercraft's centerline. The dyed-dispersant in the collecting trays was washed, with a colourless solvent, into a sample bottle for subsequent analysis. Unfortunately a large quantity of solvent was required to effectively wash off each tray; this resulted in a very low concentration of dyed dispersant in each sample and made the final analysis unreliable.

Representative Kromekote sheets were selected from each test and the dispersant drop diameters digitized from them. The resulting data was then analysed for dispersant concentration and drop-size distribution. The method used to estimate the original dispersant drop diameters from the Kromekote card stains was adapted from Kristmanson et al. 1981.



Figure 13. View showing the hovercraft approaching test strip



Figure 14. Laying out the Kromekote cards and collection trays across the hovercraft course

Two dry runs were conducted to ensure that the hovercraft could maneuver successfully through the course. A maximum forward speed of 25 knots was attained by the second test panel with the hovercraft proceeding into a headwind gusting to 18 knots. There was no means of providing additional distance for acceleration within the confines of the test area. Downwind runs were not considered practical due to the uncertainty of stopping after the run in the limited distance available.

Three test runs were completed, the first two at 18 to 25 knots forward speed and the last at 14 to 16 knots. At this point, the Coast Guard requested that no further runs be attempted due to ingestion of grass clippings into the turbine filtration system.

RESULTS

SURFACE OIL DISPLACEMENT

Observed Oil Behaviour

In each test, the hovercraft appeared to affect only the oil within its wake. The aerial photography and visual observation indicated that the hovercraft displaced the surface oil in two narrow strips on either side of the central keel, corresponding to the lines of contact of the outer skirt fingers with the water surface (see Figure 9). Surface oil clearly remained in the centre of the track. The visual results of one of the tests can be seen in Figure 15, which illustrates the time history effect on the oil with the hovercraft travelling at 21 knots (Test Run Number 5 - see Table 2). The red Canola oil is still visible in the hovercraft wake after passage. Similar results were obtained on all of the runs regardless of speed or hovercraft trim.

Surface Oil and Water Samples

Summaries of the surface oil thickness measurements taken before and after each pass of the hovercraft are presented in Table 2. These results indicate that, by the time surface samples were taken after the passage of the hovercraft (within 30 to 60 seconds), any oil that had been temporarily displaced by the hovercraft returned to a similar distribution on the surface. The overall average slick thicknesses for all runs shown in Table 2 indicate a possible slight reduction in the surface oil quantity immediately after passage of the hovercraft. Figure 16 shows a view over the side of the sampling boat immediately following passage showing the dispersed oil particles surfacing in the hovercraft track. Within a few minutes after passage the Canola oil appeared to consolidate back into a patchy slick similar to that existing prior to the hovercraft's arrival.

Approaching Slick



Past Slick

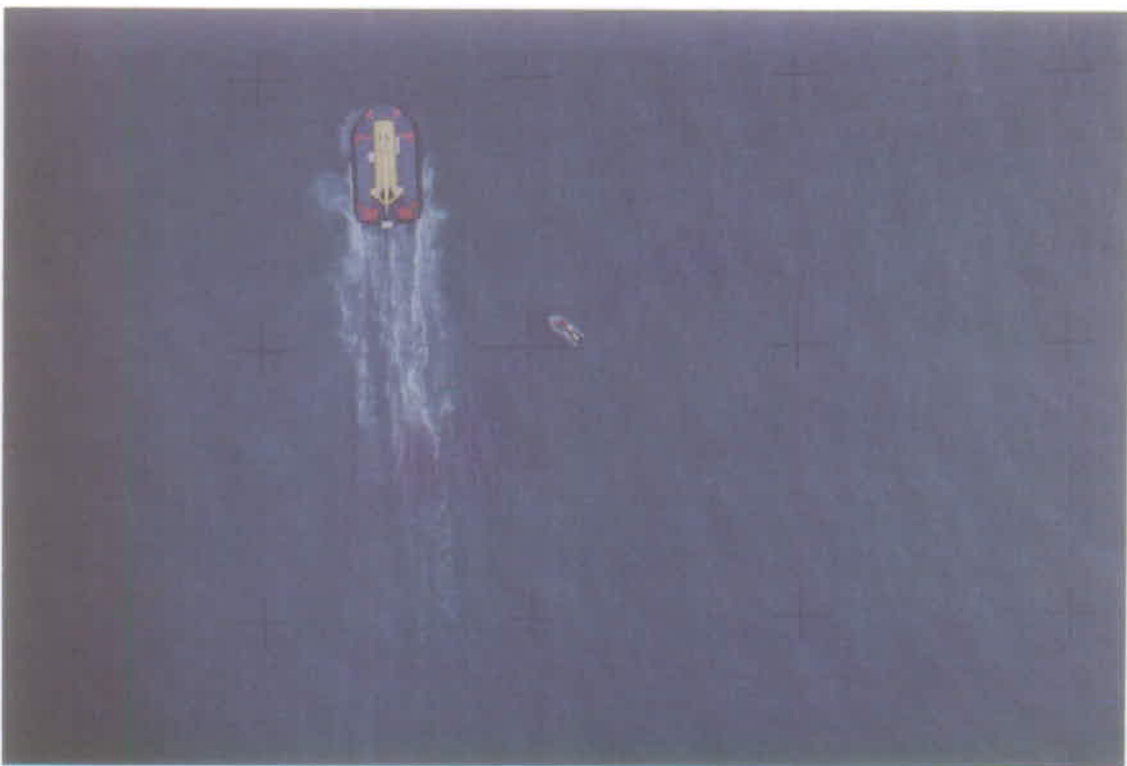

Figure 15. Two views showing the hovercraft proceeding at 21 knots through a dyed Canola oil slick (Run No. 5)



Figure 16. View over the side of the sample boat immediately following hovercraft passage.

Oil-in-water concentrations measured before and after the passage of the hovercraft are also recorded in Table 2. A statistical analysis of this data indicates that little oil was likely to be permanently dispersed by the the hovercraft mixing energy alone. The comparison of mean oil thickness measured before and after passage of the hovercraft (Table 2) does not show a significant difference in the quantity of surface oil present after passage of the hovercraft. However, large oil drops were observed in the water column immediately after the passage of the hovercraft indicating that some mixing did occur. These observations suggest that the effect of the hovercraft on a slick which has been recently treated with dispersants might be significant, due to the reduced oil-water interfacial tension

(inferring that dispersion is caused by the hovercraft passage). At the 95% confidence level there is no statistical difference in oil thickness before or after passage.

MIXING ENERGY

Analytical Approach

For proper profiling, measurement of the depth of the sample is as important as that of the concentration especially when working only in the top one meter of the water column. Slight errors in depth are to be expected and small scale dislocations in the profiles cannot be taken as significant. Too few runs were taken for averaging or for calculation of significant statistics. The dye tests were only intended to provide relative results.

The distribution of the dye may become patchy. As a result, absolute concentration levels can vary greatly between profiles. If one assumes that the governing processes are the same between profiles, a proper scaling of the concentrations will help to illustrate their effects.

Both vertical and horizontal mixing occur in the environment. The time scale for the vertical mixing energy is very short relative to the natural horizontal mixing. In this experiment, the mechanical mixing generated by the hovercraft or breaker board, will be considered as an almost instantaneous vertical mixing event. After the event, the resulting profiles can be considered to be governed primarily by horizontal diffusion.

The mechanical mixing process examined was not a time dependent diffusion process but must be considered as an "event". As such, standard diffusion equations and parameterizations cannot be used to describe the results. Parameterization of "events"

can only be performed if numerous "events" occur and the results averaged. This is the basis for the calculation of, for example, shear dispersion coefficients. In an "event" situation, it is also very difficult to separate active from fossil turbulence when measuring passive scalars (such as dye concentration). Fossil turbulence results when the diffusion time scale for the scalar is much longer than that for the introduction of the energy. Even if one has taken numerous concentration profiles after an "event", there is no way to assure that vertical mixing is occurring at full strength, and more likely, it is either decaying to background levels or horizontal diffusion is dominating the mixing process.

In order to reduce variability due to patchiness, and emphasize the vertical distribution of a profile, the data were scaled. To scale a profile, the concentration or mean concentration at each depth was assumed to occupy an equivalent volume. The total dye present is taken as the sum of all concentrations, and the scaled value is determined as the fraction of total dye in that depth bin. This scaling assumes that all dye in a vertical profile originated at the surface of that profile.

Control Profiles

Three profiles of control dye patches were made, one from the hovercraft test and two from the breaker board test. The results are listed in Table 3 and shown in Figure 17, with both absolute and relative (scaled) dye concentrations shown.

All controls show little or no dye measured at a depth greater than 0.5 meters over the experiment. The two control profiles from the breaker board test, BBC 15:40 and BBC 16:00 show a drop in dye concentration with time, possibly indicating that horizontal diffusion is occurring.

HOVERCRAFT DISPERSION EXPERIMENT

HOVERCRAFT DISPERSION EXPERIMENT

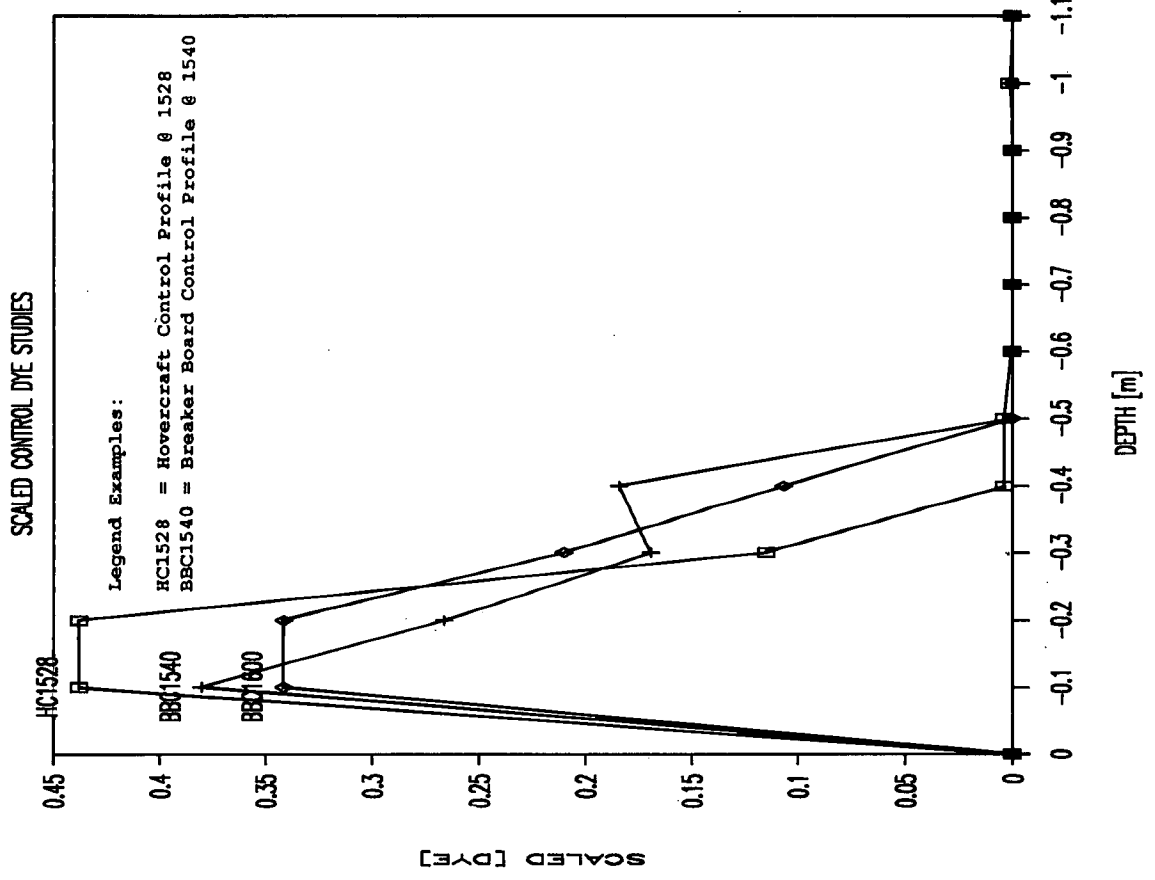
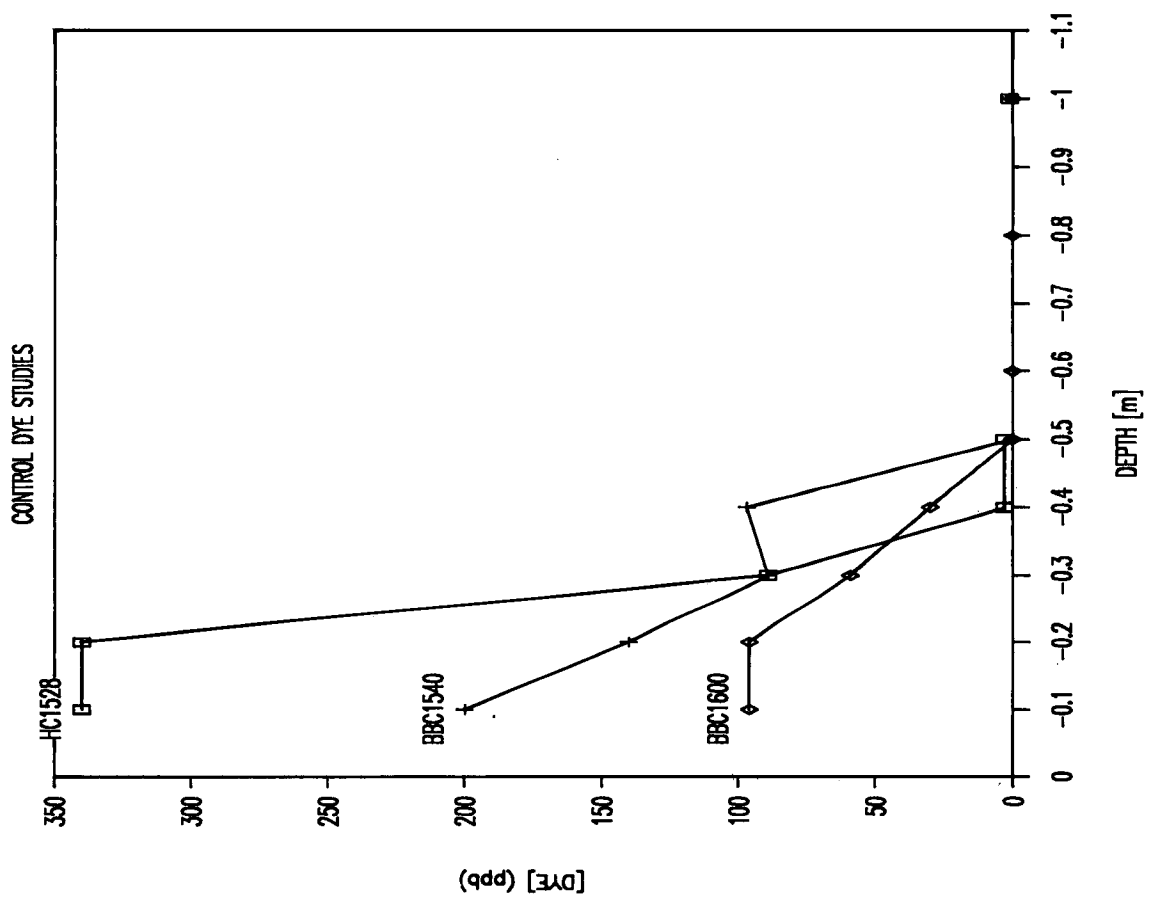

Figure 17. Profiles of control dye patches

Experimental Profiles

The hovercraft results (Table 3, Figure 18a) indicate large variations between profiles in the horizontal and in the vertical (eg. an apparent submergence of the dye at H 15:20), perhaps as a result of patchiness. Similar patterns are observed for the breaker board experiment (Figure 18b), although smoothing of the profiles for the breaker board experiment may indicate more vertical mixing.

Figure 19 presents the scaled concentration profiles. It is apparent from these figures that the breaker board induced more vertical mixing, as indicated by the tilting of the profiles toward a more uniform distribution with depth, than did the hovercraft. These conclusions must be considered as tentative in view of the limited number of profiles. However, it did appear that the hovercraft acted to split-up the dye patch as opposed to mixing the dye into the water column, the case for the breaker board. In order to calculate any statistics, or to parametrize the mixing process observed, numerous repetitions of the experiment as well as additional profiles per experiment would have to be performed. Parameterization may be important if this method of induced vertical mixing needs to be modeled at some future date.

TABLE 3. MEASURED DYE CONCENTRATION (ppb)

Control Tests

Depth (m)	Hovercraft	Breaker Board	
	HC 15:28	BBC 15:40	BBC 16:00
surface			
0.10	340	200	96
0.20	340	140	96
0.30	89	89	59
0.40	3	97	30
0.50	1.50	0	0
0.60	0	0	0
0.80	0	0	0
1.00	1	0	0

Experimental Hovercraft Tests

Depth (m)	H 15:20	H 15:25	H 15:30
surface			
0.10	0	0	7
0.20	0	510	9
0.30	0	44	0
0.40	270	89	1
0.50	310	0	0
0.60	240	0	0
0.70	21	0	-
0.80	0	0	4
1.00	0	0	3

Experimental Breaker Board Tests

Depth (m)	BB 15:50	BB 15:55	BB 15:58
surface			
0.10	0	33	-
0.20	0	42	33
0.30	74	23	38
0.40	96	3	10
0.50	67	45	6
0.60	50	-	4
0.80	25	-	14
1.00	0	-	2

HOVERCRAFT DISPERSION EXPERIMENT

HOVERCRAFT DYE STUDIES

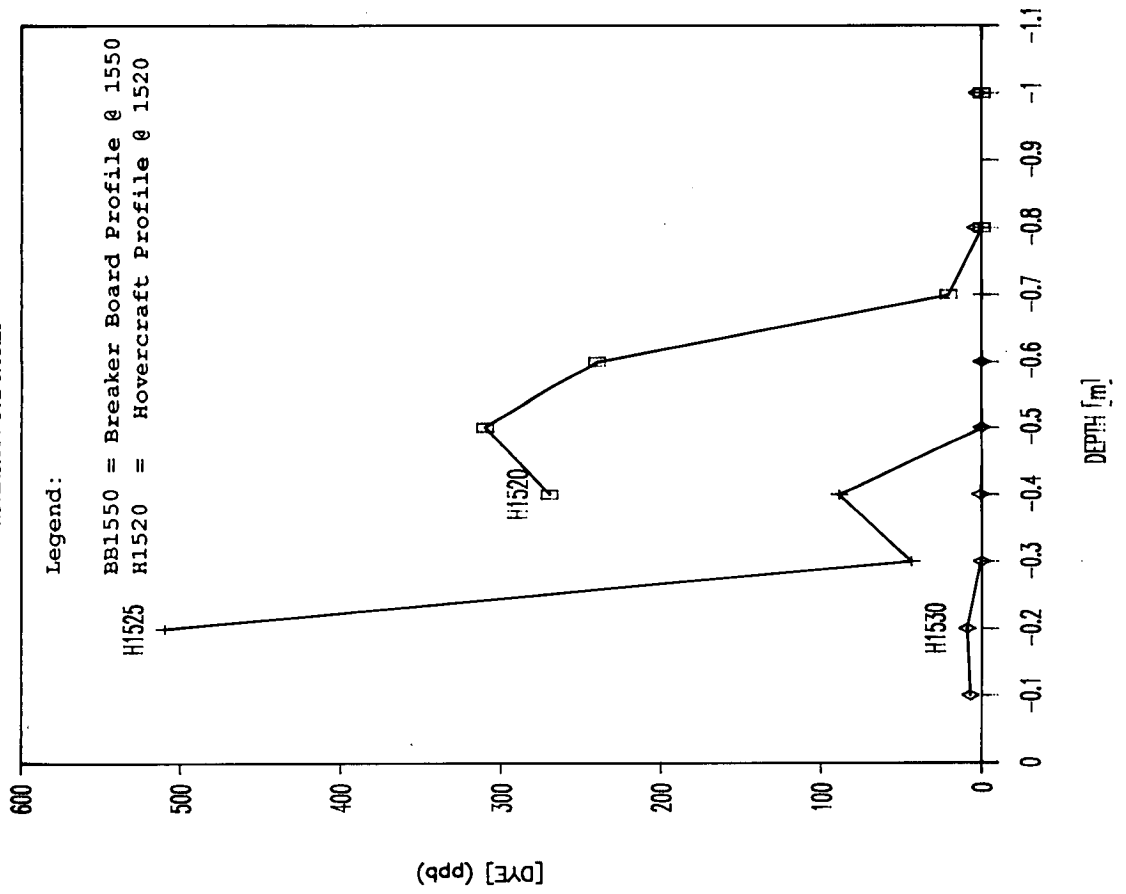

HOVERCRAFT DISPERSION EXPERIMENT

BREAKER-BOARD DYE STUDIES

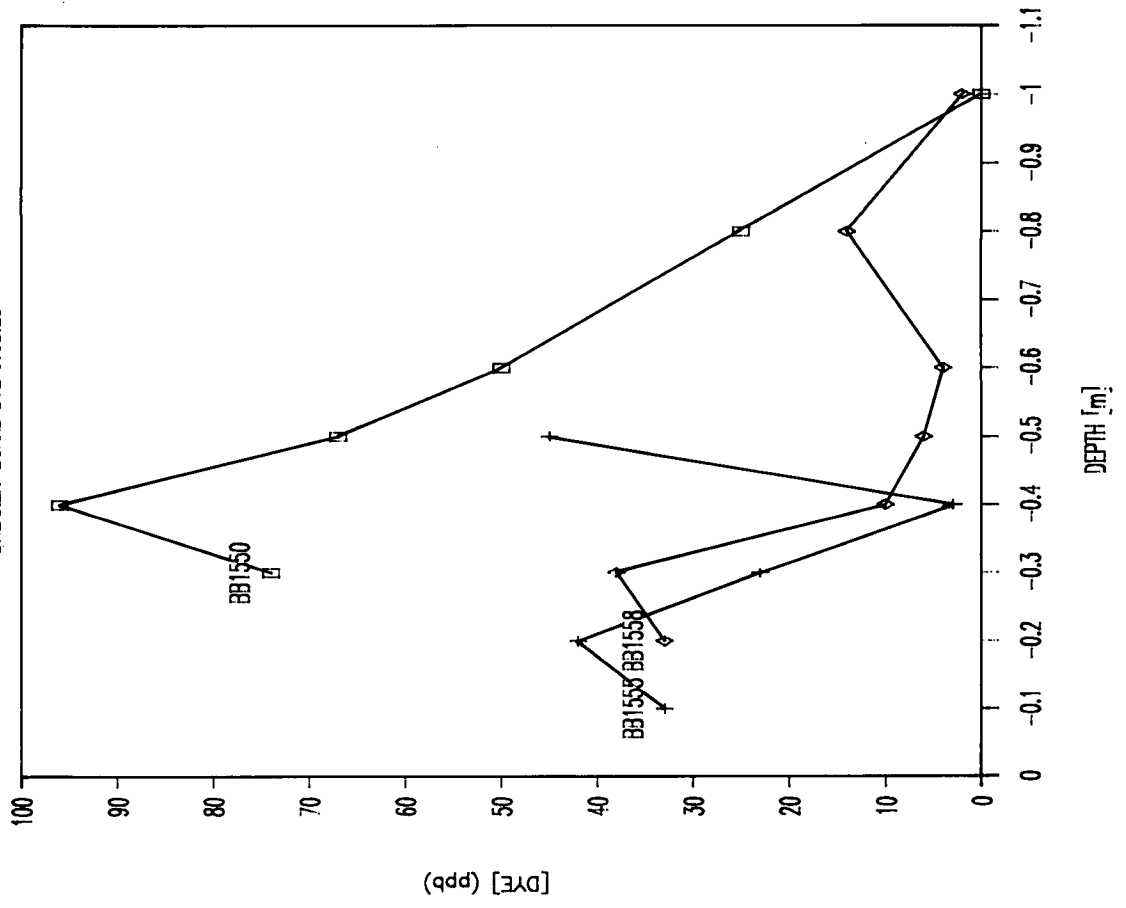
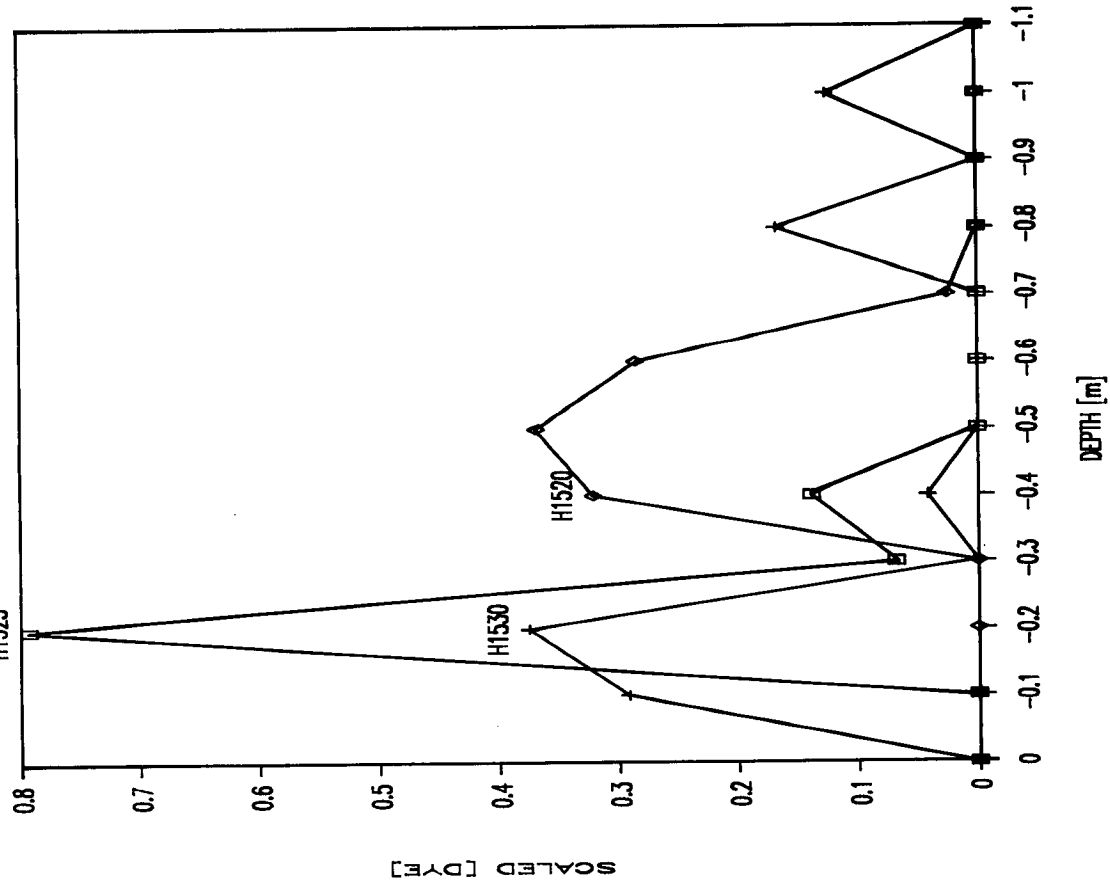

Figure 18. Dye profiles

HOVERCRAFT DISPERSION EXPERIMENT

SCALED HOVERCRAFT DYE STUDIES



HOVERCRAFT DISPERSION EXPERIMENT

SCALED BREAKER-BOARD DYE STUDIES

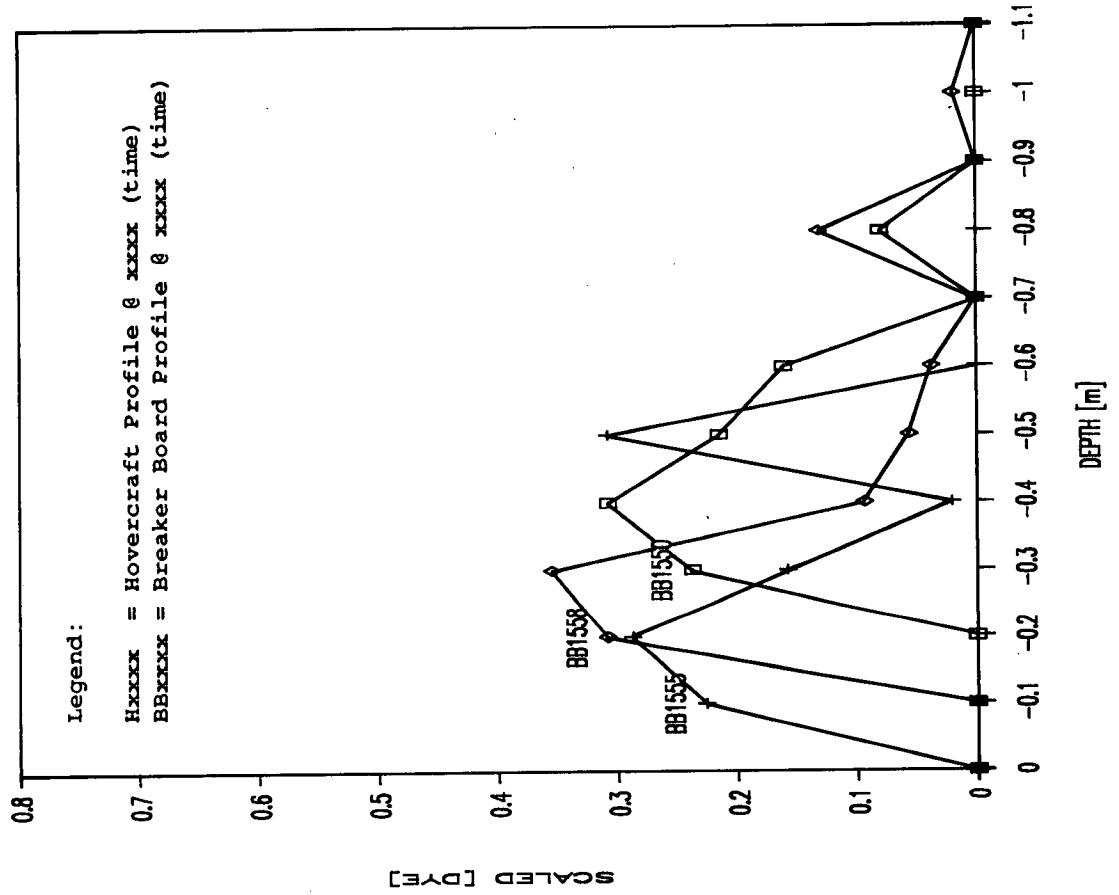

Figure 19. Scaled dye profiles

DISPERSANT SPRAY PATTERN

Drop Size Distribution

Table 4 shows an example of the dispersant drop size analysis from Kromekote cards. The volume median drop diameters (VMD) reported in these analyses have been plotted vs. position from the hovercraft centerline for each run (Figure 20).

The Kromekote cards were calibrated according to methods presented in Kristmanson et al., 1981. The sample size of 96 drops shown in this example is considered sufficient to carry out basic averaging and to develop a drop size distribution. The manual methods used in this study limited the available sample size, but offered an advantage over automated systems in that every drop recorded was known to be dispersant. Recent work carried out by SL Ross in conjunction with the National Research Council of Canada has confirmed the validity of relating the Kromekote stain to the original drop volume.

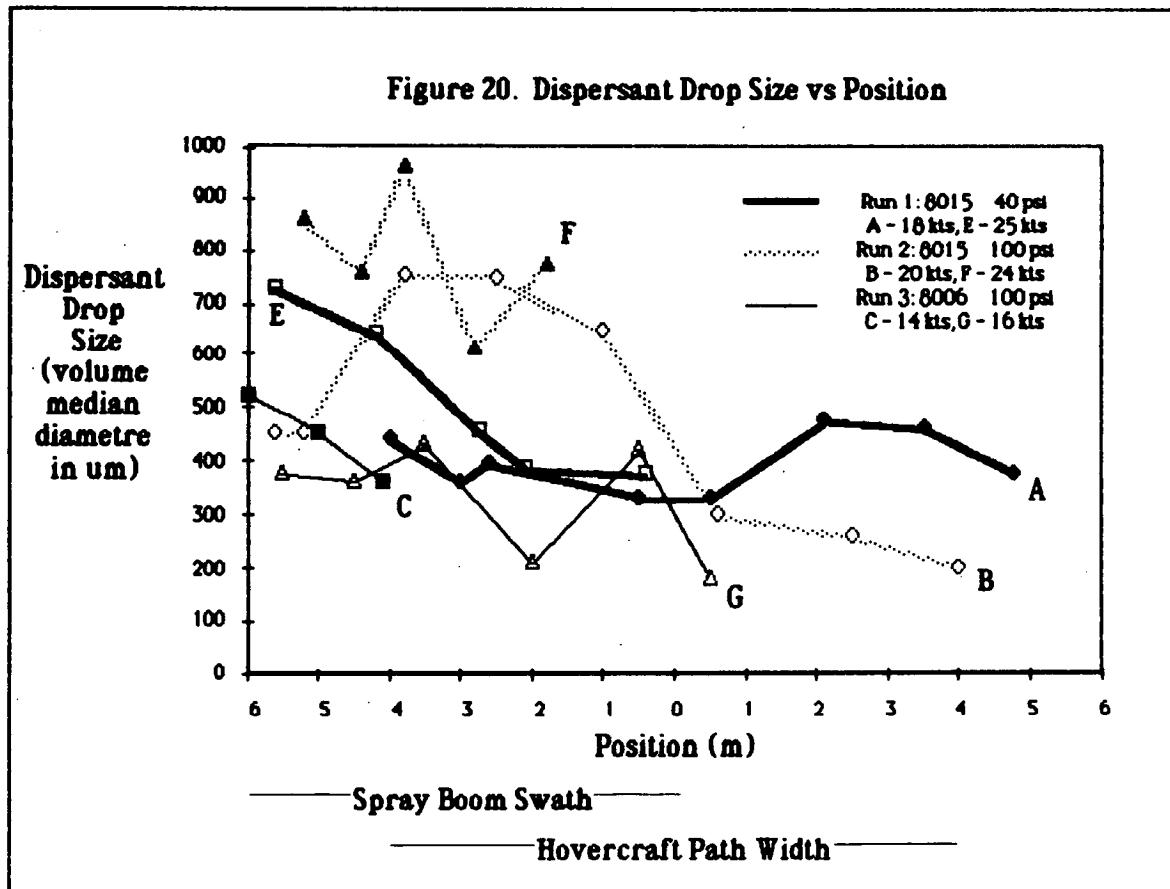

Table 4. EXAMPLE DISPERSANT DROP SIZE ANALYSIS
(Size in Micrometers)

Maximum Drop Size: 545.3 μm
 Minimum Drop Size: 35.9 μm
 Average Drop Size: 180.9 μm
 Volume Median Diameter (Vmd): 399.3 μm

Oil Drop Size Distributions

Range	# of Drops	% of Drops	% Less Than	Vol %	% Vol Less
0. - 50.	3	3.1	3.1	.01	.01
50. - 100.	16	16.7	19.8	.46	.47
100. - 150.	37	38.5	58.3	5.98	6.45
150. - 200.	8	8.3	66.7	3.38	9.82
200. - 250.	11	11.5	78.1	8.41	18.24
250. - 300.	8	8.3	86.5	12.51	30.75
300. - 350.	0	.0	86.5	.00	30.75
350. - 400.	5	5.2	91.7	20.00	50.75
400. - 450.	7	7.3	99.0	37.33	88.08
450. - 500.	0	.0	99.0	.00	88.08
500. - 550.	1	1.0	100.0	11.92	100.00

TOTAL # DROPS 96 TOTAL DISPERSANT VOLUME (ML) = .00071239

NUMBER OF DROPS REJECTED FROM DIST. = 0

The general trend indicated by the drop size data is an increasing drop size when moving out from the centerline of the hovercraft. The larger spray nozzle (8015) produced larger drops on average than did the smaller 8006 nozzles, as would be expected. However, the large nozzles appear to have produced smaller drops when operated at a lower pressure, contrary to their theoretical operation. This may simply be due to the small quantity of dispersant which reached the target area due to the lower flow rate when these nozzles were operated at the low pressure (see section on dispersant dosage). This may also explain the smaller drop sizes at the 5 and 6 metre positions of Run #2 -B. The boom was turned on late in this test, which would have led to low flows at the outer nozzles on the spray boom as it passed over the first target zone.

The results from the more reliable Runs #2 and #3 indicate that the 8015 nozzle generated drops in the 600 to 950 μm range (VMD) and that the 8006 produced drops in the 300 to 450 μm (VMD) range. Figure 21 shows a sample portion of the second Kromekote test strip from Run 2 (line F plotted in Figures 20 and 22); drop sizes are in the range of 600 to 1000 μm . These results compare favourably with the dispersant drop sizes measured from large fixed wing aerial application during the Suffield Dispersant trials (Kristmanson et al. 1981) where 25 to 50% of the dispersant was found in drops between 200 to 700 microns in diameter. The Rotortech TC3 underslung spray bucket for helicopter application has been reported to generate somewhat larger dispersant drops (VMD of approximately 900 μm) (Martinelli 1981).

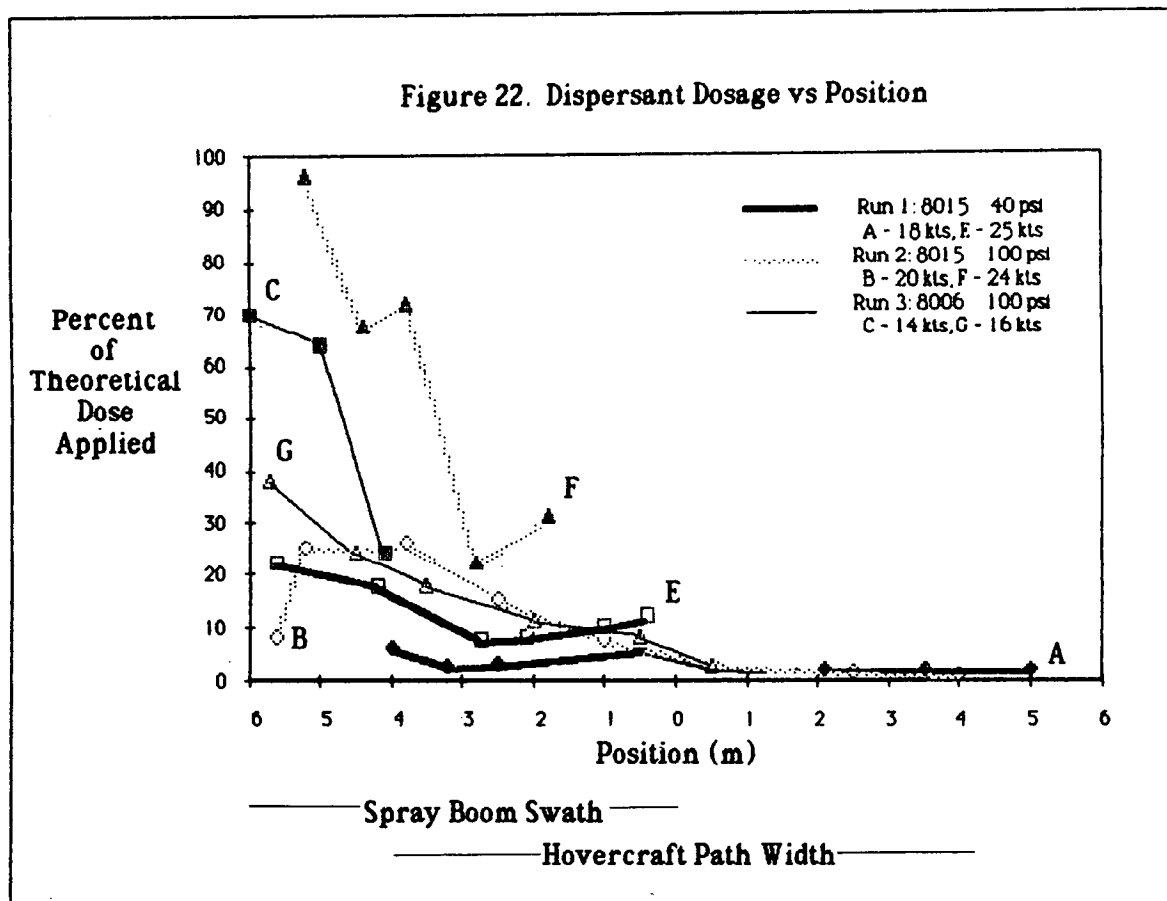

Figure 21. Example dispersant spray pattern

Dosage

An estimate of the dispersant dosage hitting the Kromekote card target has been made by summing up the volume of each of the dispersant drops digitized in a known area on each card. The total volume of dispersant in the digitized drops is reported at the bottom of each drop-size distribution analysis (see Table 4). These calculated dosages have been plotted as a percentage of the theoretical maximum dosage (determined by calculating the flow rates from the nozzles at the operating pressure during the test) vs. distance from the hovercraft centerline (see Figure

22). The general trend indicated by the data is one of increasing dosage when moving out from the centerline of the hovercraft. Dispersant from the centerline nozzles was observed moving up and over the air slip-stream of the hovercraft during the trial thus accounting for the reduced dosage in the centre of the swath. The poor dosages in Run #1, A and E targets, are possibly due to the lower pressure during this run causing a slower exit velocity of the dispersant and making it more susceptible to wind drift. The low dosages at the 5 and 6 metre positions on Run #2, target B are likely a result of the late start of the spray gear during this run and thus poor flow at the outboard nozzle.



With the exception of the target B results, the higher pressure tests resulted in the best dosage results. There is also some indication (target F) that the larger nozzle opening and thus larger drop size results in an improved dose rate. Further study would be necessary to determine the optimal dispersant drop size when considering the two factors of improved drop density with smaller dispersant sprays, and improved overall dosage with larger dispersant drops. Recommendations for reducing the relative airflow over the spray boom and moving the boom closer to the surface while underway are expected to provide an even dose rate across the entire swath width.

DISCUSSION

The study showed that hovercraft should be considered as fast response vehicles for applying dispersants. The hovercraft's speed, amphibious capability and ability to operate under conditions of poor visibility provide a unique combination of operational advantages which is unequalled by either displacement vessels or aircraft.

Results of the field trials carried out in this study are summarized and discussed below relative to the original hypotheses which formed the study objectives.

1. A hovercraft can be operated through an oil slick at speeds greater than 15 knots without causing lateral displacement of the slick or significant dispersion of the oil into the water column. Local submergence related to drag of the outer skirt fingers was minimal and considered short lived in the absence of dispersants.
2. A hovercraft does not impart vertical mixing energy into the water column to the same degree as that obtained with a traditional breaker board. Hovercraft may assist the dispersion process within a narrow strip under calm sea conditions encountered in protected waters. However, under more typical offshore conditions the continuous natural mixing energy available through wave action will far exceed the short lived local surface disturbance added by the hovercraft. In this case, it would make little sense to limit the swath width to the hovercraft beam; 5 m outrigger booms on either side will more than double the effective swath width and result in greatly enhanced application efficiency.

3. The dispersant sprayed out ahead of the hovercraft in this experiment was affected by the high relative airflow on the day of the test, the result of having insufficient maneuvering room to operate downwind. In a practical operational setting, the application direction and forward speed can be arranged to minimize the relative airflow. Appropriate operating techniques in combination with a retractable boom assembly to allow spraying closer to the sea surface, will provide a uniform dosage rate and drop size across the entire swath width.

The overland spray test is considered representative of an offshore trial with the exception that the available test track did not offer the option of operating at angles to the wind. Concern has been expressed that water spray generation across the bow may interfere with the dispersant drops reaching the surface in a practical application. This potential problem is not a factor because hovercraft typically operate at a slight bow-up trim angle to ensure that the bow skirt material is not in continuous contact with the water surface. Also, the air jet escaping from the the cushion at the bow is cancelled by the relative craft motion at typical operating speeds exceeding 20 knots. The end result is that the water surface immediately surrounding the bow of a hovercraft underway remains relatively undisturbed with little evidence of any spray generation.

The concern was raised that the hovercraft cushion air escaping from underneath the bow fingers was interfering with the spray pattern and contributing to the uneven dose rate. This concern was addressed by making a series of measurements ahead of the bow with the hovercraft tethered into wind on full cushion (maximum air escape). These results showed that the influence of the cushion air was

localized to a thin jet immediately at the surface. This jet started out at 15 m/sec within 50 cm of the bow skirt and quickly reduced to less than 7 cm/sec at a 2 m distance. At 40 cm elevation there was no measureable influence of the cushion jet at any location; the airflow at this height was 2 to 5 m/sec into the bow, corresponding to the wind at the time. A spray boom mounted 2 m ahead of the bow, and with the facility to be lowered as close to the water surface as conditions allow, will ensure that most of the dispersant contacts the surface rather than being blown back over the hovercraft. During trials with the Bell Voyageur in 1977 (Gill, 1978), it was shown that the spray pattern from side mounted booms was not adversely affected by cushion air escaping along the side of the hovercraft.

In spite of the promising results shown by these earlier trials, recognized authorities continue to disregard hovercraft (Warren Spring Laboratory, Pers. Comm. July 1986 - See Appendix A).

RECOMMENDATIONS

Based on experiences with this study, the development of an effective dispersant application system for operation from a hovercraft appears feasible. The principal advantages of a hovercraft over conventional surface vessels are its high speed and amphibious capability. Compared with helicopters, hovercraft can carry larger dispersant payloads and operate under extreme low visibility conditions. In the arctic, the hovercraft's amphibious capability provides significant advantages over any other form of surface transportation.

The following are suggested as the minimum equipment requirements for fitting to a hovercraft of opportunity in the event of a spill.

1. Gas driven pump adapted to the exposed marine environment of the hovercraft sidedeck, i.e. splash protection. Suitable tie down points with quick disconnects will facilitate rapid response. Ideally the pump should have provision for electric start from within the cabin together with a suitable cabin mounted pressure gauge. The pump discharge valve should also be electrically operated from within the cabin. Pump sizing will depend on the practical operating speed of the hovercraft, oil slick thickness and boom width.
2. Dispersant containers should be available with fittings for rapid pump connection and attachment to the hovercraft. A level gauge or float should be clearly visible from within the cabin.
3. Separate spray booms should be available for easy pin connection to 1. the bow cleats and lift points, and 2. the side decks (as wire stayed outriggers). All of the booms should be capable of being lowered to operate as close to the surface as sea conditions permit (down to about 50 cm), and being retracted prior to landing on a hard surface.

In order to minimize the relative airflow effects, it is recommended that the hovercraft apply dispersant with the wind wherever possible. The following guidelines are derived from the Canadian Coast Guard hovercraft operations manual, and reflect the personal opinions of the flight crews who participated in this experiment.

Table 5. Recommended Guide to Downwind Dispersant Application Speeds

Wind Strength Tailwind (knots)	Practical Minimum Craft Speed (knots)
< 15	15
15 to 30	20 to 30
> 30	Beyond control limits

Clearly as the wind reduces to a calm or light breeze, the direction of application becomes less important. At this point the aim should be to operate at the minimum comfortable speed while staying above the speed of maximum drag and wavemaking (so called hump speed); this means operating at 15 knots or greater. Table 5 only applies to the SR.N6. Other types of hovercraft may be more or less sensitive to weathercocking in a tailwind situation and will have different speed limitations.

In order to demonstrate the practical utility of hovercraft as dispersant applicators in a spill situation, the following estimates were made as to the potential coverage areas which are possible with the two principal types of hovercraft currently operated by the Canadian Coast Guard, the SR.N6 in Vancouver and the AP.1-88 in Montreal. Specifications for these two hovercraft types together with the Wartsila Larus currently based in Tuktoyaktuk, are shown in Appendix B. It should be noted that in the event of a spill in the arctic, the SR.N6 is capable of being broken down for transport in a Canadian Armed Forces Hercules.

**Table 6. REPRESENTATIVE DISPERSANT TREATMENT
CAPABILITIES OF DIFFERENT HOVERCRAFT**

	AP.1-88	SR.N6
Deckload (Tonnes)	10.0	2.7
Swath Width (m)	18.6	17.2 *
Assumed Average Speed (kts)	25.0	25.0
Pump Rate (L/sec)	2.32	2.15 **
Available Spray Time (min)	77.0	22.0
Max Coverage Area (km ²)	1.1	0.29

* with 5 m outrigger booms

** based on a 10 μ m equivalent slick thickness of dose rate (associated with a 200 μ m oil slick at a 20:1 oil/dispersant ratio)

REFERENCES

- Allen, A. and W.G. Nelson. 1983. Canola oil as a substitute for crude oil in cold water spill tests. in Proceedings, 6th Arctic Marine Oil Spill Program Technical Seminar, Edmonton.
- Belore, R.C. 1986. Development of a high-pressure water mixing concept for use with ship-based dispersant application. Environmental Studies Revolving Funds Report No. 034. Ottawa. p.50.
- Belore, R.C. 1987. Mid-scale testing of dispersant effectiveness. Environmental Studies Revolving Funds Report No. 068. Ottawa. p.82.
- Belore, R.C. 1982. A device for measuring oil slick thickness. Spill Technology Newsletter. Environment Canada. Vol 7(2), March - April.
- Fingas, M. 1986. The effectiveness of oil spill dispersants. Environmental Emergencies Technology Division, Environment Canada, Ottawa.
- Gill, S.D. 1978. Dispersant field trials in Canadian waters - Use of hovercraft as a dispersant spraying platform. in Chemical Dispersants for the Control of Oil Spills, ASTM STP 659, pp 159-168.
- IMO/UNEP. 1982. IMO/UNEP Guidelines on oil spill dispersant application and environmental considerations. International Maritime Organization/United Nations Environment Programme.
- Kristmanson, D.P., J.J.C. Picot and J.B. Smedley. 1981. Suffield aerially applied dispersant overland field trials. Prepared for the Offshore Dispersant Field Trial Task Force.
- Lindblom, G.P. and G.D. Barker. 1979. Evaluation of equipment for aerial spraying of oil dispersant chemicals. Special Technical Publication 659. American Society for Testing and Materials. p.169-179.
- Lindblom, G.P. and B.S. Cashion. 1983. Operational considerations for optimum deposition efficiency in aerial application of dispersants. Proceedings of the 1983 Oil Spill Conference. American Petroleum Institute, Washington, D.C. p.53-60.
- Mackay, D., J.C. Picot and D.D. Kristmanson. 1980. Theoretical assessment and design study of the aerial application of oil

spill dispersants. Report prepared for the Petroleum Association for Conservation of the Canadian Environment and Environment Canada.

Martinelli, F.N. 1981. Dispersant spraying equipment: the Rotortech TC3 underslung spray bucket. Warren Spring Laboratory, Department of Industry, Stevenage, Hertfordshire.

Meikle, K.M. 1978. Air cushion vehicles and oil spill clean-up operations. Spill Technology Newsletter, Nov-Dec, Ottawa.

Smith, J.W. and F. Shuttleworth. 1969. Development of the W.S.L. dispersant spraying equipment. Warren Spring Laboratory report for Department of Trade and Industry.

Appendix A

Literature Search Results & Related Patent Descriptions



Department of Trade and Industry

Warren Spring Laboratory

Gunnels Wood Road Stevenage Hertfordshire SG1 2BX
Telex 82250 Telephone Stevenage 313388 Facsimile 60858

Anthony Dickinson
D F Dickins Associated Limited
3732 West Broadway
Vancouver, B.C.
Canada
V6R 2C1

Your reference

Our reference 133/9/4

Date 11 July 1986

Dear Mr Dickinson

Thank you for your letter to Dr Martinelli received here on 7 July.
Dr Martinelli no longer works for Warren Spring, and now acts as a Consultant to Dasic International Limited, Winchester Road, Romsey, Hampshire, SO5 8YD, telephone no. Romsey (0794) 512419 where he can be contacted.

I know of no studies in the UK on the use of hovercraft to spray dispersant. The reasons for this are that we have always considered aircraft and boats as being the most suited operational platforms for dispersant application. Hovercraft tend to be large passenger craft used entirely for regular ferry operations and seldom available for other work.

Apart from the logistical limitations their non-availability may pose, technically they are unlikely to be of any use. This is because they generate a considerable airflow in the region of the hovercraft which will almost certainly herd any oil well away from the immediate vicinity of the vessel. Apart from the oil herding problem they generate a considerable amount of spray and anyone within about 10 metres of a hovercraft will be aware of the extent of this spray problem. This means that any concentrated dispersant applied undiluted will almost be lost to the spray and fall on any oil which had not been blown well away in the form of a dilute solution.

All in all we have never considered hovercraft as suitable operational systems and this may account for the lack of published information on their use in the role of a dispersant spraying system.

Yours sincerely

P R MORRIS
Head, Oil Pollution Division

P.S. I am sending a copy of your original letter and my reply direct to Dr Martinelli.

0496110 6907009

C/ APPLICATION OF CHEMICAL SUBSTANCES OVER LARGE AREAS

Inventors: RANDALL DACID CORBET; SORAPURE VICTOR EDGAR

Assignee Names: UNASSIGNED OR ASSIGNED TO INDIVIDUAL Assignee Codes: 68000

Patent No.: 3439875 (Cited in 005 later patents)

Issue Date: 690422 Pub Year: 1969 Document Type: UTILITY

Claim:

D R A W I N G

A METHOD AND APPARATUS FOR DISPERSAL OF UNDESIRABLE FLOATING OIL ACCUMULATIONS ON A WATER SURFACE BY APPLICATION OF AN EMULSIFYING AGENT INTO THE AIR STREAM OF AN AIR CUSHION VEHICLE AND DIRECTING SAME IN A MANNER CREATING TURBULENT CONDITION AND ATTACKING BOTH UPPER AND UNDER SURFACES OF THE FLOATING OIL. AN AIR CUSHION VEHICLE IS PROVIDED HAVING SKIRT MEANS AT THE PERIPHERY THEREOF, SAID SKIRT MEANS FORMED AS A PAIR OF DEPENDING SKIRT MEMBERS SPACED APART TO DEFINE A PERIPHERAL DUCT TERMINATING IN A JET NOZZLE, FAN MEANS TO FORCE AIR INTO SAID DUCT AND FROM SAID JET NOZZLE AND SPRAY MEANS FOR DISPENSING AN EMULSIFYING AGENT FROM A SOURCE THEREOF CARRIED BY THE VEHICLE TO THE VICINITY OF THE JET NOZZLES

13/3/1
436248

Controlled droplet application via hovercraft is the spraying method chosen at the Centre for Overseas Pest Research (Porton Down, England) for applying pesticides to crops on land too wet for wheeled vehicles.

#New Scientist June 15, 1978 p. 754

Controlling oil pollution using double swirl chamber nozzles - supplied with oil-dispersant compsn. and supported on booms

Patent Assignee: (DELV) DELAVAN LTD; (PERC/) PERCIVAL D R

Author (inventor): PERCIVAL D R; SHELDON W

Patent Family:

CC Number	Kind	Date	Week
WO 8102693	A	811001	8141 (Basic)
NO 8103889	A	820118	8206
EP 47758	A	820324	8213
DK 8105105	A	820419	8219
JP 57500618	W	820408	8220
DE 3162731	G	840426	8418
EP 47758	B	840321	8413

Priority Data (CC,No,Date): GB 809486 (800320)

Applications (CC,No,Date): EP 81900643 (810319)

Abstract (Basic): Appts. for combatting water-borne oil pollution comprises a boom mounting double swirl chamber nozzles each having a primary swirl chamber with a tangential inlet and an outlet orifice connected to a secondary swirl chamber. The chambers and their outlet orifices are coaxial. A pump delivers oil-dispersant compsn. to the nozzles under pressure.

The nozzles may be mounted on a water-borne vehicle, e.g. a tug or lighter transversing the polluted region, or on an air-borne vehicle, e.g. hovercraft, helicopter or aircraft. The mean droplet size is about ten times that of the mean droplet size of a conventional nozzle and is pref. 1000 to 1500 microns. Because the droplets are larger, the spray is less susceptible to drift. The nozzles can be mounted higher from the water so as to cover a greater band width of polluted water.

(20pp)

18/9/2

018647 WPI Acc No: 81-B7661D/09

Manure or fertiliser spreading machine - comprises hovercraft with hopper or tank and spray nozzles or spreading blade extending from one end

Patent Assignee: (BUI/) BOITARD M

Patent Family:

CC Number	Kind	Date	Week
FR 2455849	A	810109	8109 (Basic)

Priority Data (CC,No,Date): FR 7911699 (790509)

Abstract (Basic): The agricultural machine is for spreading manure, fertilisers etc, and consists of a hovercraft (1) with a hopper or tank (8,7) for the manure and a spreading mechanism. The tank can accommodate liquid manure, and spreading can be by spray nozzles working in conjunction with a blade (9).

Alternatively, the hopper can accommodate fertiliser in powder or granular form. The blade can be at the rear, and there can be a guard flap (12) between it and the machine.

Appendix B

Existing Hovercraft Specifications

AP.1-88 LOGISTIC SUPPORT CRAFT - ARCTIC VARIANT

R.L. Wheeler
British Hovercraft Corporation
East Cowes, I.W., U.K.

SUMMARY

The AP.1-88 diesel-powered hovercraft has achieved a major step towards the production of a cheap, quieter and commercially viable amphibious hovercraft. Power requirements have been significantly reduced as a result of the application of new skirt technology, stemming from the development of the low pressure ratio, deep fingered skirt of the late 1970s and exploited on the two Hoverspeed SR.N4 Mk.3s. With respect to these craft, the all-up-weight was increased from 200 tons to 300 tons in stretching from the Mk.2 to the Mk.3 configuration with only a small increase in power. The overall hp/ton was in fact reduced by 25%. With the AP.1-88, these advantages were incorporated in a different manner in that the increase in payload potential was traded towards the use of heavier, but considerably cheaper diesel engine units and craft structure.

The AP.1-88 was introduced in pre-production form as an 80 seat passenger carrying vehicle and subsequently as a production version with a capability of carrying up to 101 passengers. Other versions of the AP.1-88 concept have also drawn considerable interest. Notably, the well-deck version which has shown to be a preference by at least 50% of the enquiries received from potential customers relating to both military and civil applications. As a logistic support vehicle for the Oil Industry, for example, it has a capability of carrying a wide variety of payloads, which can include wheeled vehicles, oil drilling pipes, casings, etc., and modules for the accommodation of additional crew or passengers or medical first-aid facilities.

Other missions include pollution control, medical evacuation, search and rescue, light station supplies and ice-breaking for flood control and seaway operation.

This paper describes the variant specially adapted as a logistic support vehicle for use in the Arctic and similar low temperature areas, and developed from a background of successful cold weather experiences with SR.N5, SR.N6 and BH.7 hovercraft. From these experiences it has been shown that the hovercraft has a proven role as a transportation vehicle and can be operated both profitably and successfully in cold regions.

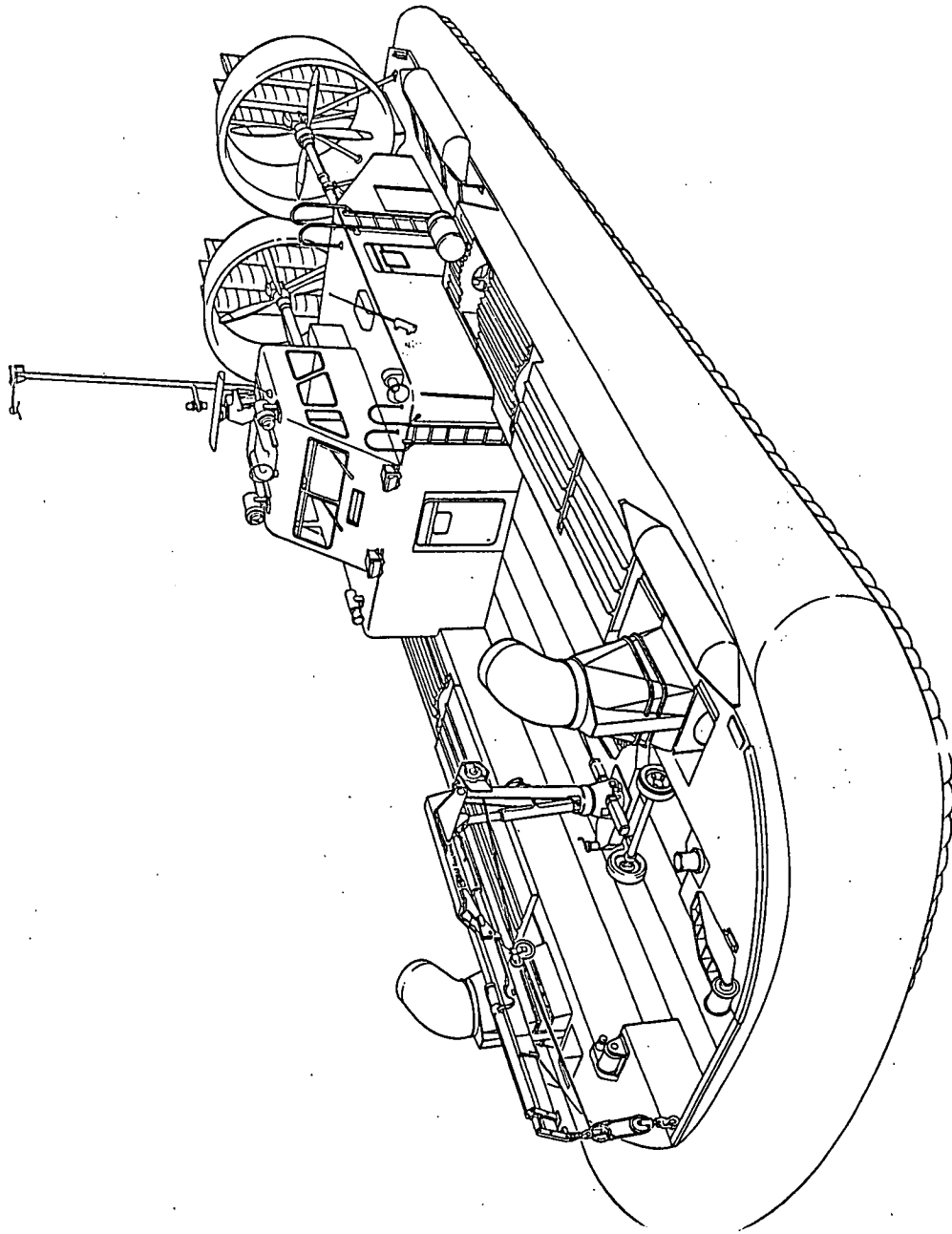

Canadian Coast Guard AP. 1-88 based in Montreal

CANADIAN COAST GUARD AP.1-88 (Delivered Sept. 1987)

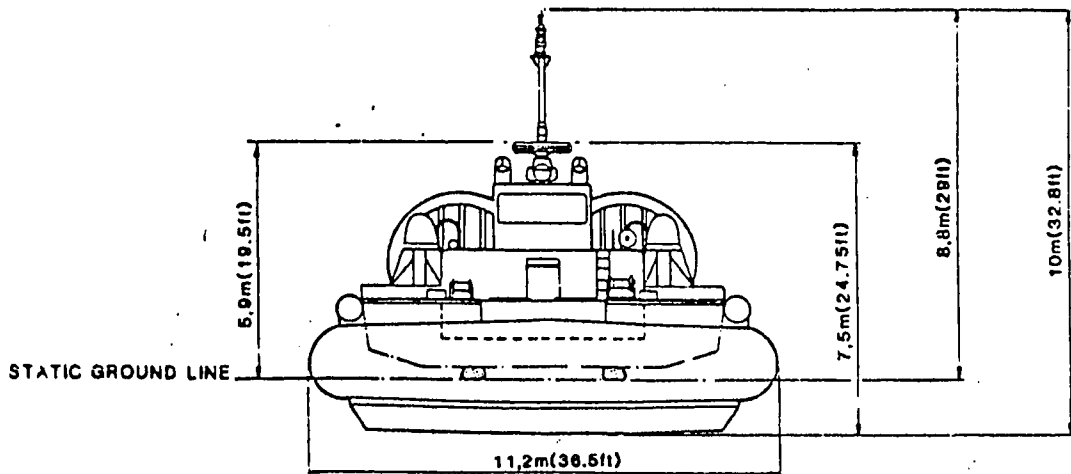
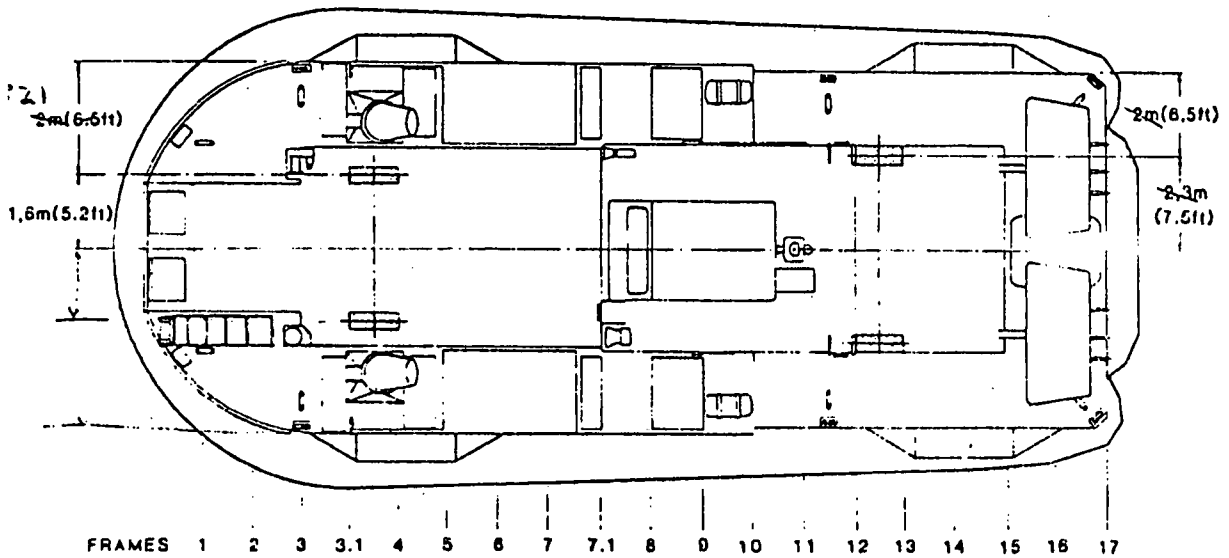
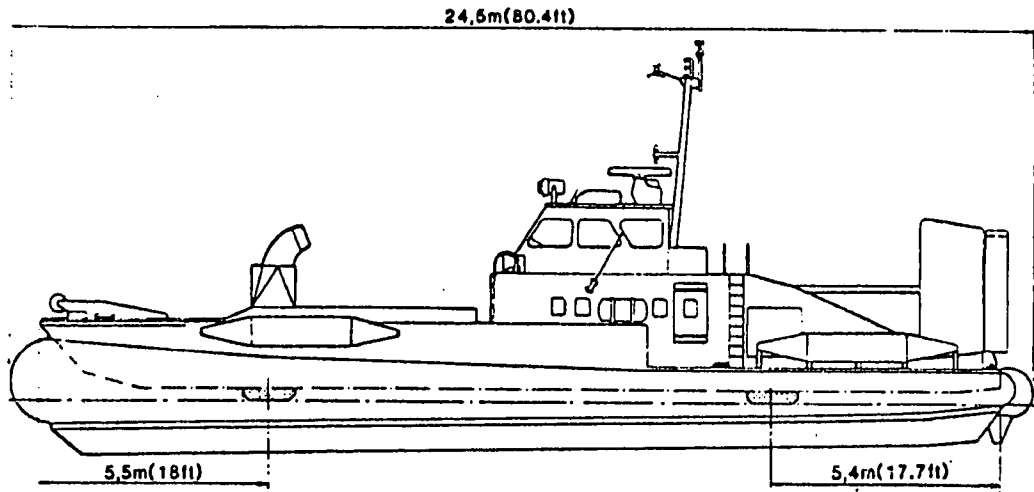

SRN-6 AIR CUSHION VEHICLE (A.C.V.)

A.C.V. (Hovercraft) - a vehicle which is designed to be supported when in motion wholly or partly by air expelled from the vehicle to form a cushion of which the boundaries include the ground, water or other surface beneath the vehicle.

Home Base - Vanc. Int'l Airport, Sub-base at Parksville
 Search And Rescue (S.A.R.) Crew composed of a Captain, 1st Officer and S.A.R. Specialist

Base operates 24 hrs a day including days of zero visibility, winds in excess of 40 knots and seas in excess of 3m. (10 ft.)

Length - O.A. 14.76 m. (48 ft. 5 in.)

Beam - 7.72 m. (25 ft. 4 in.)

Weight - 8618 kg. (19,000 lbs.)

Speed - max. 60 knots, 69 mph, 111 km/hr.
 - cruise speed 40 knots, 46 mph, 74 km/hr.

Range - normal 6.5 hrs.
 - max. 9.0 hrs.

Fuel - Jet A
 - also Jet B, Arctic Diesel or Stove Oil

Fuel capacity - normal 2111 l. (465 gal.)
 - max. 3019 l. (665 gal.)

Craft burns an average of 300 l. (65 gal.) per hour

Area of operation - Strait of Georgia, Fraser River, Gulf Islands, Vancouver Harbour

Craft Legend

1. VHF Antenna (2)
2. Nite Sun (2)
3. Storage locker for pumps
4. Radar
5. HF Antenna
6. VHF Antenna
7. VHF Directional Finding Antenna
8. UHF Antenna
9. Transponder
10. Night Fighter Search Light

11. VHF Antenna A.M. (Aircraft)
12. CB Antenna
13. VHF Antenna F.M. (Marine, Police, Ambulance)
14. Engine (1) - Gnome (Rolls Royce) Free Turbine
 Normal - 900 H.P. Max - 1200 H.P.
15. Exhaust Stack
16. Propeller - Hamilton Standard
 3-bladed, variable pitch

Propulsion Lift System

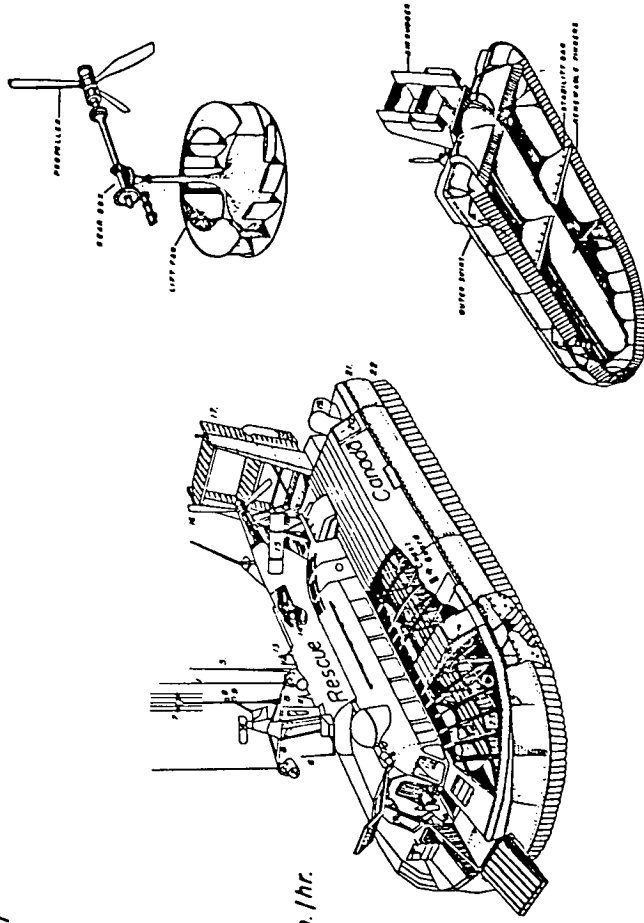

The lift fan provides the air cushion. The power is split through a combined gear box at a ratio of 3:1. The average running R.P.M. is 600 for the lift fan and 1800 for the propeller.

The air cushion of the SRN-6 is approx. 28 lbs. per sq. ft. (0.19 lbs per sq. in.). It raises the hard structure of the craft 1.2 m. (4.0 ft.) above the surface.

17. Air Rudder (2)
18. Lift Fan - 2.15 m. (7 ft.) in diameter
19. Doppler (Speed Indicating Radar)
20. Puff Port (4) each operate independently
21. Skirt
22. Fingers
23. Buoyancy Tank

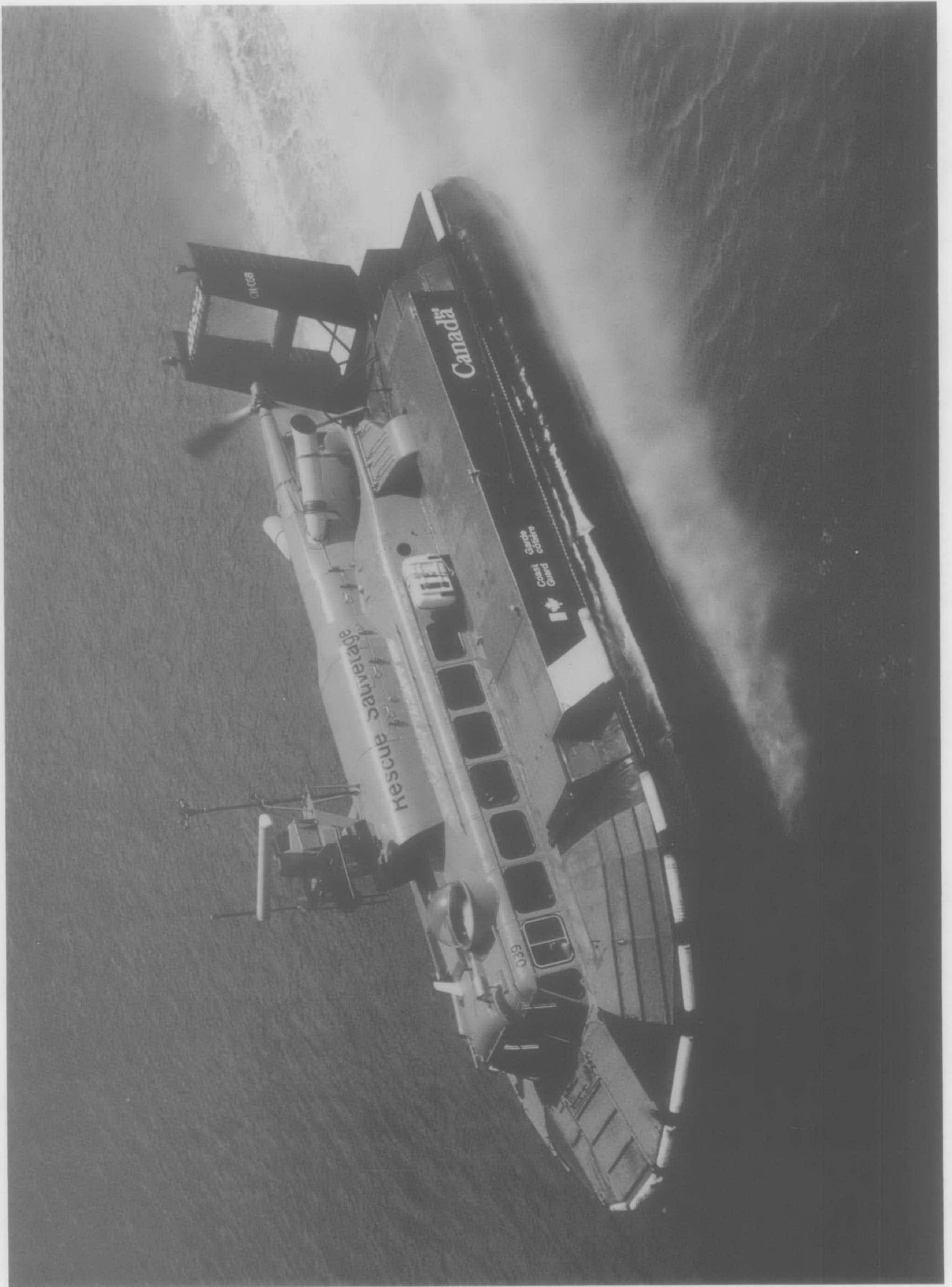

CG 039

Canada

Rescue Sauvage

039 CGS

Coast Guard
Garde côtière

S.P. 1115
 Book I, Prelims
 A.L. 9, June '73

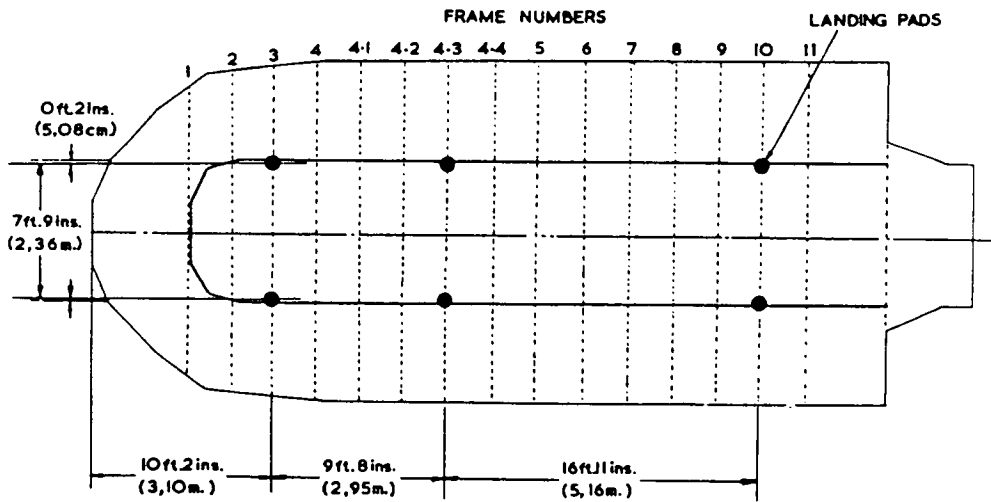
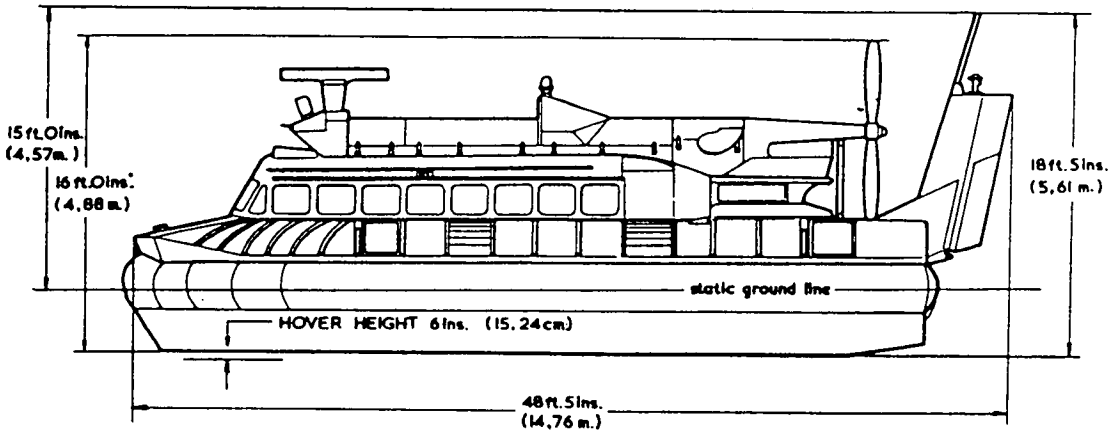

CABIN:

- LENGTH 21ft 9ins. (6.62m.)
- WIDTH 7ft.8ins. (2.34m.)
- HEADROOM 6ft.0ins. (1.83m.)
- DOOR APERTURE Height 5ft.9ins. (1.75m.)
- Width 3ft.3ins. (0.99m.)

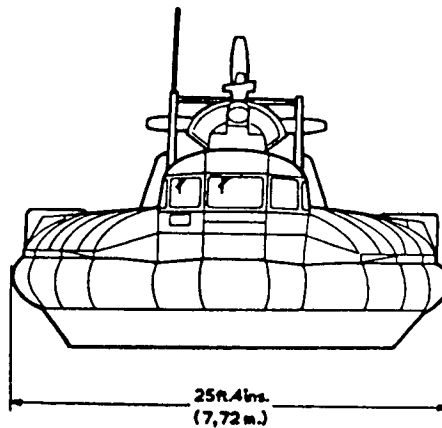

General arrangement

◀ SKIRT OUTLINE AND MEASUREMENT ALTERED ▶

SR.N6 as operated by the Canadian Coast Guard (Vancouver)

AHL

ARCTIC HOVERTRANS LTD.

Suite 1900, Esso Plaza, East Tower

425 - 1st Street S.W.

Calgary, Alberta T2P 3L8

The Air Cushion Vehicle "Larus"

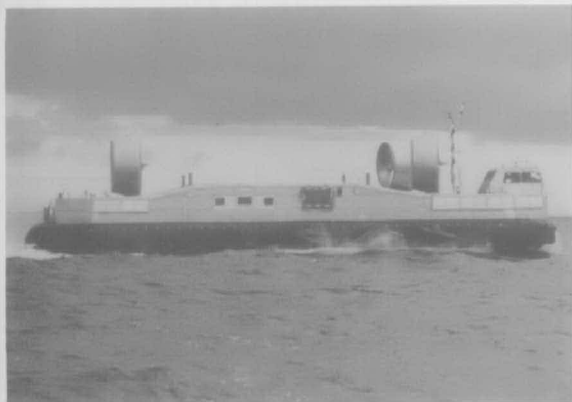

The Arctic Alternative

The air cushion vehicle "Larus" is the Arctic alternative providing the capability of transporting cargoes and passengers along most terrain and virtually any water depth, ice, wind and weather condition experienced in the North American Arctic. The "Larus" is aluminum constructed and capable of carrying approximately 25 tonnes cargo at a cruising speed of 20 knots. The craft may also accommodate 46 passengers in comfortable individual seats within the two hull superstructures.

The vehicle was designed and constructed, specifically for Arctic conditions, by Oy Wartsila Ab of Helsinki, Finland. The "Larus" has recently been refurbished to insure reliable operation in temperatures as low as -50°C . The machinery and materials of the craft have been selected with Arctic conditions in mind; from the main propulsion diesels to the re-inforced Arctic grade rubber skirt.

The "Larus" is propelled by four 650 KW diesel engines which drive integral lift fans and thrust propellers. The cushion is provided by six double centrifugal aluminum fans. The thrust is provided by four controllable pitch propellers in nozzles located upon pylons. The pylons rotate 240° providing the craft with excellent manoeuvring capability.

Among the many features of the "Larus" are mechanically operated ramps bow and stern to facilitate the handling of cargoes.

Larus Particulars

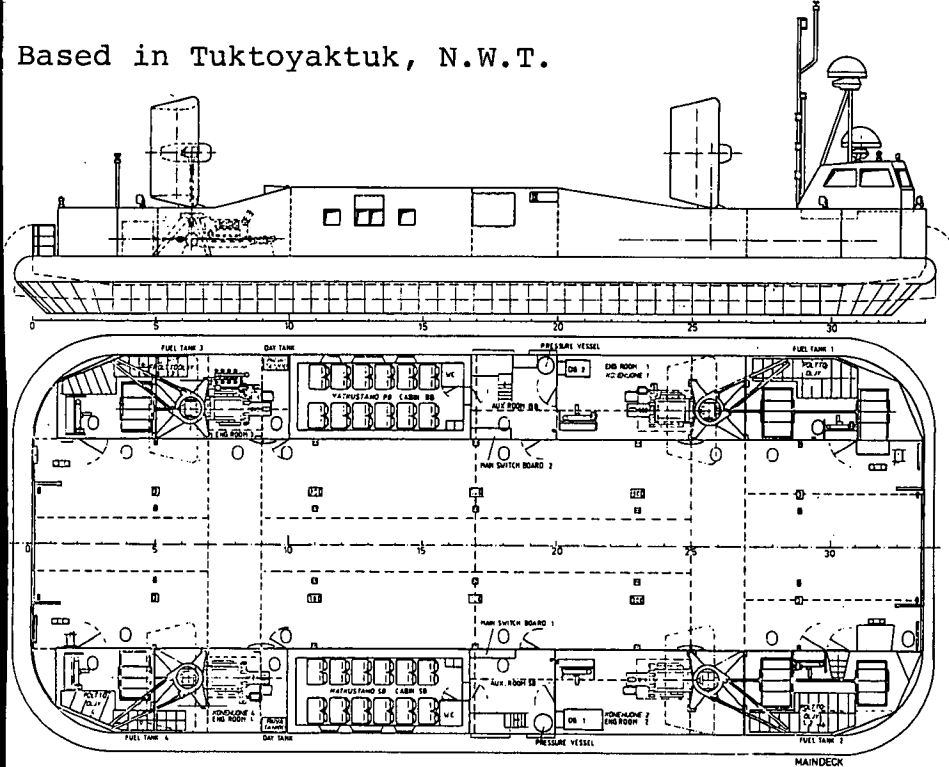

Main Propulsion Propellers:

Four four-bladed controllable pitch propellers 3.0 m diameter in ducts; one located at each corner of the vehicle; propeller blades are wood constructed with stainless steel leading edge; propellers and ducts located on pylons which rotate 240° (90° inwards, 150° outwards).

Steering:

Each propeller system individually controlled providing excellent manoeuvrability; propeller system electro-hydraulically controlled from control cabin or manually from engine room; control from cabin through steering wheel and foot pedals.

Crew:

Three persons; Pilot-in-Command, Navigator, Loadmaster.

Control Cabin:

Machinery is remotely controlled and monitored from a raised bridge located well forward on the starboard superstructure; seating is provided for all three crew members.

Skirt System:

Arctic grade, rubber nylon reinforced skirt, complete with anti-spray secondary skirt; loop and finger design which facilitates replacement skirt pieces.

Navigation and Communication Equipment

- Satellite navigator
- 2 radars
- Gyro compass with repeater
- Magnetic compass
- Inclinator
- Searchlights
- Signal lights
- VHF radios
- Anemometer
- SSB radios
- Intercom systems
- Signal lamp

Auxiliary Power:

Two diesel generators are fitted; one in each forward engine room; power available includes:

- 480 V, 3 phase, 60 Hz.
- 380 V, 3 phase, 50 Hz.
- 220 V, 3 phase, 50 Hz.
- 24 V, DC
- 12 V, DC

Regulations:

Constructed to I.M.O. Code and Canadian Coast Guard standards.

Lifesaving:

Lifesaving apparatus in accordance with Canadian Coast Guard requirements; two 25 person life rafts, one 10 person life raft, emergency locator, life jackets.

Registration: CH-AHL

Built: Helsinki, Finland (Oy Wartsila Ab), 1981

Dimensions:

Length — Overall	33.0 m
— Hull	32.0 m
Breadth — Overall	14.7 m
— Hull	13.5 m
Height — Overall (on "cushion") (approx.)	9.2 m
— Overall (on "parking pads")	8.2 m
— Hull	1.0 m
Lightship Weight	(approx.) 84 tonnes

Principal Capacities:

Deadweight —	(approx.) 25 tonnes
Deadweight — Maximum	(approx.) 35 tonnes
Fuel Oil Tanks — Maximum	8.9 tonnes
Clear Deck — Length	32.0 m
— Breadth	7.0 m
— Area	(approx.) 220 m ²
Max. All-up-weight—over water	105 tonnes
Max. All-up-weight—over solid surface	120 tonnes

Speed and Fuel Consumption (Level Terrain):

Maximum 25 knots @ approx. 0.5 tonnes/hr.

Endurance: One hour reserve

Max. continuous power	9.3 hr.
Economical cruise power (approx. 20 kts)	12.0 hr.
Hump speed	(approx.) 16 kts
Bollard pull	(approx.) 40 tonnes

Passenger Compartment:

Comfortable, individual seating for forty-six passengers in port and starboard hull cabins; washroom facility in each cabin; passenger compartments may also be used for transport of perishable items.

Ramps for Cargo Handling:

Mechanically controlled ramps bow and stern fitted to facilitate handling of roll-on roll-off cargoes; breadth of ramp—4.0 m.

Propulsion Machinery:

Four 650 kw high speed Isotta Fraschini diesel engines each driving centrifugal lift fan and four bladed, controllable pitch propulsion propeller in a surrounding duct; machinery located in four engine rooms in the hull superstructures; two individual rooms are provided for electrical and other ancillary equipment.

Lift System:

Six double-centrifugal fans driven by main propulsion diesel engines; forward diesels each connected to two double fans, rear diesels each connected to one double fan; vehicle capable of maintaining cushion with only two lift fan systems operating.

Cushion Pressure:

Approximately 2500 Pa

*Particulars of unit believed correct but subject to change.