Environmental
Studies
Research
Funds

166

Cuttings Treatment Technology Evaluation

July 2009



Government
of Canada

Gouvernement
du Canada

Canada

Correct citation for this report is:

Jacques Whitford Stantec Limited, July 2009
Cuttings Treatment Technology Evaluation
Environmental Studies Research Funds Report No. 166. St. John's, NL. 100 p

The Environmental Studies Research Funds are financed from special levies on the oil and gas industry and administered by the National Energy Board for the Minister of Natural Resources Canada and the Minister of Indian Affairs and Northern Development.

The Environmental Studies Research Funds and any person acting on their behalf assume no liability arising from the use of the information contained in this document. The opinions expressed are those of the authors and do not necessarily reflect those of the Environmental Studies Research Funds agencies. The use of trade names or identification of specific products does not constitute an endorsement or recommendation for use.

Printed under the auspices of the
Environmental Studies Research Funds

Cat. No. NE22-4/166E (Print)
ISBN 0-921652-85-2

Cat. No. NE22-4/166E-PDF (On-line)
ISBN 978-1-926750-05-7

To view a colour version of this publication, visit us online at esfunds.org/pubpub_e.php

© Her Majesty the Queen in Right of Canada, 2009



Recycled paper

Environmental Studies Research Funds
Report No. 166

July 2009

Cuttings Treatment Technology Evaluation

by



Stantec

Jacques Whitford Stantec Limited
3 Spectacle Lake Drive
Dartmouth, NS B3B 1W8
Tel: 902-468-7777
Fax: 902-468-9009

TABLE OF CONTENTS

EXECUTIVE SUMMARY	1
RESUMÉ	5
1.0 INTRODUCTION	9
1.1 GENERAL	9
1.1.1 Technical Advisory Group	9
1.1.2 Supporting Contributors	10
1.2 OBJECTIVES AND SCOPE	10
1.3 STUDY APPROACH AND METHODS	11
2.0 DRILLING MUDS CHARACTERIZATION	12
2.1 PHYSICAL	13
2.2 CHEMICAL	13
2.3 CONTAMINANTS	14
3.0 REGULATORY STANDARDS AND GUIDELINES	14
3.1 CURRENT NATIONAL REGULATIONS AND GUIDELINES	14
3.2 OTHER REGIONS AND JURISDICTIONS	15
3.2.1 United States	15
3.2.1.1 Gulf of Mexico	16
3.2.2 Rationale for Gulf of Mexico Limitations	19
3.2.3 Norway	21
3.2.4 North Sea	22
3.2.5 Australia	23
3.2.6 Brazil	24
3.3 MEASURING SBM AND CUTTINGS COMPLIANCE	24
3.4 FURTHER INFORMATION ABOUT BEST MANAGEMENT PRACTICES	26
4.0 DRILL CUTTINGS TREATMENT TECHNOLOGY	27
4.1 TREATMENT TECHNOLOGY OVERVIEW	27
4.2 DRILLING PLATFORM SOLIDS-CONTROL SYSTEMS	30
4.2.1 Primary Treatment Systems	30
4.2.1.1 Shakers	31
4.2.1.2 Hydrocyclones	32
4.2.1.3 Centrifuges	33
4.2.2 Secondary Treatment Systems	34
4.2.2.1 Cuttings Dryers	35
4.2.2.2 Thermal Desorption Methods	36
4.3 OTHER TECHNOLOGIES	38
4.4 ALTERNATIVE CUTTINGS MANAGEMENT OPTIONS	40
4.4.1 Cuttings Re-Injection	40
4.4.2 Ship-to-Shore Cuttings Disposal	41
5.0 TECHNOLOGY PERFORMANCE	43
5.1 DRILL CUTTINGS DISCHARGE QUALITY	43
5.1.1 Summary of Recent Studies	43
5.1.2 Data Assessment of Recent East Coast Operator Equipment Performance	44
6.0 ENVIRONMENTAL EFFECTS MONITORING	49
6.1 REVIEW OF RECENT PUBLICATIONS	49

6.2	GENERAL CONCLUSIONS OF RECENT EEM STUDY REVIEWS	50
7.0	CONCLUSIONS	54
8.0	CLOSURE	57
9.0	REFERENCES	57

LIST OF APPENDICES

APPENDIX A	International Requirements for Discharge of Drilling Mud & Cuttings.....	64
APPENDIX B	Summary of Recent Mud and Cuttings Offshore Discharge EEM Studies.....	82

LIST OF FIGURES

Figure 4-1	Circulation of drilling fluid during drilling and suspension and removal of drill cuttings (OGP, 2003).....	27
Figure 4-2	Photograph of drill cuttings (UKOOA website)	28
Figure 4-3	Schematic flow chart showing separation of drill cuttings from drilling fluids and options for cuttings disposal. (OGP, 2003).....	28
Figure 4-4	Solids-control equipment optimum particle size cut points. (Marinescu et al., 2007).....	31
Figure 4-5	Example of shaker equipment (MI-SWACO, 2008)	31
Figure 4-6	Typical shaker screening operation (CAPP, 2001).....	32
Figure 4-7	Desander hydrocyclone (MI-SWACO, 2008)	32
Figure 4-8	Hydrocyclone application (CAPP, 2001).....	33
Figure 4-9	Decanter centrifuge (MI-SWACO, 2008).....	33
Figure 4-10	Cross-section of a decanting centrifuge (CAPP, 2001).....	34
Figure 4-11	Example solids-control system for SBM drill cuttings, including secondary vertical cuttings dryer. (OGP, 2003)	34
Figure 4-12	Vertical cuttings dryer (MI-SWACO, 2008)	35
Figure 4-13	Example of a rotary kiln-type thermal desorption plant for onshore treatment of drill cuttings. (Jacques Whitford, 2002)	36
Figure 4-14	TCC heat generation mechanics. (Murray et al., 2008).....	36
Figure 4-15	TCC thermal desorption system for offshore or onshore application (Thermtech, 2008)	37
Figure 4-16	Schematic of pilot scale microwave cuttings treatment unit. (Robinson et al., 2008)	38
Figure 4-17	Typical Re-Injection Equipment Lay-out. (Gidatec website, 2008)	40
Figure 4-18	Cuttings Re-Injection Options (MI-SWACO, 2008).....	40
Figure 4-19	Waste injection system (MI-SWACO, 2008).....	41
Figure 4-20	Diagram of a “skip and ship” operation (From: Kirkness and Garrick, 2008).....	41
Figure 5-1	Summary of Equipment Configuration Statistics.....	47

LIST OF TABLES

Table 3.1	Drill Mud and Cuttings Effluent Discharge Limits U.S. Gulf of Mexico Outer Continental Shelf.....	18
Table 4.1	Framework of parameters for evaluating disposal options (OGP, 2003)	30
Table 5.1	Summary of Previous ROC Study Findings	43
Table 5.2	Per Well Mass Weighted %SOC.....	45
Table 5.3	Summary of %SOC Removal by Configuration Grouping	46

EXECUTIVE SUMMARY

The Environmental Studies Research Funds (ESRF) sponsored a technical report compiling information on technologies and performance data relative to the treatment and disposal of synthetic based mud (SBM) drill cuttings associated with offshore oil and gas drilling activities. This review focused mainly on Canadian Atlantic East Coast operations and drew upon experience acquired in the Gulf of Mexico, North Sea and elsewhere. After produced water, drill cuttings are the next largest discharge (by volume) into the marine environment from drilling activities, and are a key concern in all jurisdictions that support offshore oil and gas operations. Reviewing the period from 2002 to 2008, the study summarized various regulatory standards and guidelines around the world pertaining to synthetic based mud (SBM) cuttings disposal, updated the current state of cuttings treatment technology, assessed technology performance on Canada's East Coast and provided a summary of environmental effects monitoring from numerous jurisdictions.

The outcomes of this study are intended to provide updated information from 2002 to present on this subject, since the publication of the Offshore Waste Treatment Guidelines in August 2002. The key results and conclusions from this study are as follows.

SBM DRILL CUTTINGS CHARACTERISTICS

- SBMs have been developed in recent years to provide the oil and gas industry with an environmentally improved alternative to oil based muds (OBMs). A distinguishing characteristic of SBMs is the use of a synthetic base fluid (SBF) instead of water or oil. Because SBMs have low toxicity and high biodegradability, cuttings generated with these muds have been permitted for offshore discharge in many jurisdictions, often subject to effluent limits.
- SBFs are prepared synthetically and, as such, are well characterized and free of substantial impurities. The base fluids in SBFs are synthesized organic compounds that do not contain the toxic components found in refined oils, such as aromatics and cyclic structures. The most common SBM types include esters, ethers, iso-alkanes, poly-alpha-olefins, detergent alkylate, linear alpha-olefins, isomerized olefins, and dimethyl siloxane-based oligomeric siloxanes (Hart et al., 2007).
- Metal concentrations in SBFs are expected to be similar to those in water based muds (WBMs). With the exception of barium, metal concentrations are typical of the range measured in uncontaminated marine sediments (Neff et al., 2000). SBFs typically do not contain polynuclear aromatic hydrocarbons (PAHs).

REGULATORY STANDARDS AND GUIDELINES

- The disposal of drill mud and cuttings in Eastern Canada is currently controlled under the Offshore Waste Treatment Guidelines, 2002. Under these Guidelines, drill cuttings associated with SBM are to be re-injected, and where this option may not be technically feasible, the cuttings may be discharged to sea provided that they are treated first with the best available technology. When these guidelines were published, the best available treatment technology in some regions of the world was believed to be 6.9 g/100 g or less of oil on wet solids, and 6.9% was set as the allowable discharge limit for synthetic oil on cuttings (SOC). This discharge limit may be modified in individual circumstances where more challenging

formations and drilling conditions are experienced or areas of increased environmental risk are identified. In Nova Scotia, the 6.9% target has been reached through a combination of treatment system technologies and other management controls, such as ship to shore.

- The SOC concentration of 6.9% noted in the Canadian Offshore Waste Treatment Guidelines (2002) was based on the United States Environmental Protection Agency (USEPA) results obtained from the Gulf of Mexico. This retention on cuttings limit was developed by the USEPA based on a statistical analysis of data from 65 wells and representing four cuttings dryer technologies (USEPA, 2000c). In this study, the USEPA noted that the well average retention on cuttings measurements from Canada were all higher than those found in the Gulf of Mexico, arguing that the Canadian data do not belong to the same probability distribution as that associated with the data from the Gulf of Mexico. USEPA concluded that because these technologies appear physically and statistically different, a single distribution for retention on cuttings from any combination of cuttings dryer technologies does not exist for multiple regions (USEPA 2000b). The difference in retention on cuttings appears to be associated with variations/differences in geological formations (coarser materials generally associated with the Gulf of Mexico), and differences in the well bottom hole assemblies, all resulting in higher % SOC in the Canadian offshore wells.
- The majority of the technology-based limitations pertaining to the disposal of SBM on cuttings, worldwide, are related to percentage retention of mud on cuttings. The Gulf of Mexico has additional limitations, including toxicity testing and biodegradation. Australia has added a limitation stipulating the size of the drill hole for which SBM may be discharged. Other countries, including Norway, have prescribed environmental monitoring programs as a means of measuring treatment performance, and still others have no restrictions on the disposal of SBM.

DRILL CUTTINGS TREATMENT TECHNOLOGY

- The primary function of a typical solids-control treatment system is to efficiently remove the solids from the treatment stream in order to maximize the recovery and recycling of the costly drilling fluids. Maximizing the recycling of drilling fluid also reduces the total volume of spent SBM drill fluids that must be disposed of upon completion of drilling operations.
- Based on the definitions drafted by the Association of Oil & Gas producers (OGP, 2003), primary treatment systems are aimed at solids removal and drill fluids recovery, and compliance with environmental requirements. Secondary treatment systems are additional equipment that may be added to increase drilling fluid recovery and/or help comply with stringent regulatory requirements for offshore cuttings discharge.
- Various types of primary solids control equipment (e.g., shakers, centrifuges) continue to be the main components used to remove SBMs on cuttings. Although refinements have been made to primary treatment equipment, these technologies remain relatively similar to 2002 designs. There is no one specific treatment process that can be defined for all primary solids-control applications. The number and type of system components are selected according to site-specific drilling requirements (e.g., volumes to be treated, variability in formation, production rate), and brought online or offline during the course of drilling operations, as required.

- The two most common methods for secondary treatment to reduce drilling fluid retention on cuttings (ROC) are cuttings dryers and thermal desorption. Although other innovative technologies, such as microwave treatment, have been studied, they are not available on a full-scale commercial basis.
- The design of cuttings dryers consists of a fine mesh screen mounted on a rotating basket that generates centrifugal forces for separation. The centrifuge may be horizontally or vertically oriented (Cannon and Martin, 2001). The Verti-G™ cuttings dryer from MI-SWACO is an example of vertical mounted cuttings dryer. The Duster™ from Hutchison Hayes uses a horizontal screen configuration.
- In the thermal desorption process, cuttings are heated to the distillation temperature of the base oil, and this temperature is maintained until essentially all of the oil is vaporized. When first developed, thermal desorption required large, fixed onshore facilities because of the space and energy requirements. A thermo-mechanical cuttings cleaner (TCC) system, also known as a hammermill system, has been successfully used both onshore and offshore. The cuttings powder resulting from this process typically has a hydrocarbon content of <0.1%.
- In addition to offshore treatment and disposal, alternative methods for the disposal of drill cuttings include cuttings re-injection (CRI), or transport of the cuttings to shore for onshore treatment and/or disposal (i.e., ship-to-shore). Significant advancements have been made in the last decade with CRI. The process requires intricate design and is subject to reservoir constraints. For ship-to-shore, a key safety concern is the large number of crane lifts needed to transfer cuttings boxes between drilling rigs and onshore facilities. Cuttings handling and transport also poses logistical challenges because of the limited storage space available on offshore drilling rigs.

TECHNOLOGY PERFORMANCE

Drill cuttings treatment performance was based on information received from two major operators on the Canadian East Coast from 2002 to 2007.

- The study results indicate that on a whole well basis the 6.9% SOC is seldom achieved (1 out of 15 wells in the Eastern Canada examples that were studied achieved 6.9% SOC between 2002 and 2007). It was found that the per-well mass average % SOC was 8.46%.
- Four equipment configurations discharged the greatest weight of cuttings. Of these top four, the average percent synthetic on cuttings (% SOC) ranged from 7.09 to 9.55.
- During specific periods of treatment, a 6.9% SOC was achieved. However, the associated treated mass of cuttings discharged (less than 6.9% SOC) represented less than 10% of the total treated mass of 15 assessed wells.
- One operator reported that drilling operations conducted in the Nova Scotia offshore in 2002 were able to achieve the 6.9% SOC through use of a Verti-G™ cuttings dryer, combined with ship-to-shore transport of some drilling wastes. However, the provided data did not allow for an assessment of the Verti-G™ cuttings dryer stand-alone performance.

ENVIRONMENTAL EFFECTS MONITORING

- The environmental effects on benthic communities from SBM drill cuttings discharge appear to be generally limited to within 500 metres of the discharge point. This area may be extended at production drilling areas where volume and duration of discharges are greater. Available data from Environmental Effects Monitoring Studies indicate that SBMs do not appear to pose a risk of specific ecotoxicological effects. SBMs typically do not contain polycyclic aromatic hydrocarbons (PAHs), and with the exception of barium, metal concentrations are usually similar to the range measured in uncontaminated marine sediments.
- SBMs are not expected to bioaccumulate significantly because of their extremely low water solubility and consequent low bioavailability. Their propensity to biodegrade further reduces the likelihood that exposures will be long enough for a significant bioaccumulative hazard to result. Cuttings discharged with SBFs have resulted in smaller zones of impact on the seafloor, and the biological community recovers more rapidly (OGP, 2003).
- At sites where SBMs were used, field studies (see Appendix B) typically show that strong indications of recovery occur within one to five years from cessation of discharges.

In summary, this study has concluded that technologies available for the treatment of drill cuttings have remained essentially unchanged since 2002, with the exception of advances in cuttings dryers and thermal desorption technologies. Performance of offshore treatment systems for SBM drill cuttings from 2002 to 2007 rarely achieved the 6.9% SOC concentration on a “per well” basis, based on the reviewed information. These results are consistent with the USEPA findings in 2000 that also reviewed data from Canada. The environmental effects on benthic communities from SBM drill cuttings discharge appear to be generally limited to within 500 metres of the discharge point for exploration drilling. At sites where SBFs were used, field studies typically show that strong indications of recovery occur within several years.

RÉSUMÉ

Le Fonds pour l'étude de l'environnement (FEE) a commandité un rapport technique compilant des renseignements sur les technologies utilisées et le rendement des systèmes de traitement et d'élimination des déblais de forage imprégnés de boues synthétiques, associés aux activités de forage de puits de pétrole et de gaz naturel en mer. Ce rapport s'est concentré principalement sur les activités ayant lieu sur la côte Est du Canada atlantique tout en se fondant sur l'expérience acquise dans le golfe du Mexique, la mer du Nord et ailleurs. Après l'eau produite, les déblais de forage représentent le deuxième plus important rejet (en volume) en mer dans le cadre d'activités de forage et préoccupent grandement tous les organismes qui appuient les opérations pétrolières et gazières au large des côtes. Examinant la période entre 2002 et 2008, l'étude a fait un résumé de diverses normes et directives de réglementation dans le monde concernant l'élimination des déblais imprégnés de boues synthétiques, une mise à jour de l'état actuel des technologies de traitement des déblais, une évaluation du rendement des technologies utilisées sur la côte Est du Canada ainsi qu'un résumé des suivis des effets sur l'environnement effectués par de nombreux organismes.

Les résultats de l'étude sont destinés à la mise à jour des renseignements qui remontent à 2002 sur ce sujet, soit depuis la publication des *Lignes directrices relatives au traitement des déchets dans la zone extracôtière* en août 2002. Ci-après se trouvent les résultats et conclusions clés de cette étude :

CARACTÉRISTIQUES DES DÉBLAIS IMPRÉGNÉS DE BOUES SYNTHÉTIQUES

- Les boues synthétiques ont été développées au cours des dernières années afin de donner à l'industrie pétrolière et gazière une meilleure solution pour l'environnement en remplacement des boues à base d'huile. Les boues synthétiques se distinguent par l'utilisation d'un fluide à base synthétique au lieu de l'eau ou de l'huile. Puisque les boues synthétiques sont peu toxiques et hautement biodégradables, les déblais qui en sont imprégnés peuvent être rejetés en mer dans de nombreux pays, souvent sous réserve de limites en matière d'effluents.
- Les fluides à base synthétique sont préparés synthétiquement et comme tels, ils ont des caractéristiques bien définies et sont exempts d'impuretés substantielles. Les fluides de base sont des composés organiques synthétisés qui ne contiennent pas les éléments toxiques trouvés dans les huiles raffinées telles que les aromatiques et les structures cycliques. Les types de boues synthétiques les plus courants comprennent les esters, les éthers, les iso-alcanes, les poly-alpha-oléfinés, les alkylats détergents, les alpha-oléfinés linéaires, les oléfinés isomérisés et les siloxanes oligomériques à base de diméthyl siloxane (Hart et al., 2007).
- Les concentrations métalliques dans les fluides à base synthétique devraient être similaires à celles dans les boues à base d'eau. À l'exception du baryum, les concentrations de métaux sont caractéristiques de l'étendue des valeurs mesurées dans les sédiments marins non contaminés (Neff et al., 2000). En général, les fluides à base synthétique ne contiennent pas d'hydrocarbures aromatiques polycycliques.

NORMES ET DIRECTIVES DE RÉGLEMENTATION

- L'élimination des boues et déblais de forage dans l'Est du Canada est actuellement contrôlée selon les *Lignes directrices relatives au traitement des déchets dans la zone extracôtière* de 2002. Conformément à ces lignes directrices, les déblais de forage imprégnés de boues synthétiques doivent être réinjectés et

si cette option n'est pas techniquement faisable, ils peuvent être rejetés en mer à condition de les traiter préalablement au moyen des meilleures technologies disponibles. À l'époque où ces lignes directrices étaient publiées, le traitement selon la meilleure technologie disponible dans certaines régions du monde aurait été de 6,9 g par 100 g ou moins d'huile sur des solides mouillés et le taux de 6,9 % a été établi comme étant la limite autorisée de rejet pour l'huile synthétique dans les déblais (HSD). Cette limite de rejet peut être modifiée dans des circonstances particulières où l'on fait face à des formations et des conditions de forage plus difficiles ou s'il y a des zones de risques environnementaux accrus. En Nouvelle-Écosse, la cible de 6,9 % a été atteinte grâce à une combinaison de technologies de traitement et d'autres contrôles de gestion tels que le transfert mer-terre.

- La concentration HSD de 6,9 % notée dans les Lignes directrices relatives au traitement des déchets dans la zone extracôtière (2002) était basée sur les résultats obtenus par l'USEPA dans le golfe du Mexique. Cette limite de rétention dans les déblais a été établie par l'USEPA d'après une analyse statistique de données provenant de 65 puits et représentant quatre technologies d'essorage de déblais (USEPA, 2000c). Dans cette étude, l'USEPA a noté que les mesures de rétention dans les déblais en moyenne par puits provenant du Canada étaient toutes plus élevées que celles trouvées dans le golfe du Mexique, présentant comme argument que les données canadiennes ne faisaient pas partie de la même distribution de probabilité que les données provenant du golfe du Mexique. L'USEPA a conclu qu'il n'y avait pas une distribution unique pour la rétention dans les déblais, obtenue à partir d'une combinaison de technologies d'essorage de déblais, pour plusieurs régions étant donné que ces technologies semblaient être physiquement et statistiquement différentes (USEPA, 2000b). La différence au niveau de la rétention dans les déblais semble être liée à la variation ou aux différences dans les formations géologiques (matériaux plus grossiers généralement associés au golfe du Mexique); cela et les différences dans les garnitures de fond de puits font que la concentration HSD dans les puits canadiens en mer est plus élevée.
- Partout dans le monde, la majorité des restrictions fondées sur la technologie et relatives à l'élimination des déblais imprégnés de boues synthétiques portent sur le taux de rétention des boues dans les déblais. Le golfe du Mexique est soumis à d'autres mesures, dont l'essai de toxicité et la bioaccumulation. L'Australie a ajouté une mesure stipulant la grosseur du puits dans lequel les boues synthétiques peuvent être déversées. D'autres pays, dont la Norvège, ont imposé des programmes de surveillance de l'environnement comme moyen de mesurer le rendement du traitement et d'autres pays n'ont aucune restriction concernant l'élimination des boues synthétiques.

TECHNOLOGIES DE TRAITEMENT DES DÉBLAIS DE FORAGE

- La fonction principale d'un système de traitement type pour le contrôle des solides est d'éliminer efficacement les solides du flot de traitement afin d'optimiser la récupération et le recyclage des fluides de forage qui coûtent cher. L'optimisation du recyclage des fluides de forage réduit également le volume total de fluides contenant des boues synthétiques à éliminer à la fin des activités de forage.
- D'après les définitions établies par l'OGP (l'association internationale des producteurs de pétrole et de gaz) en 2003, les systèmes de traitement primaire visent à éliminer les solides et à recycler les fluides de forage ainsi qu'à satisfaire aux exigences en matière de conformité environnementale. Les systèmes de traitement secondaire sont d'autres équipements qui peuvent être ajoutés pour augmenter la récupération des fluides de forage et aider à répondre aux exigences réglementaires strictes concernant le rejet de déblais en mer.
- Les premiers dispositifs de contrôle des solides (p. ex., tamis vibrants, centrifugeuses) continuent à être les principaux éléments dans l'élimination des boues synthétiques dans les déblais. Malgré le perfectionnement

des premiers systèmes de traitement, ces technologies demeurent relativement semblables aux conceptions de 2002. Il n'y a pas un processus de traitement particulier qui peut être défini pour toutes les principales applications destinées au contrôle des solides. Les éléments des systèmes sont sélectionnés en nombre et en type en fonction des exigences de forage propres au site et ils sont mis en réseau ou hors réseau durant les activités de forage suivant les besoins.

- Les deux méthodes de traitement secondaire les plus courantes pour réduire la rétention de fluide de forage dans les déblais sont l'essorage des déblais et la désorption thermique. Bien que d'autres technologies novatrices, comme le traitement par micro-ondes, aient été étudiées, elles ne sont pas disponibles à grande échelle commerciale.
- La conception des essoreurs de déblais consiste en un tamis à mailles serrées monté sur un panier rotatif qui génère des forces centrifuges pour produire la séparation. La centrifugeuse peut être orientée horizontalement ou verticalement (Cannon et Martin, 2001). L'essoreur Verti-G™ de MI-SWACO est un exemple où la centrifugeuse est montée verticalement. Le Duster™ de Hutchison-Hayes utilise une configuration de tamis horizontal.
- Dans le processus de désorption thermique, les déblais sont chauffés à la température de distillation de l'huile de base et cette température est maintenue jusqu'à l'évaporation totale de l'huile. Au début de sa création, la désorption thermique exigeait de grandes installations côtières fixes à cause de l'espace et de l'énergie qu'il fallait. Un nettoyeur de déblais thermo-mécanique, aussi appelé système de broyage à marteaux, a été utilisé avec succès aussi bien sur la côte qu'en mer. Les déblais réduits en poudre grâce à ce processus ont habituellement une teneur en hydrocarbures de < 0,1 %.
- Outre le traitement et l'élimination en mer, des solutions de rechange pour l'élimination des déblais de forage comprennent notamment la réinjection des déblais ou le transport des déblais vers la côte pour être traités et/ou éliminés sur terre (c.-à-d. transfert mer-terre). Des progrès significatifs ont été faits au cours de la dernière décennie dans la réinjection des déblais. Le processus exige une conception très élaborée et il est soumis à des contraintes de réservoir. Pour le transfert mer-terre, il y a une préoccupation clé au niveau de la sécurité car il faut un grand nombre de grues de levage pour transférer les boîtes de déblais des appareils de forage aux installations côtières. La manutention et le transport des déblais posent également des problèmes logistiques en raison de la disponibilité limitée de l'espace d'entreposage sur les appareils de forage en mer.

RENDEMENT DES TECHNOLOGIES

Le rendement du traitement des déblais de forage a été évalué en fonction des renseignements reçus de deux grands exploitants sur la côte Est du Canada de 2002 à 2007.

- Les résultats de l'étude indiquent que basé sur l'ensemble des puits, le taux de 6,9 % HSD est rarement atteint (dans les exemples de l'Est du Canada faisant partie de l'étude, 1 puits sur 15 a réalisé le taux de 6,9 % HSD entre 2002 et 2007). Il a été trouvé que le taux moyen de l'ensemble des puits était de 8,46 % HSD.
- Quatre configurations d'équipements ont totalisé la plus grande quantité de rejet de déblais. De ces quatre configurations, le taux moyen était de 7,09 % à 9,55 % HSD.
- Durant des périodes de traitement particulières, un taux de 6,9 % HSD a été atteint. Cependant, la masse traitée associée aux déblais rejetés (moins de 6,9 % HSD) a représenté moins de 10 % du total de masse

traitée pour les 15 puits évalués.

- Un exploitant menant des activités de forage au large de la Nouvelle-Écosse a déclaré qu'en 2002 il a réussi à atteindre 6,9 % HSD grâce à l'utilisation d'un essoreur Verti-G™ avec le transfert mer-terre d'une partie des déchets de forage. Toutefois, les données fournies n'ont pas permis d'évaluer le rendement de l'essoreur Verti-G™ utilisé tout seul.

SUIVI DES EFFETS SUR L'ENVIRONNEMENT

- Les effets environnementaux du rejet de déblais imprégnés de boues synthétiques sur les communautés benthiques semblent être généralement limités à l'intérieur de 500 mètres du point de rejet. Cette aire peut être étendue dans les zones de forage d'exploitation où le volume et la durée des rejets sont plus grands. Les données obtenues des études de suivi des effets sur l'environnement indiquent que les boues synthétiques ne semblent pas avoir des effets écotoxicologiques particuliers. En général, les boues synthétiques ne contiennent pas d'hydrocarbures aromatiques polycycliques et à l'exception du baryum, les concentrations de métaux se trouvent habituellement dans l'étendue des valeurs mesurées dans les sédiments marins non contaminés.
- Les boues synthétiques ne devraient pas produire une bioaccumulation significative en raison de leur extrême solubilité dans l'eau et la faible biodisponibilité résultante. Leur tendance à se biodégrader réduit encore plus la probabilité que les expositions soient assez longues pour causer un risque de bioaccumulation significative. Des déblais rejetés avec les fluides à base synthétique ont entraîné une réduction des zones d'impact sur le fond marin et la communauté biologique récupère plus rapidement (OGP, 2003).
- Sur les sites où des boues synthétiques ont été utilisées, des études sur le terrain montrent généralement qu'il y a de fortes indications que la récupération se fait de un à cinq ans après la cessation des rejets.

En résumé, cette étude a conclu qu'essentiellement, les technologies disponibles pour le traitement des déblais de forage n'ont pas évolué depuis 2002, hormis les progrès dans les technologies d'essorage des déblais et de désorption thermique. Le rendement des systèmes de traitement en mer des déblais imprégnés de boues synthétiques entre 2002 et 2007 a rarement atteint la concentration HSD de 6,9 %, calculée par puits, d'après les renseignements examinés. Ce résultat est conforme aux constatations en 2000 de l'USEPA qui a aussi examiné les données provenant du Canada. Les effets environnementaux du rejet de déblais imprégnés de boues synthétiques sur les communautés benthiques semblent être généralement limités à l'intérieur de 500 mètres du point de rejet dans un forage exploratoire. Sur les sites où des fluides à base synthétique ont été utilisées, des études sur le terrain montrent généralement qu'il y a de fortes indications que la récupération se fait quelques années plus tard.

1.0 INTRODUCTION

1.1 GENERAL

In January 2008, the Environmental Studies Research Funds (ESRF) administrators asked Jacques Whitford Stantec Limited (Jacques Whitford) to prepare a technical report compiling information on technologies and performance data relative to the treatment and disposal of synthetic based mud (SBM) drill cuttings generated from offshore oil and gas exploration and production activities.

Treatment of drill cuttings resulting from offshore oil and gas exploration and production is a key issue for the offshore oil and gas industry, regulators and stakeholders. Drill cuttings are a large discharge into the marine environment from offshore oil and gas operations. As such, regulation of the discharges associated with drill cuttings is a key concern in all jurisdictions that support offshore oil and gas operations.

Over the past decade, a variety of technologies have been developed and enhanced for the treatment of drill cuttings. This report provides an update of the status of these technologies and their ability to achieve results in reduction of synthetic on cuttings and comply with regulatory requirements. The current version of the Offshore Waste Treatment Guidelines (August 2002) issued by the National Energy Board, Canada Newfoundland & Labrador and Canada Nova Scotia Offshore Petroleum Boards set guidelines for the discharge of synthetic and other drill mud types into Canada's marine environment. This report has been prepared as a supplement to the updated guidelines and contains information from recent operations on Canada's East Coast, in the Gulf of Mexico and in other regions around the world.

1.1.1 TECHNICAL ADVISORY GROUP

Technical support and input for this report was provided by an ESRF Technical Advisory Group, consisting of representatives from industry and regulatory authorities. The Technical Advisory Panel provided input throughout the drafting of the document, including regulatory considerations, industry statistics and equipment information. The Technical Advisory Panel included representatives of the following:

- * Chevron
- * StatOil Hydro Canada
- * Husky Energy
- * Exxon Mobil
- * PetroCanada
- * Encana
- * Devon
- * Environment Canada
- * Fisheries and Oceans Canada
- * National Energy Board
- * Canada-Newfoundland Offshore Petroleum Board
- * Canada-Nova Scotia Offshore Petroleum Board

1.1.2 SUPPORTING CONTRIBUTORS

Jacques Whitford would like to acknowledge CSA International Inc. for its significant assistance in the updating of recent monitoring studies, drill mud characterization, updates of cuttings effluent limits for the Gulf of Mexico, and relevant information on controlling mud retention on cuttings. Jacques Whitford would also like to acknowledge MI-SWACO for its support in providing technical information on performance data for technologies over the past eight years.

1.2 OBJECTIVES AND SCOPE

The objectives of this study are to report on the current state of drill cuttings treatment technologies applicable to offshore drilling operations by conducting a literature review and consultations with industry (East Coast operators and suppliers), and to provide updated information from 2000 to present on this subject, since publication of the Offshore Waste Treatment Guidelines in August 2002.

The scope of this study includes current global “state-of-the-art” technologies available for SBM associated drill cuttings treatment for offshore drilling operations and an assessment of their effectiveness, benefits and disadvantages. The specific tasks carried out in this study were the following:

- Review cuttings discharge related material that was prepared for the 2002 Offshore Waste Treatment Guidelines Review;
- Conduct a review to identify results/experience with synthetic based mud (SBM) cuttings treatment since 2000, as available;
- Summarize the best available technology currently and potentially available in the immediately foreseeable future;
- Summarize operator experience with SBM cuttings treatment technology, specifically performance of cuttings treatment equipment currently used on facilities.
- Provide information on and summarize industry experience with new or emerging technologies that operators have been investigating since 2000. This included summarizing actual treatment performance achieved in terms of the percentage synthetic-on-cuttings (%SOC) of various East Coast operators, and where information was available, of operators in other jurisdictions worldwide.
- Compile information on chemical characterization (including potential contaminants) of drill cuttings discharge streams on a global basis, as available.
- Identify the potential for setting performance targets other than %SOCs, such as “total synthetic base fluid” load (discharged) on a well or hole section basis as a measure of environmental performance.
- Summarize the regulations or guidelines of various jurisdictions worldwide, to the extent available, as they relate to the discharge of cuttings (WBM and SBM), including regulations or guidelines that address the discharge of particular constituents such as heavy metals and other contaminants; and
- Provide an overall summary of the results obtained from recent Canadian (East Coast) and other relevant offshore oil and gas environmental effects monitoring programs regarding the environmental effects of discharges of SBM in cuttings.

It should be noted that the original scope of the study included the requirements (1) that the results and operator experience using water based muds (WBMs) and their effects as measured in environmental effects monitoring programs be reviewed, and (2) that an information summary be prepared of the environmental and safety implications and statistics, respectively, of ship to shore operations and onshore disposal of cuttings being carried out in other jurisdictions such as the North Sea. However, during the initial phases of the project, it was determined there were no data available for either of these two topics, and after discussions with the Technical Advisory Panel (TAP), these items were removed from the scope of the study.

1.3 STUDY APPROACH AND METHODS

This study was prepared following an extensive literature review that covered the published information on technologies and the effectiveness of equipment used to remove SBMs and WBMs on cuttings. It should be recognized that because there are no regulatory discharge limits for WBMs on the East Coast of Canada, this study focuses primarily on regulatory information and technologies associated with SBMs. A literature review was also the primary means of compiling related information on the status of regulations in other jurisdictions, environmental effects monitoring, and other statistics used and compiled in this study. The key reports that provided important information in support of this study are summarized in Section 5.1 and Section 7.0.

In addition to the literature review, interviews were conducted with numerous operators and manufacturers of SBM cuttings treatment systems to document the state of current technologies and identify new/emerging treatment systems.

With the support of the Technical Advisory Group, actual performance data were provided by two large drilling operators that have been active on Canada's East Coast for the past six years. These data were used extensively to document the ability of various equipment configurations to carry out current treatment activities.

2.0 DRILLING MUDS CHARACTERIZATION

Drilling muds are used for a number of purposes including the following (Neff et al., 2000):

- Transporting drill cuttings to the surface;
- Balancing the sub-surface and formation pressures, so that the pressure at the drill bit is greater than the pressure within the formation, to prevent a blowout; and
- To cool and lubricate the drill bit to reduce the friction between the drill pipe and the well bore.

There are two general types of drilling muds used in the East Coast, water-based drilling muds (WBM) and non-aqueous drilling muds (NADM). The drill mud percentages and constituents for both WBMs and NABMs indicated below vary, depending on a number of variables (mud weight, formation being drilled, depth etc). Consequently, some drill muds may not include some of the typical constituents indicated.

WBMs are made up of water mixed with bentonite clay and barite, to control mud density, as well as a number of other substances to achieve desired drilling properties including thinners, filtration control agents and lubrication agents. A typical WBM is made up of the following (OGP, 2003):

- 76% seawater
- 15% barite
- 7% bentonite, and
- 2% other

NABMs are emulsions of primarily non-aqueous material. The continuous phase is the non aqueous base fluid and the internal phase water and various chemicals (OGP, 2003). As with WBMs, other substances are added to NABMs to achieve desired drilling properties. For example, barite is added to achieve desired density; and proper viscosity is achieved by altering the base fluid to water ratio and using clay materials and emulsifiers to stabilize the water in oil emulsions. The base fluid also serves as a lubricating agent. The composition of a typical NABM consists of the following (OGP, 2003):

- 46% non-aqueous base fluid
- 33% barite
- 18% brine
- 2% emulsifiers, and
- 1% other

NABMs include oil-based muds (OBMs), enhanced mineral oil-based muds (EMOBMs) and synthetic-based muds (SBMs). OGP (2003) also defined three groupings of NABMs based on aromatic hydrocarbon concentrations, specifically:

- Group I (high aromatic content) – such as diesel oil based and conventional mineral oil based fluids;
- Group II (medium aromatic content) – such as low toxicity mineral based fluids; and
- Group III (low to negligible aromatic content) – such as synthetic hydrocarbons and highly processed mineral oils.

SBMs have been developed in recent years to provide the oil and gas industry with an environmentally improved alternative to OBMs. The distinguishing characteristic of SBMs is the use of a synthetic base fluid (SBF) instead of water or oil. Because SBMs have low toxicity and high biodegradability, cuttings generated with these muds have been permitted for offshore discharge in many jurisdictions, often subject to effluent limits.

2.1 PHYSICAL

One of the primary purposes of drilling muds is to transport drill cuttings to the surface. Drill cuttings are small pieces of rock produced by the grinding action of the drill as it penetrates the sub-surface. Drill cuttings tend to have an angular shape and can range in size from clay-like particles to coarse gravel (Neff et al., 2000). The physical composition of the cuttings reflects the geological materials making up the sub-surface that was penetrated, as well as other manufacturer-specific solid/chemical materials that had originally made up the drilling mud.

2.2 CHEMICAL

The various types of SBMs have a wide range of chemical properties. An important feature of SBMs is that they are prepared synthetically and, as such, are well characterized and free of substantial impurities. SBMs are relatively simple in composition when compared with crude and refined petroleum.

The base fluid or continuous phase of an SBM is a water-insoluble synthetic organic chemical. The SBM base chemical usually constitutes about 50% to 90% by volume of the fluid portion of the SBM and about 20% to 40% of the mass of the mud (Neff et al., 2000). The major ingredients are similar for all SBM systems. All SBM systems contain emulsifiers, wetting agents, thinners, weighting agents and gelling agents. Relative proportions of the different ingredients vary depending on the SBM type and the chemistry, geology and depth of the formation being drilled.

In contrast to OBMs composed of diesel or mineral oils that are refined from crude oil, SBMs are all made from compounds that contain none of the toxic components found in refined oils, such as aromatics and cyclic structures.

The most common SBM types include esters, ethers (the most current version, a di-ether, is more biodegradable than its mono-ether predecessor), iso-alkanes, poly-alpha-olefins (PAOs), detergent alkylate, linear alpha-olefins (LAOs), isomerized olefins (IOs), and dimethyl siloxane based oligomeric siloxanes (Hart et al., 2007).

2.3 CONTAMINANTS

SBM base fluids typically contain very low concentrations (less than 0.001%) of polynuclear aromatic hydrocarbons (PAHs), whereas OBMs using diesel or mineral oil typically contain 5% to 10% PAHs in diesel oil and 0.35% PAH in mineral oil (OGP, 2003). The PAHs typically found in diesel and mineral oils include the toxic priority pollutants fluorene, naphthalene, and phenanthrene, and non conventional pollutants such as alkylated benzenes and biphenyls (USEPA, 2000a). In the Gulf of Mexico, current discharge permits (see Section 3) limit the PAH content of SBM base fluids to 10 ppm. The permits also prohibit discharge of formation oil (i.e. oil from the formation co-mingling in SBM returned to surface), which is a contaminant of SBM and an “indicator” pollutant for toxic and priority pollutant components such as benzene, toluene, ethylbenzene, naphthalene, phenanthrene and phenol. In Canada, current discharge guidelines limit the PAH content of SBM base fluids to 10 ppm.

Most metals are present in drilling muds and cuttings at concentrations similar to those in uncontaminated marine sediments (Neff et al., 2000). However, a few metals may be present in some drilling muds at concentrations substantially higher (>100-fold) than natural concentrations in sediments; these include barium, chromium, lead and zinc. Most of the chromium is associated with chrome and ferrochrome lignosulfonates, used frequently in the past as a clay deflocculent in WBMs. The other metals in drilling muds are associated with dispersed cuttings and the solid additives (barite and clays), not the continuous phase (water, oil, or synthetic). Current discharge permits in the Gulf of Mexico limit the cadmium and mercury content of stock barite used in both WBMs and SBMs.

Two of the monitoring programs reviewed in this study included measurements of metals and hydrocarbons in sediments near drill sites, as summarized in Section 3 below.

3.0 REGULATORY STANDARDS AND GUIDELINES

3.1 CURRENT NATIONAL REGULATIONS AND GUIDELINES

The disposal of drill mud and cuttings in Eastern Canada is currently controlled under the Offshore Waste Treatment Guidelines, 2002. These guidelines describe the standards to be followed for the disposal of wastes from petroleum drilling and production operations in Canada’s offshore areas, and the sampling and analysis procedures to be followed to comply with these standards. The guidelines were jointly developed by the National Energy Board, the Canada-Newfoundland Offshore Petroleum Board, and the Canada- Nova Scotia Offshore Petroleum Board (National Energy Board et al., 2002).

For the purposes of drill mud disposal, these guidelines are intended to minimize the amount of hydrocarbons discharged into the marine environment, and to encourage the use of water based mud (WBM) or synthetic-based mud (SBM). Currently, the use of oil-based mud (OBM) in Canada’s offshore areas is only granted approval by the Chief Conservation Officer when it is not technically feasible to use WBM or SBM. This only occurs in exceptional circumstances, and at no time can OBM be discharged to the sea. The Chief Conservation Officer may at times grant approval for the use of enhanced mineral oil-based mud (EMOBM), provided that its environmental and safety performance has been proven to be similar to that of SBM.

However, it is not permitted to discharge whole SBM and EMOBM at sea. Instead, they must be recovered and recycled, re-injected, or transferred to shore to be treated and disposed of using a method approved by the Chief Conservation Officer (National Energy Board et al., 2002). It is permitted to dispose of WBM in Canada's offshore production areas; however, operators are encouraged to have a fluids management plan to reduce the total amount discharged.

Drill cuttings associated with SBM and EMOBM are to be re-injected, and where this option may not be technically feasible, the cuttings may be discharged to sea provided that they are treated first with the best available technology. When these guidelines were published, the best available treatment technology in some regions of the world was believed to be 6.9 g/100 g or less of oil on wet solids (National Energy Board et al., 2002), and 6.9% was set as the allowable discharge limit for synthetic oil on cuttings (SOC). It is important to note that this discharge limit may be modified in individual circumstances where more challenging formations and drilling conditions are experienced or areas of increased environmental risk are identified (National Energy Board et al., 2002). In Nova Scotia, the 6.9% target has been reached through a combination of treatment system technologies and other management controls, such as ship to shore.

3.2 OTHER REGIONS AND JURISDICTIONS

Appendix A provides a general summary of regulations and guidelines pertaining to the disposal of drill mud and cuttings for numerous offshore petroleum production areas around the world. Most of the information in Appendix A is current up to at least 2003 (OGP, 2003). It was not within the scope of this study to verify the current regulatory status of each of these jurisdictions. However, for purposes of reference and context, six of the key areas, including the United States, the North Sea, Australia, Norway and Brazil, have been updated and described in greater detail in the following subsections.

3.2.1 UNITED STATES

Jurisdiction over offshore regions in the United States is governed by a number of acts and dependent, for the most part, on distance from shore. The Submerged Land Act (SLA), passed in 1953, granted individual states jurisdiction over any natural resources within 5.6 kilometres (3.45 miles) off the coastline. In 1953, the Outer Continental Shelf Lands Act (OCSLA) was passed. This act defined the outer continental shelf as separate geographic regions that extended beyond state jurisdiction and fell under federal responsibility (Energy Information Administration, 2005).

In 1983, international boundaries were declared under the U.S. Exclusive Economic Zone (EEZ). The international boundaries gave the United States jurisdiction over all waters extending 370 km (230 miles) from the U.S. coastline. In 1994, all countries were granted the same jurisdiction, under the International Law of the Sea. The United States and the Gulf of Mexico have also signed two treaties since 1978 to assign jurisdiction over overlapping offshore areas (Energy Information Administration, 2005).

All regulations pertaining to environmental issues associated with offshore oil production in the U.S. are administered by the following federal agencies (Energy and Information Administration, 2005):

- Department of the Interior (DOI)
- United States Environmental Protection Agency (USEPA)
- Department of Commerce's National Oceanic and Atmospheric Administration (NOAA), and
- U.S. Fish and Wildlife Service (FWS)

Regulations pertaining to the disposal of WBM, SBM and OBM and drill cuttings are, for the most part, administered by the USEPA. The regulations differ slightly, depending on the jurisdiction. In general, the disposal of OBM and EMOBM and associated cuttings are prohibited in all jurisdictions in the U.S. The discharge of WBM and cuttings in offshore waters is permitted given the following:

- More than 4.8 km (3 miles) from shore (does not apply in Alaskan coastal waters)
- Toxicity limit of LC50 for suspended particulate phase greater than 30,000 mg/kg
- 1 mg/kg limit for mercury and 3 mg/kg limit for cadmium in barite
- No free oil or diesel oil, and
- Discharge rate less than 1,000 bbl/hr

The regulations pertaining to the discharge of SBM and cuttings differ, depending on the area. In the Gulf of Mexico, the discharge of SBM is permitted subject to limits relative to distance from shore, mud retention on cuttings, toxicity, mercury and cadmium in barite, and the presence of free and diesel oil. Details are provided in Appendix A. In California, discharges of SBM and cuttings are not permitted. Discharges are permitted in Alaska waters subject to the same limits as the western Gulf of Mexico, except for the coastal Cook Inlet. Further details are provided below for the Gulf of Mexico.

3.2.1.1 GULF OF MEXICO

Disposal of drill mud and cuttings in the Gulf of Mexico is regulated by the USEPA through permits issued under the National Pollutant Discharge Elimination System (NPDES) (CSA International Inc., 2008). For regulation purposes, the Outer Continental Shelf of the Gulf of Mexico is divided into two regions. These regions, and associated permits, consist of the following:

- Region 6 – Includes the western Gulf and most of the central Gulf and is regulated under NPDES permit GMG290000.
- Region 4 – Includes the eastern Gulf and parts of the central Gulf and is regulated under NPDES permit GMG460000.

The limitations on the disposal of drill mud and cuttings specified in the two permits are essentially identical. WBM and associated cuttings may be discharged, subject to limits on free oil, cadmium and mercury in stock barite, toxicity of the suspended particulate phase, and drilling mud discharge rate. The eastern Gulf permit also prohibits discharges within 1,000 metres of Areas of Biological Concern and ocean disposal sites. The central and western Gulf permit prohibits discharges within Areas of Biological Concern and controls the drilling mud discharge rate within 544 metres of these areas.

SBMs may not be discharged, except for small amounts adhering to cuttings and certain small volume discharges. SBM cuttings discharges are allowed, subject to several limitations. They must meet the same limits as WBMs and cuttings for free oil, cadmium and mercury in stock barite, and toxicity of the suspended particulate phase. The stock fluid must meet limits for polynuclear aromatic hydrocarbon (PAH) content, sediment toxicity, and biodegradation rate. In addition, the discharged material is subject to limits on sediment toxicity, base fluid retention on cuttings (6.9% for internal olefins and 9.4% for esters), and formation oil.

OBMs, inverse emulsion muds, oil contaminated muds, and muds to which any diesel oil has been added cannot be discharged. Mineral oil may be used only as a carrier fluid (transporter fluid), lubricity additive, or pill in water based drilling muds and may be discharged with those drilling muds, provided the discharge continues to meet the no free oil and toxicity limits, and the pill is removed prior to discharge.

The permit for Region 4 is scheduled to expire at the end of December in 2009 and for Region 6 in September of 2012. Currently, the regulations pertaining to the disposal of drill muds and cuttings are not expected to change when these permits are renewed.

Effluent limits for drilling muds and cuttings discharges on the U.S. Gulf of Mexico Outer Continental Shelf based on USEPA permits GMG290000 (central and western Gulf of Mexico) and GMG460000 (eastern Gulf of Mexico) are presented in Table 3.1.

TABLE 3.1 DRILL MUD AND CUTTINGS EFFLUENT DISCHARGE LIMITS
ON THE U.S. GULF OF MEXICO OUTER CONTINENTAL SHELF

Regulated Parameter	Discharge Limitation/Provision
Water-based Drilling Muds and Cuttings	
Drilling mud toxicity	30,000 ppm (daily minimum and a monthly average minimum) (96 h LC50 of suspended particulate phase with <i>Mysidopsis bahia</i>)
Cadmium in stock barite	3.0 mg/kg (dry wt)
Mercury in stock barite	1.0 mg/kg (dry wt)
Free oil	No discharge (static sheen test)
Discharge rate	1,000 bbl/h maximum (does not apply to drilling muds discharged prior to installation of the marine riser)
Discharges near Areas of Biological Concern	Eastern Gulf of Mexico: No discharge of drilling muds and cuttings from facilities within 1,000 m of an Area of Biological Concern Central and Western Gulf of Mexico: No discharge of drilling muds within Areas of Biological Concern. Drilling mud discharge rate within 544 m of Areas of Biological Concern is limited based on distance and mud toxicity.
Discharges near ocean disposal sites	Eastern Gulf of Mexico: No discharge within 1,000 m of a Federally Designated Dredged Material Ocean Disposal Site
Synthetic-based Muds (SBMs)	
Discharges	No discharge, except that which adheres to cuttings, small volume discharges, and de minimis discharges. Small volume discharges include displaced interfaces, accumulated solids in sand traps, pit clean-out solids, and centrifuge discharges made while changing mud weight. Allowable de minimis discharges include wind blown muds from the pipe rack and minor drips and splatters around mud handling and solids control equipment
SBM Cuttings	
Drilling mud toxicity	30,000 ppm (daily minimum and a monthly average minimum) (96 h LC 50 of suspended particulate phase using <i>Mysidopsis bahia</i>)
Cadmium in stock barite	3.0 mg/kg (dry wt)
Mercury in stock barite	1.0 mg/kg (dry wt)
Free oil	No discharge (static sheen test)
Formation oil	No discharge
Polynuclear aromatic hydrocarbon (PAH) content of stock fluid	10 ppm PAH (as phenanthrene) in base fluid
Sediment toxicity of stock fluid	10-day LC50 from sediment toxicity test of the base fluid with <i>Leptocheirus plumulosus</i> must not be less than the 10-day LC50 of the internal olefin or ester reference fluid.
Biodegradation rate of stock fluid	Cumulative gas production of stock base fluid at 275 days must not be higher than that of the internal olefin or ester reference fluid.
Base fluid retention on cuttings: C16-C18 internal olefin	6.9 g/100 g of wet drill cuttings (end-of-well maximum weighted mass ratio averaged over all well sections)
Base fluid retention on cuttings: C12-C14 ester or C8 ester	9.4 g/100 g of wet drill cuttings (end-of-well maximum weighted mass ratio averaged over all well sections)

Regulated Parameter	Discharge Limitation/Provision
SBM Cuttings	
Sediment toxicity ratio of discharged drilling muds	4-day LC50 of sample removed from solids control equipment must not be less than that of the internal olefin or ester reference drilling mud
Other Non-aqueous Drilling Muds	
Oil-based drilling muds	No discharge of drilling muds or associated cuttings
Oil-contaminated drilling muds	No discharge of drilling muds or associated cuttings
Drilling muds to which diesel oil has been added	No discharge of drilling muds or associated cuttings
Mineral oil	Mineral oil may be used only as a carrier fluid, lubricity additive, or pill. Discharge allowed if it meets the limitations for toxicity and free oil

3.2.2 RATIONALE FOR GULF OF MEXICO LIMITATIONS

The development document prepared by USEPA (2000a) for the SBM effluent guidelines provides the rationale for these requirements. The overall strategy was to use stock limitations and discharge limitations in a two part approach to control these discharges. The objective in the first part is to control which SBMs are allowed for discharge through the use of stock limitations (e.g., sediment toxicity, biodegradation, PAH content, metals content) and discharge limitations (e.g., free oil prohibition, formation oil prohibition, sediment toxicity, aqueous toxicity). The objective in the second part is to control the quantity of SBM discharged with SBM cuttings. Key aspects of the SBM cuttings limitations are discussed briefly below.

FORMATION OIL

Permits issued by the USEPA prohibit discharge of formation oil. Formation oil is a contaminant returned to the surface in the drill cuttings from the geological formation. Formation oil is an “indicator” pollutant for toxic and priority pollutant components such as aromatic hydrocarbons and PAHs. These pollutants include benzene, toluene, ethylbenzene, naphthalene, phenanthrene and phenol. Monitoring for formation oil in the drilling muds is required once prior to drilling (or by certification from the supplier) and once per week during drilling.

PAH CONTENT

The PAH content of base fluids is regulated because PAHs consist of toxic priority pollutants. The limit (10 ppm) helps discriminate between acceptable and non-acceptable base fluids. SBM base fluids typically do not contain PAHs, whereas oil based muds comprising diesel or mineral oil typically contain 5% to 10% PAH in diesel oil and 0.35% PAH in mineral oil. The PAHs typically found in diesel and mineral oils include the toxic priority pollutants fluorene, naphthalene and phenanthrene, and non conventional pollutants such as alkylated benzenes and biphenyls (USEPA, 2000a).

SEDIMENT TOXICITY

For both WBMs and SBMs, 96 hour suspended particulate phase bioassays are required with the mysid shrimp, *Mysidopsis bahia*. In addition, for SBMs, sediment toxicity tests are required with the amphipod *Leptocheirus plumulosus*. Sediment toxicity tests were added because the suspended particulate phase bioassay is highly variable when applied to SBMs and does not seem to give meaningful results (USEPA, 2000b).

For the stock fluid, a 10 day sediment toxicity test is conducted, and the LC50 must not exceed the value obtained with an internal olefin or ester reference fluid. This test is done at least once per year on each fluid blend. For drilling mud samples, which are tested once per month per well, a 4 day sediment toxicity test is conducted, and again the LC50 must not exceed that of the reference fluid.

BIODEGRADATION RATE

A measure of biodegradation rate was included because organic enrichment is a dominant impact of SBM cuttings discharges and biodegradability is an important factor in assessing their fate and effects (USEPA, 2000a). The USEPA specifies a test method for evaluating the anaerobic biodegradability of the stock fluid by measuring biogas production over a period of 275 days. The cumulative gas production of the stock fluid must not be higher than that of an internal olefin or ester reference fluid (IBID).

RETENTION ON CUTTINGS

The limits for drilling mud retention on cuttings are 6.9% for internal olefins and 9.4% for esters. These are averages over all SBM well sections. Operators are required to monitor %SOC, or sometimes referred to as retention on cuttings (ROC), by taking grab samples at the solids control equipment once per day, or one sample for every 500 feet drilled (up to three per day). When seafloor discharges are made during dual gradient drilling, ROC cannot be monitored and the USEPA specifies default values of 14% of base fluid retained on cuttings and 15% as the mass fraction of cuttings discharged at the seafloor. The default values are to be averaged with results from daily monitoring to determine compliance.

The ROC limits were developed by the USEPA based on a statistical analysis of data from 65 wells and representing four cuttings dryer technologies (vertical and horizontal centrifuges, squeeze presses and High-G linear shakers) (USEPA, 2000c). The upper 95th percentile of the ROC data was used to set the ROC limits. The numeric limit was calculated to manage two treatment conditions, one was based on 97% of the cuttings volume discharged from the cuttings dryer technology and 3% of the cuttings volume discharged from the fines removal technology (such as centrifuges). The second condition was based on 100% of material processed using a single-type cuttings dryer technology (USEPA, 2000b). The USEPA also noted that the well average retention on cuttings measurements from Canada were all higher than those found in the Gulf of Mexico, arguing that the Canadian data does not belong to the same probability distribution as that associated with the data from the Gulf of Mexico. USEPA concluded that because these technologies appear physically and statistically different, a single distribution for retention on cuttings from any combination of cuttings dryer technologies does not exist for multiple regions (USEPA 2000b). The difference in ROC appears to be associated with variation/differences in geological formations (coarser materials generally associated with the Gulf of Mexico), and differences in the well

bottom hole assemblies, all resulting in higher %SOC in the Canadian offshore wells. One operator reported that drilling operations conducted in the Nova Scotia offshore in 2002 were able to achieve the 6.9%SOC through use of a Verti G™ cuttings dryer, combined with ship-to-shore transport of some drilling wastes. However, the provided data could not be used to assess the Verti G™ cuttings dryer stand alone performance.

The USEPA provide a more flexible regulatory framework in the Gulf for cuttings than those currently in place in some Canadian jurisdictions. Key differences are summarized as follows:

- Best Management Practices (BMP) Alternative: The permits allow operators (in conjunction with drilling contractors) to design and implement a BMP Plan to help reduce ROC monitoring. The ROC limits are not changed, but the operator is only required to monitor the first third of the SBM well interval if the permit's ROC limits are met. Essentially, once operators demonstrate compliance with the performance-based measurement, operators continue to use BMPs and may discontinue SBM cuttings monitoring (Johnston et al., 2004).
- Canada measures ROC cuttings compliance based on data evaluated on a 48 hour rolling average (described below); conversely, USEPA permits specify cuttings discharge data evaluation intervals (e.g., sampling every 500 metres drilled, one sample per day, etc). However, operators report end-of-well maximum weighted mass ratio averaged over all well sections. For the Gulf of Mexico, in instances where well interval sections exceed 6.9% SOC, the operators will sometimes use ship-to-shore to dispose of fines developed from the well bottom. Thus, when calculating the overall end-of-well %SOC, the 0% SOC mass is permitted in the gross calculation, which effectively reduces the overall %SOC reported.

According to USEPA (2000a), limiting the SBM content of discharged cuttings was intended to control: (1) the amount of SBM discharged into the ocean; (2) the biodegradation rate effects of discharged SBM; and (3) the potential for SBM cuttings to develop cuttings piles and mats.

3.2.3 NORWAY

Oil exploration in Norway occurs primarily along the Norwegian Continental Shelf. This includes the areas where Norway exercises rights for economic development under the United Nations Convention on the Law of the Sea and includes the North Sea, the Norwegian Sea and a portion of the Barents Sea. The key legislation that pertains to the disposal of drill muds and cuttings in Norway includes the following (Oil and Gas UK Environmental Legislation, 2008):

- Offshore Chemical Regulations, 2002;
- Offshore Petroleum Activities Regulations, 2005;
- Food and Environment Protection Act, 1985;
- Convention on the Protection of the Marine Environment of the North East Atlantic (OSPAR); and
- OSPAR Decision 2000/3 on the Use of Organic-Phase Drilling Fluids (OPF) and the Discharge of OPF-Contaminated Cuttings.
- In Norway the above legislation pertaining to the disposal of drilling muds and cuttings is regulated by the Norwegian State Pollution Control Authority (SFT) through the use of discharge permits (Wills,

J., 2000). In general, the following limitations apply to the disposal of drilling muds and cuttings along the Norwegian Continental Shelf (including the North Sea and the Norwegian Sea):

- At present, it is legal to discharge WBM cuttings in the offshore waters of the OSPAR signatory countries, provided the oil content is less than 1% by weight and the material has passed tests to show that it will bio-degrade over a specified time and will not bioaccumulate (See further details below for “North Sea”). However, the UK 2005 Offshore Petroleum Activities (Oil Pollution Prevention and Control) Regulations introduced a permit issuing system for the discharge of WBM cuttings contaminated with reservoir crude with no threshold concentrations for oil retention. OBM are not permitted to be discharged and instead are re-injected or taken to shore for disposal.
- SBMs are evaluated in a similar way as water-based muds and granted a permit for disposal dependent on the results; however the discharge of SBM north of the 62nd parallel (north of the North Sea) is not permitted (Will J., 2000).
- The disposal of drill cuttings, including cuttings contaminated with either WBM, OBM or SBM, is granted a discharge permit if they contain less than 1% oil on cuttings (Will, J., 2000).

The above limitations do not apply to the Norwegian section of the Barents Sea, where instead they have adopted a zero discharge policy (Dahle S., Camus L., 2007).

3.2.4 NORTH SEA

The Offshore Chemical Notification Scheme (OCNS) manages chemical use and discharge by the UK and Netherlands offshore petroleum industries. The OCNS was originally introduced by the UK in 1979. In 1993, the UK Government introduced a revised scheme, which classified chemicals using test protocols approved by the Oslo and Paris Commissions (OSPAR). This was modified in detail in early 1996 to meet the requirements of the OSPAR Harmonised Offshore Chemical Notification Format (HOCNF), which co-ordinates the testing requirements for oilfield chemicals throughout the NE Atlantic sector.

The OCNS uses the OSPAR Harmonized Mandatory Control Scheme (HMCS), developed through the OSPAR Decision 2000/2, on a system for the use and discharge of offshore chemicals (as amended by OSPAR Decision 2005/1) and its supporting recommendations. This ranks chemical products according to Hazard Quotient (HQ), calculated using the CHARM (Chemical Hazard and Risk Management) model.

The main driver for reductions in oily discharges into the North Sea is the OSPAR Convention. The OSPAR Convention serves as the basis for national laws governing discharge of drilling wastes in offshore waters of the oil producing coastal states of Western Europe (Wills, J., 2000). As stated above, the discharge of WBM into the North Sea is permitted given that the oil content is less than 1% by weight and that it has passed toxicity testing. The OSPAR Decision 2000/3, 2001, virtually eliminated the discharge of OBM and SBM or cuttings contaminated with these muds. Cut-off values for the selection criteria of the OSPAR dynamic selection and prioritization mechanism for hazardous substances (OSPAR Commission, 2002: Dynamic Selection and Prioritisation Mechanism for Hazardous Substances – new DYNAMEC manual) are as follows:

The intrinsic properties of individual substances, specifically whether they are persistent (P), toxic (T) or liable to bioaccumulate (B), determine whether they fall within the definition of hazardous substances given in the

OSPAR Strategy with regard to Hazardous Substances. These three intrinsic properties (PTB criteria) have been used, along with cut-off values for each, as the criteria for selecting substances in the Initial Selection Procedure of the Dynamic Selection and Prioritization Mechanism. The criteria are also used for selection of new substances, as well as for deselecting substances. The cut-off values for each of these criteria are as follows:

- Persistency (P): Half-life ($T_{1/2}$) of 50 days
- Liability to Bioaccumulate (B): log octanol-water partition co-effective (K_{ow}) ≥ 4 or bioconcentration factor (BCF) ≥ 500
- Toxicity (T): acute $L(E)C_{50} = < 1$ mg/l, long-term NOEC = < 0.1 mg/l

This selection is a combination of the least stringent criteria considered during the development of the Initial Selection Procedure. For aquatic toxicity, mammalian toxicity is added as well as the criteria for the aquatic environment. For bio accumulation, the selected cut-off value is the same as that proposed for international classification and labelling. The process for and the results of the OECD Global Harmonisation of Classification Criteria can be found on the Internet at <http://www.oecd.org/ehs/Class/HCL6.htm>.

3.2.5 AUSTRALIA

Legislation pertaining to the discharge of drilling waste in Australia is regulated by the Department of Industry and Resources (DoIR). All drilling proposals where the use of drilling mud is required are to include an Environmental Management Plan (EMP). The assessment approach of the EMP takes into account the technical rationale for the proposed mud and its environmental performance (includes toxicity, bioaccumulation and biodegradation), the environmental sensitivities of the drilling location and the method for disposal (Environment Division, 2006).

The use of OBM with aromatics greater than 1% in Australia is not permitted because of the potential for environmental effects. Disposal of OBM (aromatics $< 1\%$) on cuttings is limited to 1% retention on cuttings.

Where the use of SBM is accepted, discharges to the seabed are limited to a maximum amount of 10% by dry weight of base fluid on drilled cuttings for a 311 mm (12 1/4 inch) hole size. It should be noted that a 10% dry weight ROC will equate to a lower value wet % and could be as low as 6.9 %, depending on the oil-water ratio of the drilling fluid.

Currently in Western Australia, over 80% of all wells are drilled using WBM in all hole sections. The remaining wells are drilled using WBM for the top hole sections and non-WBMs in the 311 mm (12 1/4 inch) and/or 216 mm (8 1/2 inch) bottom hole sections. The use of low toxicity OBMs in the bottom hole sections has been reduced from 10% of all wells drilled in 1994 to 0% (as of mid-1998). The use of SBMs has remained essentially the same over the same period with increasing proportion of ester based fluids (EBFs). Since the late 1980s, there has been a trend towards the increased use of more technically advanced WBMs.

Operators have discharged cuttings generated using SBMs containing esters, internal olefins (IOs), ester/IO blends, and ester/IO/ linear alpha olefin (LAO) blends. Requirements for monitoring programs are determined on case by case basis. Paraffin based fluid cuttings have also been discharged in Western Australia.

3.2.6 BRAZIL

For the most part, the discharge of drill muds and cuttings in Brazil is regulated through the Brazilian Institute of Environment and Renewable Natural Resources (IBAMA). All drilling discharge plans need to be approved through IBAMA; IBAMA has made it clear that there will be greater scrutiny of non-aqueous fluid discharges (than those of water based fluids), while OBM is not permitted for discharge. It is also unlikely that low toxicity mineral oils would be approved; however, enhanced mineral oil based fluids are possible.

An industry work group formulated the following guidelines for discharge approval (laboratory testing protocols- biodegradability, sediment toxicity and bioaccumulation) and worked with government to develop a framework for gaining approval for the use of synthetics.

- + Zero discharge in <60 m water depth and environmentally sensitive areas;
- + Non-aqueous drilling fluid (SBM) cuttings permitted for discharge into water depths >60 m subject to pre and post drill toxicity tests on organisms from four different phyla and lab tests of SBM for biodegradation (OECD 306 method), total PAH concentration and bioaccumulation potential (log Pow);
- + Average <9.4%ROC for ester, average <6.9%ROC for paraffin/olefin;
- + < 1mg/kg mercury and < 3 mg/kg cadmium in barite;
- + <1% formation oil;
- + Monitoring requirements that vary by depth;
- + >1,000 m: no monitoring required;
- + 60–1,000 m: comprehensive water column and seabed monitoring

3.3 MEASURING SBM AND CUTTINGS COMPLIANCE

SBMs were first used in the Gulf of Mexico in June 1992 (USEPA, 2000a). In 1993, USEPA published effluent guidelines for drilling muds and cuttings that included mercury and cadmium limitations on the stock barite, a diesel oil discharge prohibition, a toxicity limitation on the suspended particulate phase (SPP) generated when the drilling muds or cuttings are mixed in seawater, and no discharge of free oil as determined by the static sheen test. At the time, the USEPA allowed discharges of SBM cuttings in the western and central Gulf of Mexico without any special conditions. The USEPA believed that all drilling muds, including SBMs, could be controlled by the SPP toxicity and static sheen tests (USEPA, 2000a).

Subsequent research in the U.S indicated that regulations were needed for SBM cuttings because of differences in the fate and effects of these cuttings (USEPA, 2000a). Problems included the following: (1) the SPP toxicity test may not accurately represent the toxicity of SBMs because they adhere more tightly to cuttings; (2) SBM cuttings have the potential to create anoxia as the base fluid decomposes in seafloor sediments; and (3) there were problems in interpreting the static sheen test as it applies to SBMs.

Effluent limits in the U.S. were developed for SBM cuttings in 1999–2000 (USEPA, 2000a) and were incorporated as modifications to the existing National Pollutant Discharge Elimination System (NPDES) permit for the western and central Gulf of Mexico in 2001 (effective February 2002). No changes were made at that time

to the existing eastern Gulf of Mexico general permit, which did not allow SBM cuttings discharges (as a result of stricter requirements prohibiting discharges within 1,000 metres of areas of biological concern such as the extensive sponge/coral “live bottom” areas that occur on the west Florida shelf).

The current general permits in the U.S. incorporating the SBM effluent limits were issued in 2004 (eastern Gulf) and 2007 (western and central Gulf).

Two other USEPA regions currently issue or review permits for drilling discharges: Region 9 for offshore California and Region 10 for offshore Alaska and Cook Inlet, Alaska. Permits in Regions 9 and 10 have never allowed the discharge of SBMs. Any discharge of SBMs would require an individual permit or a modification of the general permits.

As discussed in Section 3.1, discharge guidelines for SBM drill cuttings in Eastern Canada are based on best available technology. This guideline evolved from the Gulf of Mexico guidelines, as discussed in Section 3.2.3. However additional limitations pertaining to the Gulf of Mexico include limitations on discharge distance from shore, toxicity, mercury and cadmium in barite, and the presence of free and diesel oil. It is important to note that base fluid retention on cuttings limitations are applicable to the end-of-well maximum weighted mass ratio averaged over all SBM well sections.

In Canadian offshore waters, the concentration of oil on drill solids is measured every 12 hours using the Procedure for Field Testing of Oil Based Drilling Muds and a 48-hour rolling average in grams per 100 grams of wet solids is calculated. According to personal communications with CNSOPB, there have been no reported exceedances of the OWTG Guidelines pertaining to discharge of mud and cuttings since they came into effect in Sept. 2002 (Pers.Comm. C NSOPB).

The Offshore Waste Treatment Guideline specifies a schedule for toxicity testing for all generic muds (both WBM and SBM), mostly for monitoring purposes. The Offshore Waste Treatment Guidelines also specify toxicity testing for the following (National Energy Board et al., 2002):

- When applying for authority to drill a well, each operator must identify potential drilling muds to be used in each section of the well and provide toxicity results, using Environment Canada’s test method EPS 1/RM/26 (Biological Test Method, Acute Test for Sediment Toxicity using Marine Amphipods); and
- The base fluid of the proposed drilling mud must be proven non-toxic using the Laboratory Procedure for Determining the Acute Lethality of the Water Soluble Fraction of Mineral Oil to Rainbow Trout.

The Gulf of Mexico toxicity limitations use sediment toxicity tests (Dorn et al., 2007). In 2003, the USEPA issued a memo recommending that the NPDES permit writers reject any changes to the biodegradation limitations and to the technology based sediment toxicity standards in any future permitting actions. With the move from WBM to SBMs, a sediment toxicity test was developed by the USEPA to be used as a discharge limitation, because SBMs have a tendency to attach to cuttings and settle in the sediment, instead of being suspended in the water column like WBM. In 2007, Dorn et al. published a report assessing the development of this method and efforts made by the industry to understand and limit the variability of the new test. The purposes of the report were to represent a continual effort to evaluate and improve the performance of the sediment toxicity test, raise confidence in the test and reduce the occurrence of false negatives.

During the development of the new test in the U.S., various sediment toxicity tests were reviewed by a subgroup of the Synthetic Based Mud Research Group. After review, four sediment toxicity tests were identified for laboratory trials. After completion of the laboratory trials, a screening study by the group, the USEPA, and its contractor recommended the 10-day aquatic sediment toxicity test using the marine amphipod, *Leptocheirus plumulosus* (Dorn et al., 2007). The 96-hour test was later recommended by the USEPA over the longer term test, and it was accepted. After development of the test, two inter laboratory investigations were conducted where various field muds were tested against reference muds. Results showed significant differences in toxicity results from laboratory to laboratory for field mud samples and also between field and reference mud samples in the same laboratory.

The paper concluded that a high degree of variability still existed within the test even when carefully controlled in a laboratory setting. The authors noted that the level of test variability was unacceptable and unsustainable for compliance with legal limits. However, the USEPA promoted the approach anyway.

Most of the technology-based limitations pertaining to the disposal of SBM on cuttings around the world have to do with percent retention of mud on cuttings. As noted above, the Gulf of Mexico has additional limitations, including toxicity testing and biodegradation. Australia has added a limitation stipulating the size of the drill hole for which SBM may be discharged. Other countries, including Norway, have prescribed environmental monitoring programs as a means of measuring treatment performance (See Appendix A).

3.4 FURTHER INFORMATION ABOUT BEST MANAGEMENT PRACTICES

In the Gulf of Mexico, a BMP approach is permitted that essentially requires the operator to devise a program to keep better track of SBM at all stages of handling. Examples include establishing operations and maintenance procedures for each component in the solids control system, identifying and quickly repairing malfunctioning equipment, establishing mud pit and equipment cleaning methods to minimize the potential for cuttings buildup, and using the most appropriate spacers, flushes, pills and displacement techniques when changing mud systems. The following specific pollution prevention activities are required in a BMP approach (Johnston et al., 2004):

- 1) Establishing programs for identifying, documenting and repairing malfunctioning SBM equipment, tracking SBM equipment repairs, and training personnel to report and evaluate malfunctioning SBM equipment;
- 2) Establishing operating and maintenance procedures for each component in the solids control system in a manner consistent with the manufacturer's design criteria;
- 3) Using the most applicable spacers, flushes, pills and displacement techniques to minimize contamination of drilling fluids when changing from water-based drilling fluids to SBMs and vice versa;
- 4) Monitoring SBM cuttings for the first third of the SBM well interval to demonstrate compliance with the end-of-well permit limitation. Additional monitoring is required for the second (and final third, if necessary) if the SBM well interval ROC value is not below the permit limitation. The operator will re evaluate and modify the BMP Plan in conjunction with equipment vendors and/or industry specialists if the ROC value for the entire well is not below the permit limitation;
- 5) Including SBM cuttings monitoring data for discharges managed by BMPs in their NPDES permit reports;
- 6) Establishing mud pit and equipment cleaning methods in such a way as to minimize the potential

for building up drill cuttings (including accumulated solids) in the active mud system and solids control equipment system. These cleaning methods shall include but are not limited to ensuring proper operation and efficiency of mud pit agitation equipment; using mud gun lines during mixing operations to provide agitation in dead spaces; and pumping drilling fluids off of drill cuttings (including accumulated solids) for use, recycling, or disposal before using wash water to dislodge solids.

The BMP compliance option also includes information collection requirements. Examples include (1) training personnel; (2) analyzing spills that occur; (3) identifying equipment items that may need to be maintained, upgraded or repaired; (4) identifying procedures for waste minimization; (5) performing monitoring (including the operation of monitoring systems) to establish equivalence with a numeric cuttings retention limitation and to detect leaks, spills and intentional diversion; and (6) generally to periodically evaluate the effectiveness of the BMP alternatives.

Johnston et al. (2004) showed that implementation of BMPs in Gulf of Mexico drilling programs significantly reduced SBM retention on cuttings. Using data for comparable well intervals from 72 non BMP wells and 12 BMP wells, retention was reduced from 4.30% (Std.Dev. 1.18%) to 3.53% (Std.Dev. 0.96%). This approach offers an incremental reduction, but obviously is not likely to reduce retention to meet the 1% OSPAR limit.

4.0 DRILL CUTTINGS TREATMENT TECHNOLOGY

Figure 4.1.

Circulation of Drilling Fluid During Drilling and Suspension and Removal of Drill cuttings.(OGP, 2003)

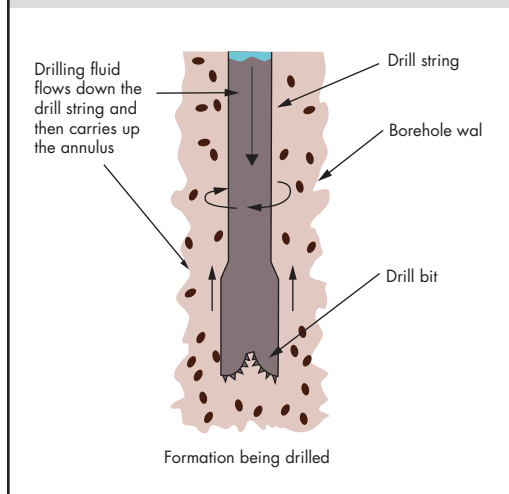

4.1 TREATMENT TECHNOLOGY OVERVIEW

Oil and gas exploration and development drilling operations require the use of drilling fluids (or drilling muds) as the drill bit is advanced to the desired depth. Drilling fluids are complex mixtures of chemicals and solids that are used to remove the drill cuttings from the hole, cool and lubricate the drill bit, maintain hydrostatic pressure on the formation and stabilize the borehole wall.

As shown in Figure 4.1, the drilling fluid is pumped down through the drill string and injected under high pressure through nozzles at the drill bit. As the drill bit rotates and advances into the formation, the small pieces of rock that are broken off are called drill cuttings (refer to Figure 4.2). The drilling fluid then flushes the drill cuttings from the borehole along the annulus between the drill string and borehole wall.

On the drilling platform, the mixture of drilling fluid and cuttings are collected for treatment to control solids and recycle the drilling fluid back down the hole. The use of drilling fluids and the associated treatment and fluid circulating systems are critical components in the overall drilling operations.

The treatment system (or solids-control system) on the drilling platform serves multiple functions as described in the following excerpt from a solids-control equipment and service provider catalogue: “The goal of all modern solids-control systems is to reduce overall well costs through the efficient removal of drilled solids while reducing and minimizing the loss of drill fluids. Additional goals include worker health and safety and environmental compliance.” (MI-SWACO, 2008)

Figure 4.2.
Photograph of Drill Cuttings
(UKOOA website)



Figure 4.3.

Schematic Flow Chart Showing Separation of Drill Cuttings from Drilling Fluids and Options for Cuttings Disposal (OGP, 2003)

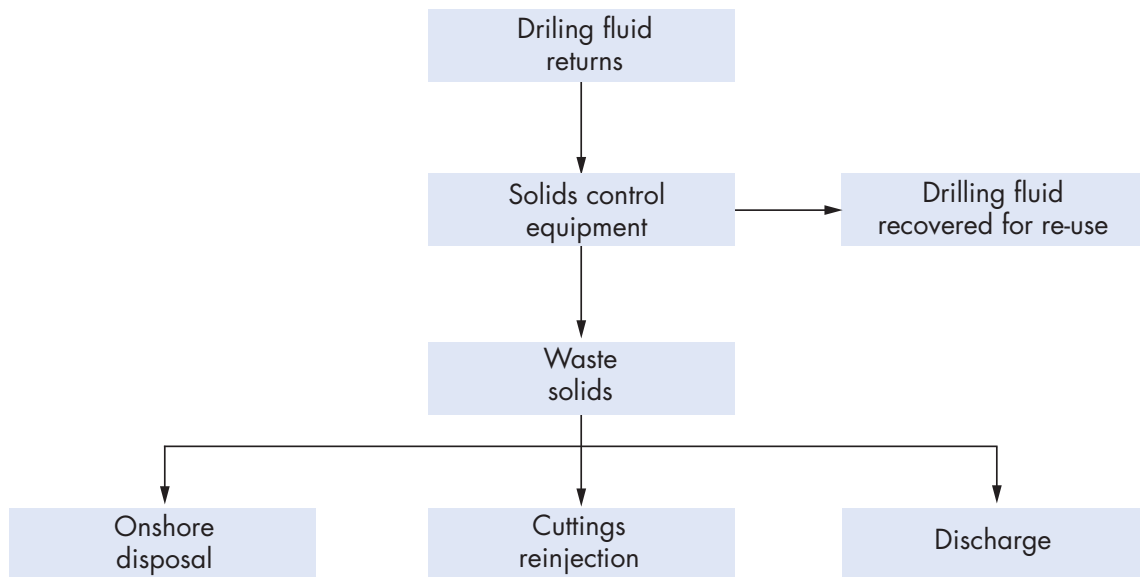

In summary, the primary function of a typical solids-control treatment system is to efficiently remove the solids from the treatment stream in order to maximize the recovery and recycling of the costly drilling fluids. The two objectives are complementary since maximizing the recovery of drilling fluids reduces the fluid retention on cuttings (ROC). In addition, maximizing the recycling of drilling fluid also reduces the total volume of spent SBM drill fluids that must be disposed of upon completion of drilling operations.

Since the 2002 OWTG, stricter environmental compliance requirements have prompted improvements in technologies to reduce ROC. This has included the development of specialized technologies for offshore application, such as “cuttings dryers” and “hammermill” thermal desorption treatment systems (MI-SWACO, 2008).

As detailed in Section 3, the Offshore Waste Treatment Guidelines (August 2002) state that solids may be discharged at the drill site provided they are treated prior to discharge with “best available treatment technology”. The Guidelines also state that the best available technology in some regions of the world has been able to achieve an ROC of 6.9 g/100 g or less oil on wet solids for SBM drill cuttings discharge.

SBM drill cuttings and solids recovered from offshore solids-control systems are commonly disposed of through the use of three potential options:

- 1) Offshore Disposal: Drill cuttings that meet the local regulatory compliance requirements are directly discharged offshore.
- 2) Offshore Reinjection: Drill cuttings are ground to a fine grain size and mixed as a slurry for injection into the local, subsurface geological formation.
- 3) Onshore Disposal: Drill cuttings are transported to shore for subsequent treatment and/or disposal based on local regulatory compliance requirements.

A detailed discussion of the issues and framework for evaluating the various disposal options is provided in the CAPP (2001) report, and later modified in the OGP (2003) report. The key parameters identified in these reports for evaluating drill cuttings disposal options are summarized in Table 4.1

Table 4.1.

Framework of Parameters for Evaluating Disposal Options (OGP, 2003)

Economic	Operational	Environmental
<ul style="list-style-type: none"> • Immediate costs • \$/m³ for disposal • Energy cost • Maintenance cost • Labour cost • Equipment cost • Transportation costs • Disposal costs of end products • Future liabilities 	<ul style="list-style-type: none"> • Safety • Human health issues/chemical exposure* • Processing rate • Mechanical reliability • Size and portability or unit(s) • Space availability • Energy requirements • Condition of end products • Method or disposal after processing • Weather conditions • Availability of appropriate facilities/infrastructure 	<ul style="list-style-type: none"> • Air emissions from drilling and supporting operations • Power requirements • Reduction in volume of waste • By-products of process • Compliance with regulations • Receiving physical environment • Marine species potentially at risk • Potential environmental stressors • Removal of hydrocarbons from solids and water • Environmental issues at onshore site including potential impact to ground and surface water

Section 4.2 provides a detailed review of current and emerging technologies available for offshore treatment of SBM drill cuttings. This section has been subdivided into “primary” and “secondary” treatment systems (OGP, 2003). Primary treatment systems are intended for solids removal and drill fluids recovery, as well as meeting environmental compliance requirements. Secondary treatment systems are additional equipment that may or may not be added to increase drilling fluid recovery and/or help meet stringent regulatory compliance requirements for offshore cuttings discharge.

Offshore reinjection and onshore disposal of drill cuttings are discussed in Section 4.4.

4.2 DRILLING PLATFORM SOLIDS-CONTROL SYSTEMS

4.2.1 PRIMARY TREATMENT SYSTEMS

The solids-control equipment selected for a well drilling program depends on the drilling fluids used, formation characteristics, equipment available on the rig and the specific cuttings disposal requirements. The systems encompass a series of physical separation equipment designed to sequentially remove coarse to very fine grained solids (refer to Figure 4.4).

Commonly used primary solids-control equipment includes shakers, hydrocyclones (such as desanders and desilters) and centrifuges. Drill rigs employ numerous potential configurations of some or all of these various pieces of equipment, depending on the specific solids-control and treatment requirements for the well. In addition,

Figure 4.4.

Solids-Control Equipment Optimum Particle Size Cut Points (Marinescu et al., 2007)

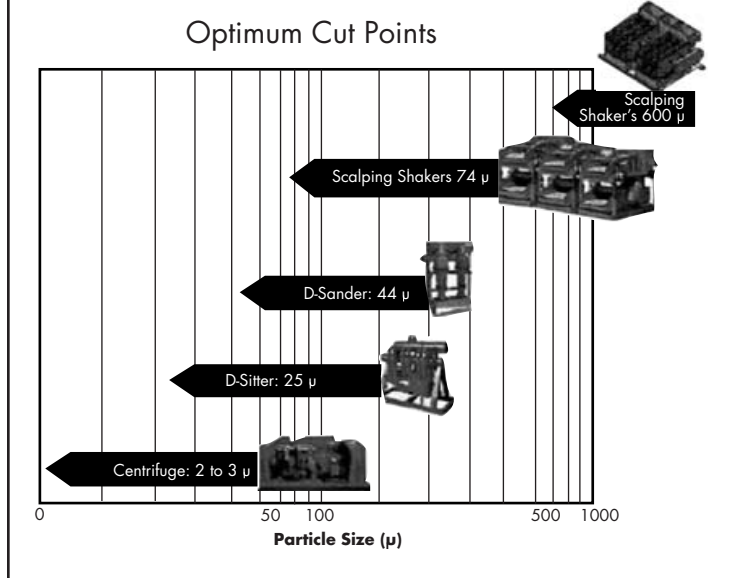

the systems typically include the ability to bypass specific pieces of equipment in the treatment train if required during drilling operations. As a result, there is no one specific treatment process that can be defined for all primary solids-control applications. The system components are selected in number and type based on the site specific drilling requirements, and brought online or offline during drilling operations as required.

The following sections provide descriptions of the various key equipment components that can typically comprise a primary solids-control treatment system for offshore applications.

4.2.1.1 SHAKERS

Shakers (or “shale shakers”) are the primary solids control devices for drill cuttings (OGP, 2003). Drilling fluids and drill cuttings from the borehole are routed to the shaker(s) for removal of coarse grained cuttings (Figure 4.5). The shaker consists of a series of screens that vibrate in horizontal or elliptical motion. As shown in Figure 4.6, at the feed end of the shaker the material is collected in a box (or “possum belly”) where the liquids and solids are evenly disbursed across the vibrating screens. The movement of the vibrating screens is designed to transport the oversize solids (drill cuttings) to the discharge end of the shaker, where they are collected and either transported for secondary treatment (refer to Section 4.2.2) or discharged directly as per the final disposal method.

Figure 4.5.

Example of Shaker Equipment (MI-SWACO, 2008)



Figure 4.6.
Typical Shaker Screening
Operation (CAPP, 2001)

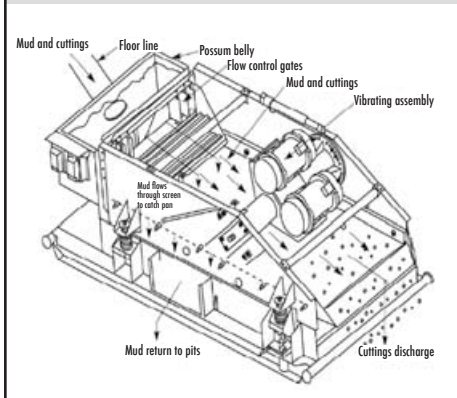

Figure 4.7.
Desander Hydrocyclone (MI
SWACO, 2008)



Drilling fluids and finer solids (i.e., silt and colloidal-sized particles) passing through the shaker screens are then pumped to additional equipment for further processing (such as centrifuging). The percentage of drilling fluids retained on the drill cuttings from the shakers varies depending on the particle size, the formulation of the drilling mud, the geologic characteristics of the formation being drilled, and other factors (USEPA, 2000a).

4.2.1.2 HYDROCYCLONES

Hydrocyclones (Figure 4.7) separate solid particles in a liquid suspension through centrifugal force gravity separation. As illustrated in Figure 4.8, a hydrocyclone typically has a cylindrical top section and a conical base. The liquid and solid mixture is fed tangentially into the cylindrical section, which creates a rotational fluid motion that induces high centrifugal force to facilitate gravity separation. The underflow (or “reject” material) consists of the denser solid particles that flow through the conical section and are discharged at the bottom opening. The overflow (or “accept” material) consists of the less dense drilling fluids and other liquids that are discharged at the top of the unit.

Hydrocyclones are designed to remove specific solids fractions. Examples are “desanders” and “desilters” used for sand- and silt-sized particle removal respectively. Manufacturers also provide shakers equipped with hydrocyclones mounted at the feed end of the shaker unit. Operators in Eastern Canada reported that hydrocyclones for desanding and desilting are rarely used when drilling SBM hole sections because of improved shaker efficiency in removing sand and silt sized particles.

Hydrocyclones typically are used with unweighted WBMs to remove sand and silt-size particles that cannot be removed by the shakers (CAPP, 2001). The units also remove barite along with the “reject” material; therefore they are normally not used with weighted drill fluid systems.

Figure 4.8.

Hydrocyclone Application (CAPP, 2001)

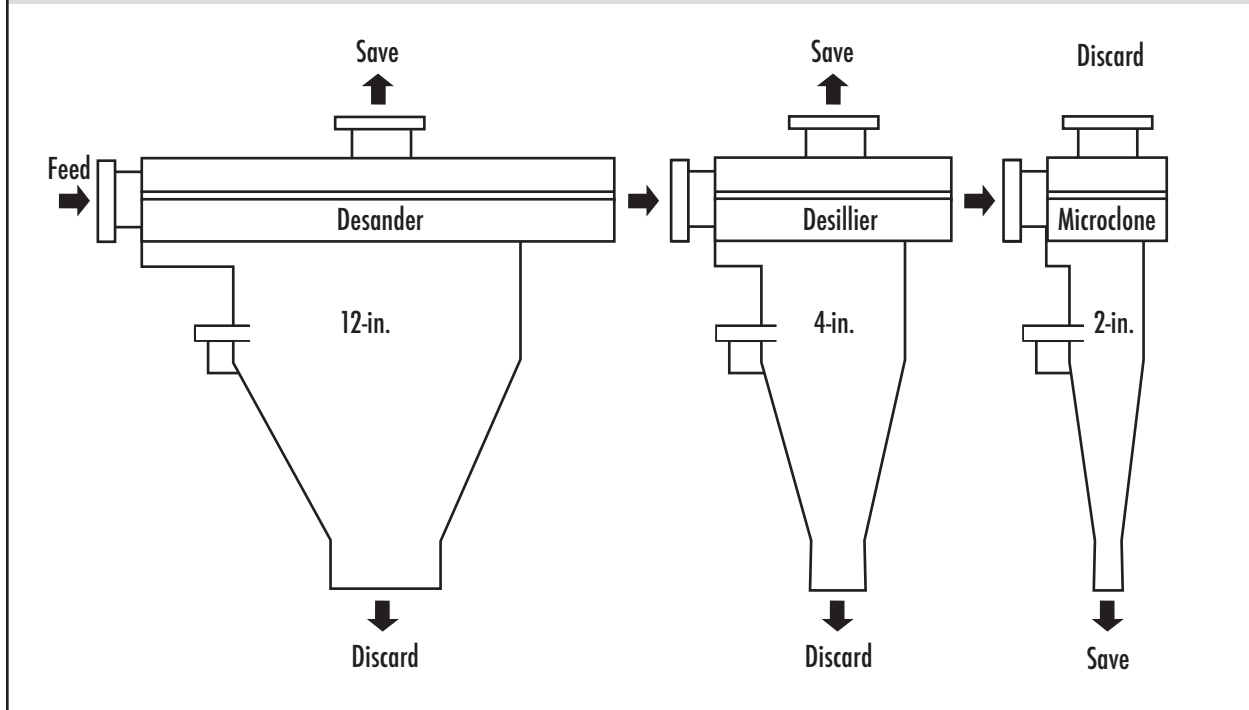

4.2.1.3 CENTRIFUGES

Centrifuges (Figure 4.9) are used to remove fine grained solids from the drilling fluids prior to recycling. They operate using similar gravity separation processes generated by centrifugal forces. However, centrifuges are capable of producing very high G-forces (i.e., in excess of 2,000 G's) to facilitate removal of very fine particles.

As shown in Figure 4.10, the feed is injected through an axial port located at the conical end of the unit. Solids are separated within the drying zone (termed the "beach") and conveyed to the discharge point, whereas liquids flow to the "pool" zone and are discharged at the opposite end. Primary solids-control systems commonly employ multiple centrifuge units for increased capacity as well as for a variety of solids separation functions.

Figure 4.9.

Decanter Centrifuge (MI-SWACO, 2008)



For weighted drilling muds, a centrifuge is commonly used to recover barite for recycling. For WBMs, the liquid phase containing detrimental drill solids is discharged and replaced with new volume. In dual-centrifuge configurations, the discarded liquid can be processed further to remove the low-gravity solids prior to recycling. (CAPP, 2001)

Figure 4.10.

Cross-Section of a Decanting Centrifuge (CAPP, 2001)

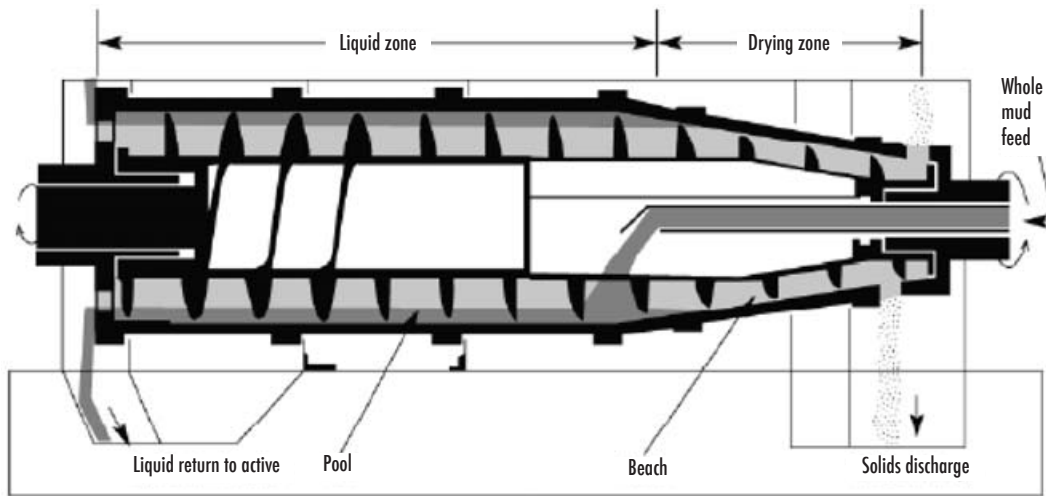

4.2.2 SECONDARY TREATMENT SYSTEMS

The two most common methods for secondary treatment to reduce drilling fluid retention on cuttings (ROC) are cuttings dryers and thermal desorption. Cuttings dryers are used routinely offshore in the Gulf of Mexico whenever SBM systems are used. Cuttings dryers cannot achieve the OSPAR limit of 1% ROC. Thermal desorption can achieve well below 1% ROC but poses logistical challenges and has mainly been used onshore.

Figure 4.11.

Example of Solids-Control System for SBM Drill Cuttings, Including Secondary Vertical Cuttings Dryer (OGP, 2003)

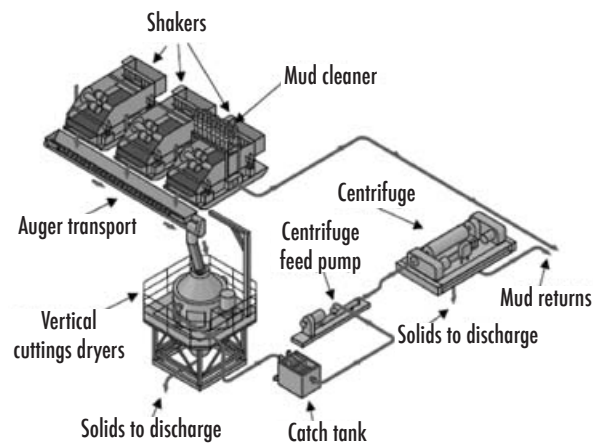

4.2.2.1 CUTTINGS DRYERS

A typical example of a cuttings dryer unit incorporated into a primary solids control system is shown in Figure 4.11. Drill cuttings from the shakers are sent to the cuttings dryer unit for secondary processing.

These devices were adapted from the coal industry where they are used to separate slurries of coal (CAPP, 2001). As shown in Figure 4.12, the design consists of a fine mesh screen mounted on a rotating basket that generates centrifugal forces for separation. The centrifuge may be horizontally or vertically oriented (Cannon and Martin, 2001). The Verti G™ cuttings dryer from MI-SWACO is a vertical mounted cuttings dryer. The Duster™ from Hutchison-Hayes uses a horizontal screen configuration.

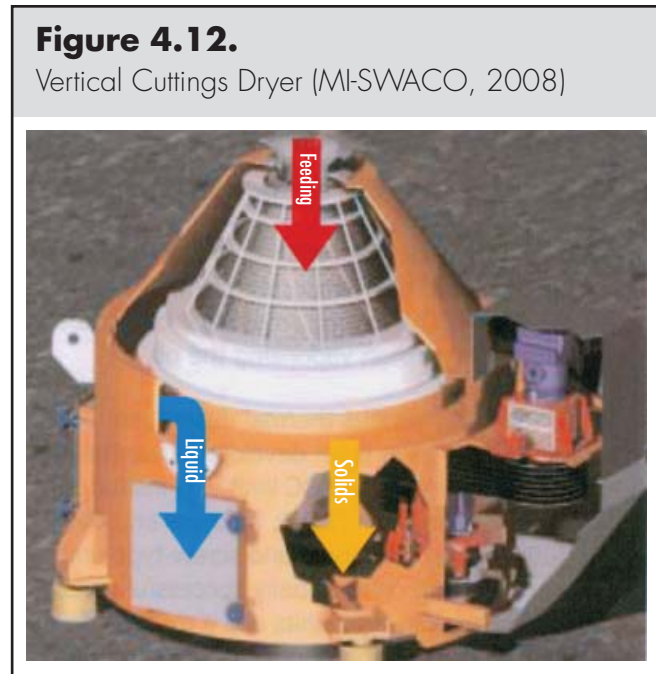

The fluids recovered from the cuttings dryer can be returned to the mud system for reuse. It is reported that the high concentration of fines in the recovered drilling fluids can require increased amounts of dilution of the recycled drilling fluid stream (CAPP, 2001).

Cuttings dryers are commonly used in the Gulf of Mexico. Melton et al. (2004) reported an example in which cuttings dryers reduced ROC from 11.8% to 2.1%. In a study of 23 wells using vertical cuttings dryers, Cannon and Martin (2001) reported that average ROC was reduced from 11.47% to 3.99%. ROC for individual wells ranged from about 2% to 6%.

Johnston et al. (2004) measured ROC for 72 wells drilled with SBMs in the Gulf of Mexico. The paper does not state what kind of cuttings dryers were used to comply with USEPA permit limits. Average ROC calculated over all SBM well intervals was 4.39% (standard deviation [SD] 0.832%). Use of BMPs in addition to mechanical treatment further reduced the levels to an average of 3.53% (SD 0.96%).

Getliff et al. (1997) reported that cuttings with low concentrations of adhering SBM have a lesser tendency to clump, and dispersion is greater as the cuttings settle through the water column. When cuttings containing <5% linear alpha olefin (measured by retort analysis) were discharged from a platform in the Amoco Arkwright Field in the North Sea, they dispersed in the water column and no cuttings pile accumulated on the bottom.

4.2.2.2 THERMAL DESORPTION METHODS

Figure 4.13.

Example of a Rotary Kiln-Type Thermal Desorption Plant for Onshore Treatment of Drill Cuttings (Jacques Whitford, 2002)



In the thermal desorption process, cuttings are heated to the distillation temperature of the base oil, and this temperature is maintained until essentially all of the oil is vaporized (Pierce et al., 2006). The cuttings must first be heated to vaporize water, and this actually requires much more energy than vaporizing the oil.

In the U.K., various thermal desorption techniques have been developed over the years since the 1% ROC limit was instituted (Stephenson et al., 2004; Kirkness and Garrick, 2008). Rotary kiln type and screw type units were the first commercially successful units. The rotary kiln-type units use a rotating drum that is heated either indirectly (by external burners) or directly (by internal burners). Screw type units use a hollow screw with a heated jacket instead of a rotating drum. Another method uses chemical treatment with concentrated acid to generate heat and disintegrate the cuttings particles. None of these approaches has proven adaptable for offshore use (Stephenson et al., 2004).

Figure 4.14.

TCC Heat Generation Mechanics. (Murray et al., 2008)

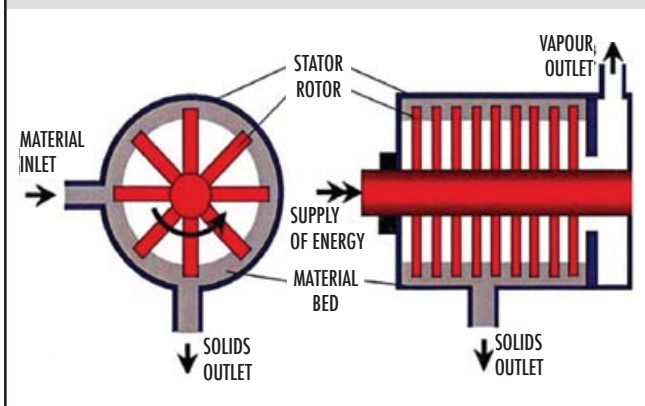

When first developed, thermal desorption required large, fixed onshore facilities because of the space and energy requirements (Stephenson et al., 2004). An example of a fixed onshore facility is shown on Figure 4.13. As a result, the U.K. industry turned to a “skip and ship” approach in which cuttings were boxed for transport to shore based facilities. However, the

loading and transfer of cuttings boxes involves significant cost, logistics and safety issues (e.g., potential for serious injury due to the large number of crane lifts) (Kirkness and Garrick, 2008). This has led to development of alternatives for bulk collection, storage and transfer (Morris and Seaton, 2006; Total Waste Management Alliance [TWMA], 2008) as well as cuttings reinjection (Alba et al., 2007).

A thermo-mechanical cuttings cleaner (TCC) system (Figure 4.14 and 4.15), also known as a hammermill system, has been successfully used both onshore and offshore. This technology, developed by Thermtech AS in Norway, is a friction based technique that involves a series of hammer arms mounted on a central drive shaft rotating at high speed in a process chamber. As the cuttings are passed through this chamber, friction from the hammers generates heat, which evaporates the water and then the oil from the cuttings. The evaporated gases are then passed through an oil condenser and steam condenser to recover the oil and water. The cuttings powder resulting from this process typically has a hydrocarbon content of <0.1%.

Murray et al. (2008) report that, from a physiochemical point of view, the TCC system has an advantage over traditional rotary kiln- and thermal screw-type technologies because of the low overall process temperature and very short retention time requirements for treatment. Since the process is based on direct mechanical heating, it eliminates the need for large heating surfaces and complex systems associated with conventional thermal desorption methods.

The TCC system has been successfully adapted for offshore use in the U.K. and approved by regulatory authorities for use in the North Sea (Stephenson et al., 2004). The TCC Rotomill™ operated by TWMA reportedly achieves a hydrocarbon content of <0.1%. According to Kirkness and Garrick (2008), this technology was fully commercialized in 2003 and since then has processed over 30,000 tonnes of cuttings offshore from the U.K. (According to the same authors, the U.K. generates over 80,000 tonnes offshore annually, so this represents a small portion of the total.) Halliburton (2007) states that their TCC system eliminates the need for (and all the associated costs and risks of) transferring cuttings from an offshore drilling rig to an onshore treatment facility. According to Murray et al. (2008), the TCC system operated by MI-SWACO is currently being employed to treat approximately 50,000 tonnes annually of oil based mud (OBM) in Kazakhstan.

Thermal desorption systems are generally of two types: low temperature systems and high temperature systems (OGP, 2008). Low temperature systems typically operate at 250° to 350°C, while high temperature systems may use temperatures up to 520°C. Low temperature systems may be sufficient to treat wastes with light oils. High temperature systems will be able to achieve lower final oil contents for wastes containing heavier oils. Modern thermal desorption units have variable temperature control. If the oil on cuttings can be removed at a lower temperature, significant savings can be realized by the operator because less energy will be required to reach the required <1% ROC. A further benefit of the lower temperature will be less inherent thermal degradation of the base oil (Fang et al., 2007). The TCC systems operate at temperatures between 240° and 260°C, so the recovered base oil is unaffected by heating and can be reused in the mud system. Wait et al. (2003) reported that the basic composition of virgin base oil, synthetic or mineral, is little altered after low temperature thermal desorption.

Figure 4.15.
TCC Thermal Desorption System for Offshore or Onshore Application (Thermtech, 2008)

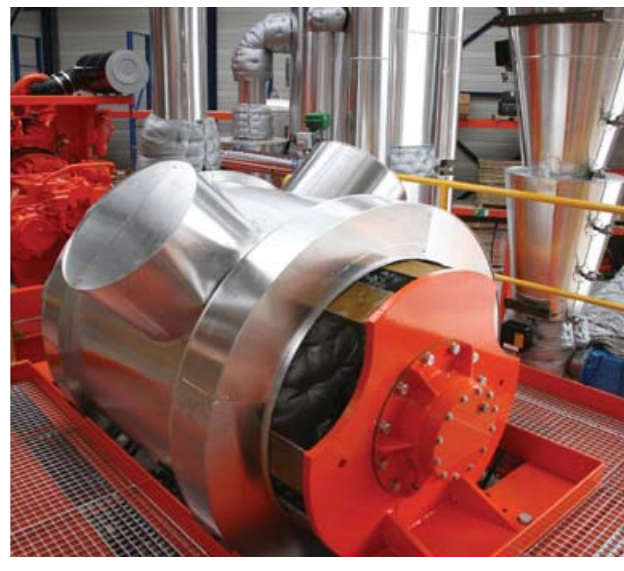

4.3 OTHER TECHNOLOGIES

Several other methods for reducing ROC have been studied and are in various stages of research and development. However, a review of industry websites (Halliburton/Baroid, TWMA, and MI-SWACO) suggests that the only technologies in commercial use offshore are cuttings dryers and thermal desorption using the TCC/ Hammermill method (see Section 4.2.2.2).

- Microwave Heating – This is a variation of the thermal desorption method. Shang et al. (2005) conducted a laboratory study demonstrating that oil-contaminated cuttings from North Sea platforms could be treated in a single-mode microwave cavity to reduce residual oil levels. However, with the samples investigated, the water content was not sufficient to reduce the oil levels to below 1% in a single process step at realistic treatment times. Robinson et al. (2008) subsequently reported on a pilot project in which the microwave treatment was improved and scaled up to a 500 kg/hr continuous process (Figure 4.16). The feed cuttings are conditioned in a solids mixer before being fed via a conveyor to a microwave cavity. The oil is removed and recovered with an extraction and condensation system, with the product oil being very similar in composition to the base oil in the drilling mud. Residual oil levels of <0.1% are obtainable, and cuttings throughputs of 500 kg/hr are possible using a 30-kW microwave source. The authors cite this as the first step in the development of a modular system with low deck impact, flexible processing rates and reduced environmental signature.

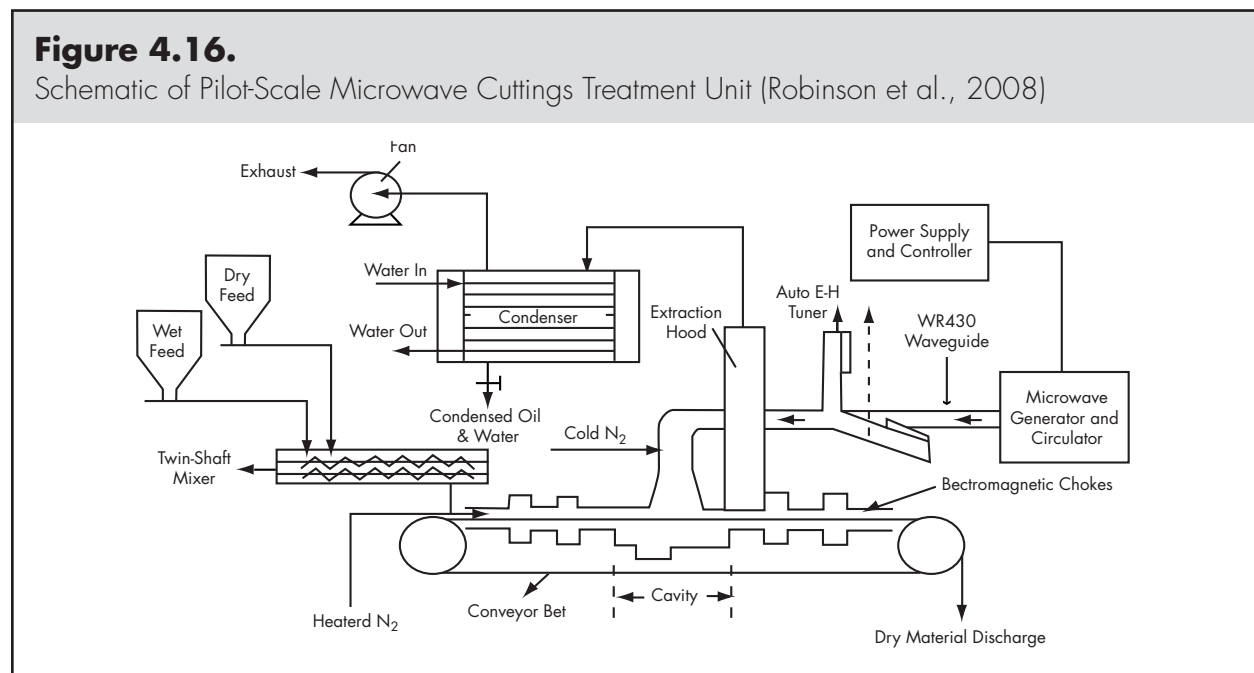

- † Supercritical CO₂ Extraction – Saintpere and Morillon Jeanmaire (2000) studied the possibility of supercritical CO₂ extraction to reduce residual oil on cuttings. Further research has been conducted by Street et al. (2007) and Esmailzadeh et al. (2008). According to Seaton and Hall (2005), a disadvantage of supercritical CO₂ extraction is the requirement for expensive high pressure equipment to turn CO₂ from a gas to a supercritical fluid, treat the cuttings and recover the extracted oil. This method has been used for other industrial applications, such as decaffeination of coffee beans, but not at the scale and capacity required for the offshore oil industry. At this point, the research is still in the laboratory phase. Further research and development would be needed to implement this method in the field.
- † Liquefied Gas Extraction – This technique is similar to the supercritical CO₂ extraction method. However, hydrocarbon gases (propane, butane) are used as solvents because they can be liquefied at much lower pressures than CO₂ and at ambient temperatures (Seaton and Hall, 2005). Laboratory tests showed that ROC less than 1% could be achieved for cuttings containing diesel oil, mineral oil and an olefin/ester SBM. This technology is currently being researched only for land based applications. Further research and development would be needed to implement this method in the offshore.
- † Bioremediation – This is an onshore treatment process (and sometimes disposal process) that is used in the U.K. for drilling wastes that cannot be treated offshore (Hall et al., 2007; OGP, 2008). OGP (2008) distinguishes three bioremediation methods: land farming, land treatment and composting. In land farming, waste is periodically re-applied to a receiving soil so that naturally occurring micro organisms present in the soil can biodegrade the hydrocarbon constituents. Land treatment methods include land spreading, biotreatment units and in-situ biotreatment; these methods differ from land farming in that they are a single treatment event rather than repeated applications of oily wastes. Composting is similar to land treatment, but biodegradation rates are enhanced by improving porosity, aeration, moisture content and operating temperature. Treatment times can be as short as months or as long as years, depending on the starting oil concentration and oil composition, as well as environmental conditions such as temperature, oxygen availability and moisture.
- † Chemical Washing/Surfactants – Muherei and Junin (2007) studied the possibility of using surfactants to clean oily cuttings. Mixtures of anionic and nonionic surfactant were found to be excellent candidates for robust cleaners. The technique was characterized as “promising” but would require much more research and development to be implemented for offshore application. This technology has been applied extensively for onshore treatment and processing of petroleum impacted soils.
- † Solidification/Stabilization – This is an onshore treatment process that uses binding agents, such as Portland cement, to physically encapsulate and chemically stabilize the chemical compounds. The technology has been used extensively for the treatment of oil impacted solids. As of 2004, approximately 30% of the remediation programs of the United States Environmental Protection Agency’s (USEPA) Superfund scheme utilizes this technology (Page et al., 2004)
- † Improved WBMs – Given the problems in treating non aqueous muds to meet increasingly stringent regulatory limits, there has been interest in developing improved WBM for more challenging geological formations. Dye et al. (2005) reported the development of a new high performance water based mud (HPWBM) designed to close the significant drilling performance gap between conventional WBM and emulsion-based mud systems. The system has undergone extensive field testing on very challenging onshore, deepwater and continental shelf wells that would otherwise have been drilled with oil-based mud or SBM. Eia and Hernandez (2006) similarly reported the use of a new WBM (Ultradril) as an alternative to SBM or oil based muds.

4.4 ALTERNATIVE CUTTINGS MANAGEMENT OPTIONS

In addition to offshore treatment and disposal, alternatives for disposal of drill cuttings include re-injection of cuttings into the geologic formation or transport of the cuttings to shore for onshore treatment and/or disposal.

4.4.1 CUTTINGS RE-INJECTION

Cuttings Re-Injection (CRI) is a waste disposal process wherein the drill cuttings are pumped into a subsurface geologic formation (Figure 4.17). The process typically involves grinding the cuttings and mixing with seawater to create a slurry capable of being injected. The injection operations are often conducted as a batch process. The three main drivers for selecting this technology for cuttings disposal are regulations, logistics and costs (Alba et al., 2007).

The development and use of this technology has grown significantly in recent years. For example, in the period of a decade or so, the maximum slurry volume injected into a single well has increased from approximately 30,000 bbl to several million barrels (Guo et al., 2007).

As shown on Figure 4.18, three methods employed for CRI include: 1) injection into the annulus of a well being drilled, or a producing well; 2) injection into a depleted well; or 3) disposal into a dedicated injection well.

According to Guo et al. (2007), CRI technology has grown beyond the development stage and is entering a high-growth phase. The paper further notes that the key challenges of CRI projects can include:

- + Local regulations and permitting;
- + Containment of injected waste;
- + Slurry rheology design;

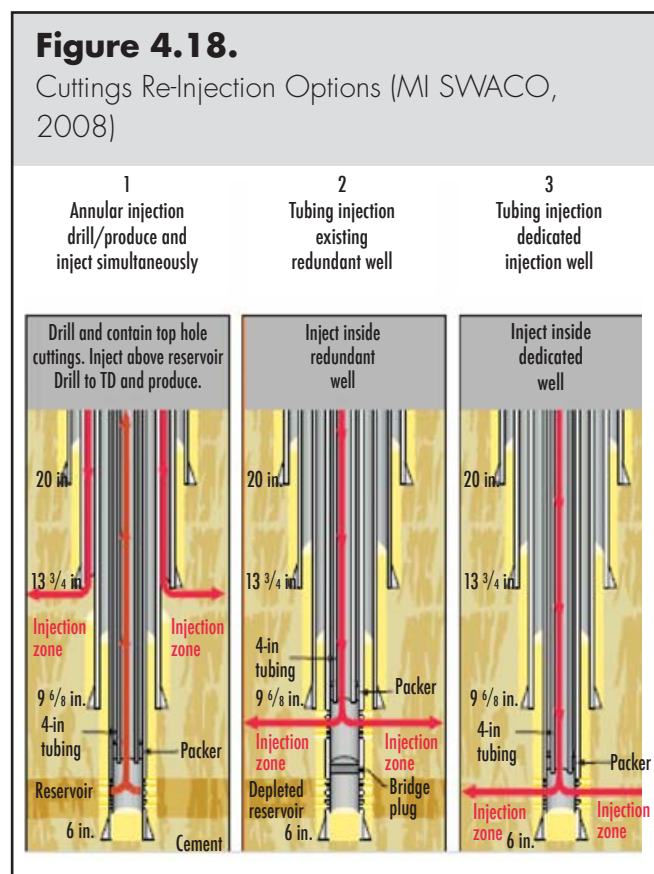
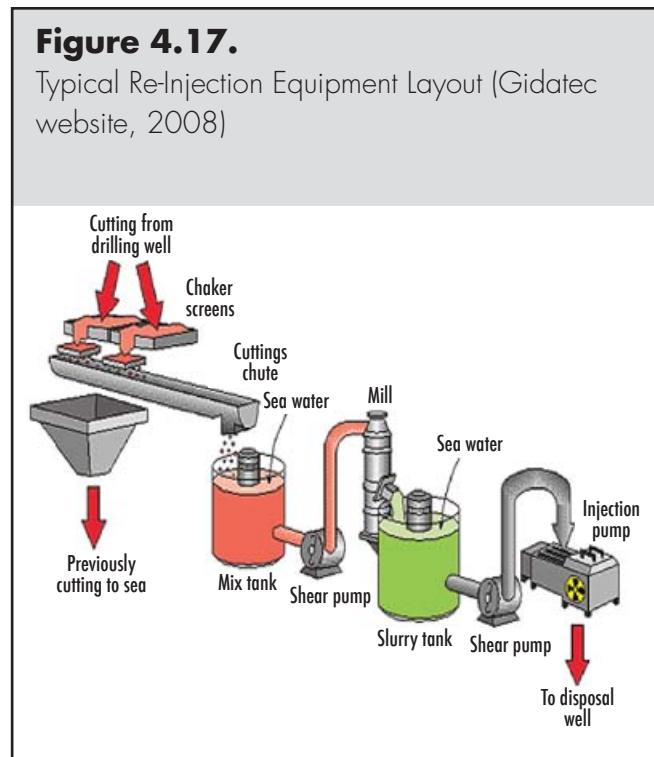

- Selection of injection and displacement procedures;
- Disposal well capacity;
- Surface equipment and grinding equipment problems;
- Monitoring and verification challenges.

Significant advancements have been made in the last decade with application of this waste disposal technology. The process requires intricate design and is subject to reservoir constraints. Front-end engineering of a CRI program typically includes detailed analysis of the subsurface geological characteristics, well design, slurry rheology, hydraulic fracturing simulations, operational procedure development, equipment specification, and risk identification and mitigation options (MI-SWACO, 2008). CRI operations also require a well planned monitoring and verification program to ensure quality control during and after injection operations.

As shown in Figure 4.19, equipment manufacturers offer specialized equipment for cuttings grinding, slurry preparation and injection.

4.4.2 SHIP-TO-SHORE CUTTINGS DISPOSAL

Safety and logistical aspects of transporting cuttings to shore for treatment (“skip and ship”; Figure 4.20) have been discussed by Morris and Seaton (2006) and Kirkness and Garrick (2008). Cost aspects have been addressed by USEPA (2000a). There are other environmental factors associated with skip and shipping drill mud and cuttings to shore that are not discussed in detail here, but they include issues such as fuel usage, air emissions, potential for spills in sensitive areas, and onshore treatment, storage and disposal impacts.

The main safety concern is the large number of crane lifts needed to transfer cuttings boxes between drilling rigs and onshore facilities. As noted by Morris and Seaton (2006), a typical offshore well can generate in excess of 1,000 tonnes of cuttings and require several hundred cuttings boxes. These boxes have to be lifted onto a boat, transported to the rig, lifted onto the rig, and then lifted to the filling station on the rig. Once filled with cuttings,

Figure 4.19.
Waste Injection System (MI-SWACO, 2008)



Figure 4.20.
Diagram of a “Skip and Ship” Operation (from Kirkness and Garrick, 2008).

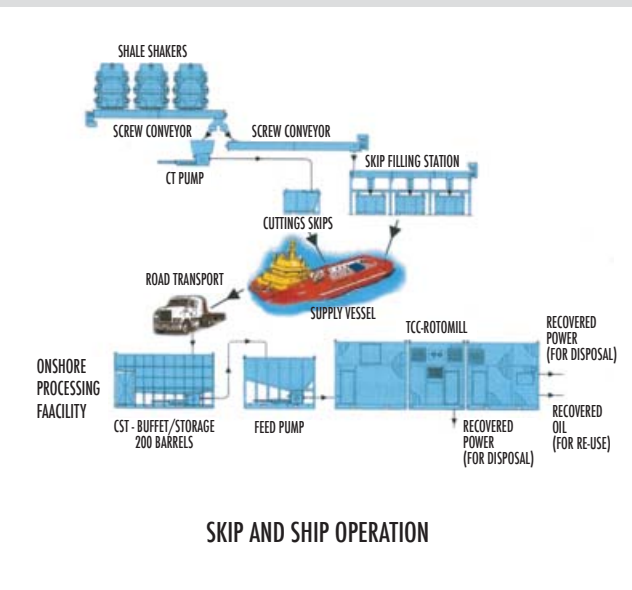

the box is lifted from the filling station, transferred down onto the boat, and finally lifted off the boat when it returns to the shore base. This means six or more crane lifts are required for each cuttings box filled, and at 200 boxes per well, this amounts to 1,200 individual crane lifts per well. This represents a significant safety risk to workers at the rig site, on boats, and at the shore base.

A slightly different set of figures is provided by Kirkness and Garrick (2008), as follows: “If, for example, the 80,000 tonnes of cuttings generated in the UKCS have to be taken ashore for treatment using these cuttings boxes, there will be at least 20,000 bins used. For each bin transported to the rig, filled and returned to a shore based processing facility, there are likely to be as many as 15 crane lifts, which over the year would total 300,000 lifts. This number of lifts, often in cramped spaces, will increase risk of injury to those involved in the process.”

Cuttings transport also poses logistical challenges because of the limited storage space available on offshore drilling rigs. Any delay in transferring cuttings boxes to or from the rig could result in a temporary shutdown of drilling operations (Kirkness and Garrick, 2008). This is especially true when drilling operations are taking place offshore in winter months, when weather conditions may make it difficult to transfer cuttings ashore as well as get empty cuttings boxes to the rig.

Alternatives for bulk collection, storage and transfer have been developed that avoid the need for cuttings boxes, thereby eliminating the safety issues associated with crane lifts (Morris and Seaton, 2006; Total Waste Management Alliance [TWMA], 2008). Tanks on the rig can be linked with the tanks on a ship by hoses, and either pneumatic techniques or pumps can be used to transfer the material. This eliminates the use of cuttings boxes and cranes, but the techniques could still be sensitive to weather related disruptions (e.g., affecting transport or loading).

The USEPA (2000d) estimated costs for a “zero discharge” option that would have required U.S. Gulf of Mexico operators to ship all SBM cuttings to shore for treatment and disposal. Included in the estimates were supply boat costs, trucking costs, disposal and handling costs, container rental costs, and offshore treatment. The cost of “zero discharge” was estimated to be US\$299,776 per deepwater development well and US\$688,473 per deepwater exploration well. These compare with net cost savings (based on recovery and recycling of SBM after treatment with cuttings dryers) of US\$2,785 per deepwater development well and US\$30,676 per deepwater exploration well. Essentially, the onshore disposal option would increase costs by over US\$300,000 per development well and US\$700,000 per exploration well. All figures are in 1999 U.S. dollars. These values are highly dependent on the detailed assumptions in the USEPA analysis.

5.0 TECHNOLOGY PERFORMANCE

5.1 DRILL CUTTINGS DISCHARGE QUALITY

The following sections provide a summary of recent information received from two major operators from the East Coast between 2002 and 2007.

5.1.1 SUMMARY OF RECENT STUDIES

There have been several studies completed in the US and other countries since 2000 to evaluate the average retention on cuttings (ROC) for synthetic base mud. A summary is presented in Table 5.1 below. In general, studies have shown varying results ranging from 4.8% to 12% ROC. Some studies focusing on cuttings dryer technologies have demonstrated reduced ROC as low as 2.1%. In one study, TWMA reported performance data from 23 wells comparing cuttings that were not processed in its dryer system (11.7%), and processed in its system (4.15%).

TABLE 5.1 SUMMARY OF PREVIOUS ROC STUDY FINDINGS

Study Reference	Study Outcomes	Notes
U.S. Environmental Protection Agency (USEPA, 2000a)	Primary Shale Shakers: 9.3%, Secondary shale shakers: 13.8% Other shale shakers: 9.0%	ROC summary from information of various shakers
Annis (1997)	ROC ranges of: 12.0% ± 4.8%	Evaluated 738 SBM cuttings samples from processing technology available in the mid 1990's
Kirkness and Garrick, 2008	ROC ranges of 15% to 20%	Summary of information of various shakers
Cannon and Martin (2001)	Vertical cuttings dryer: Average ROC was reduced from 11.47% to 3.99%.	Study based on 23 wells using the TWMA vertical cuttings dryer. ROC for individual wells ranged from about 2% to 6%.
Johnston et al. (2004)	ROC: 4.39%.	Measured ROC for 72 wells drilled with SBMs in the Gulf of Mexico; ROC calculated over all SBM intervals

5.1.2 DATA ASSESSMENT OF RECENT EAST COAST OPERATOR EQUIPMENT PERFORMANCE

Data were obtained from two operators and analysed in this report. To provide insight into the equipment performance of more recent East Coast drilling operations, the study compiled data from two major East Coast operators from 15 different wells between 2002 and 2007. In total, this study assessed over 1,365 SBM cuttings samples, representing 28,993 metric tonnes of SBM cuttings discharged to sea and over 9,600 hours of equipment operating time.

Operators provided data including dates and shift length, drilling depth, equipment utilized, discharge location, backup data for the calculation of %SOC over the SBM drilling section, and the location of the drill site. No WBM data were provided, nor was there supplemental information on other key variables such as geological characteristics, drilled depth, cuttings temperature and drill mud formulation. Also, no differentiations of equipment types were made because specific data were not available (e.g., shale shaker model, shaker screen size and centrifuge operational settings). Although these variables are not evaluated in detail, it is recognized that they play a key role in the ability of equipment to remove SBMs and the net residual %SOC.

ASSESSMENT OF INDIVIDUAL WELL DATA

Wells were first individually assessed based on the smallest increment of time reported (6 hours and 12 hours) and associated equipment configuration utilized to treat SOC and discharge cuttings to sea. As noted in Section 4, treatment of drill mud is often completed using one or more equipment types that are added or removed during the drilling program for a given hole. To account for this, similar equipment configurations were grouped together and the associated performance assessed. For example, data from an equipment configuration consisting of a Duster, Shaker(s) and Centrifuge were grouped with other configurations consisting of a Duster, Shaker(s) and one or more Centrifuge units. For each well, summary statistics were then generated for each equipment configuration set-up. The following statistics were then compiled for various equipment configurations for each well:

- %SOC Average: calculated by examining equipment utilized per individual time increment and associated cuttings discharge tonnage multiplied by the corresponding %SOC reported for that specific piece of equipment to establish a weighted average %SOC value for the equipment configuration during that time interval. These weighted average %SOC values were then averaged amongst the equipment configuration group to determine an overall average;
- Minimum %SOC value recorded for each group;
- Maximum %SOC value recorded for each group;
- Equipment configuration operating time per group; and
- Tonnage discharged per group

Further assessment of individual wells was completed to determine a per well mass weighted %SOC. This was achieved by dividing the cumulative oil discharged to sea by the cumulative mass of wet solids discharged to sea. The average %SOC, 90th percentile and 10th percentile were calculated.

ASSESSMENT OF DATA FROM ALL WELLS

SOC data were further aggregated to obtain a broader view of equipment performance over multiple wells. Using the initial assessment of data described above, equipment configurations from all 15 study wells were grouped together. The following summary statistics were then prepared for similar equipment configurations over 15 wells:

- %SOC Weighted Average: calculated by examining similar equipment configurations utilized over 15 wells. Average %SOC data (developed based on the individual well data) and associated discharge tonnage were weighted with those values within the group to develop a weighted %SOC average across all 15 wells.
- 10th Percentile: the value below which 10 percent of the %SOC values fall (not a weighted calculation);
- 90th Percentile: the value below which 90 percent of the %SOC values fall (not a weighted calculation);
- Maximum: the maximum %SOC value recorded for that equipment configuration;
- Minimum: the minimum %SOC value recorded for that equipment configuration;
- Summary of weight of cuttings discharged to sea per equipment configuration; and
- Total equipment configuration operating time.

SUMMARY OF PER WELL MASS WEIGHTED %SOC

Analysis of individual wells demonstrated that operators used combinations of equipment configurations for individual wells to achieve solids control and associated %SOC. Data results for individual wells are summarized in Table 5.2.

TABLE 5.2 PER WELL MASS WEIGHTED %SOC

Well Identification	%SOC	Well Identification	%SOC
1	11.07	9	8.09
2	9.30	10	8.15
3	9.62	11	7.66
4	7.84	12	7.48
5	8.21	13	6.08
6	7.69	14	8.51
7	8.64	15	7.73
8	9.78		

The average for all wells noted above by a mass weighted %SOC was 8.46 %.

Summary of Equipment Configuration Statistics, All Wells

Based on a review of data from 15 wells, there were 16 broad types of equipment configurations used at various times during drilling. The configurations changed throughout individual well drilling programs to accommodate site-specific conditions (such as geology, depth to surface, temperature and formulation). The results of the data compilation are summarized in Table 5.3 below.

TABLE 5.3 SUMMARY OF %SOC REMOVAL BY CONFIGURATION GROUPING

Equipment Configuration Reference	Configuration Description	Weighted Average %SOC on Cuttings	Treated Tonnage Discharged (mt)	Hours Operated
1	Duster Cuttings Dryer, Shaker(s), Centrifuge x 3	7.09	9,658	2,250
2	Shaker, Centrifuge x3	9.55	5,343	1,668
3	Centrifuge x 3	9.28	4,710	2,484
4	Duster Cuttings Dryer, Shaker(s), Centrifuge x 3, Duster Cuttings Dryer Centrifuge	9.07	6,825	2,166
5	Duster Cuttings Dryer, Shaker(s)	5.74	106	42
6	Shaker(s)	6.20	642	306
7	Duster Cuttings Dryer, Centrifuge x 3	6.58	39	12
8	Duster Cuttings Dryer, Centrifuge x 3, Duster Cuttings Dryer Centrifuge	9.35	156	54
9	Duster Cuttings Dryer, Shaker(s), Duster Cuttings Dryer Centrifuge	8.51	121	84
10	Duster Cuttings Dryer	5.75	9	6
11	Duster Cuttings Dryer, Duster Cuttings Dryer Centrifuge	14.4	11	6
12	Shaker(s), Centrifuge x 3, Duster Cuttings Dryer Centrifuge	9.49	327	168
13	Duster Cuttings Dryer Centrifuge	14.74	16	18
14	Centrifuge x 3, Duster Cuttings Dryer Centrifuge	10.86	45	12
15	Verti-G, Shaker(s), Centrifuge x 3	6.88	327	156
16	Verti-G, Shaker(s), Centrifuge x 3, Verti-G Centrifuge	8.15	11	12
Summary of Equipment Configurations		8.46	28,993	9,624

As noted in the above table, of the 16 equipment configurations the first four represented over 90% of the total weight of treated SBM cuttings discharged to sea and were used approximately 89% of the operating time. As further shown in Table 5-3, out of the total tonnage of material treated using cuttings dryers, approximately 98% of the material was treated using the Duster™ cuttings dryer, with only 2% utilizing the Verti-G™. An assessment of the treatment performance of the Duster™ versus Verti-G™ for Eastern Canadian application was not possible because of the limited amount of data provided for Verti-G™ performance.

A summary of the statistics is shown in Figure 5-1.

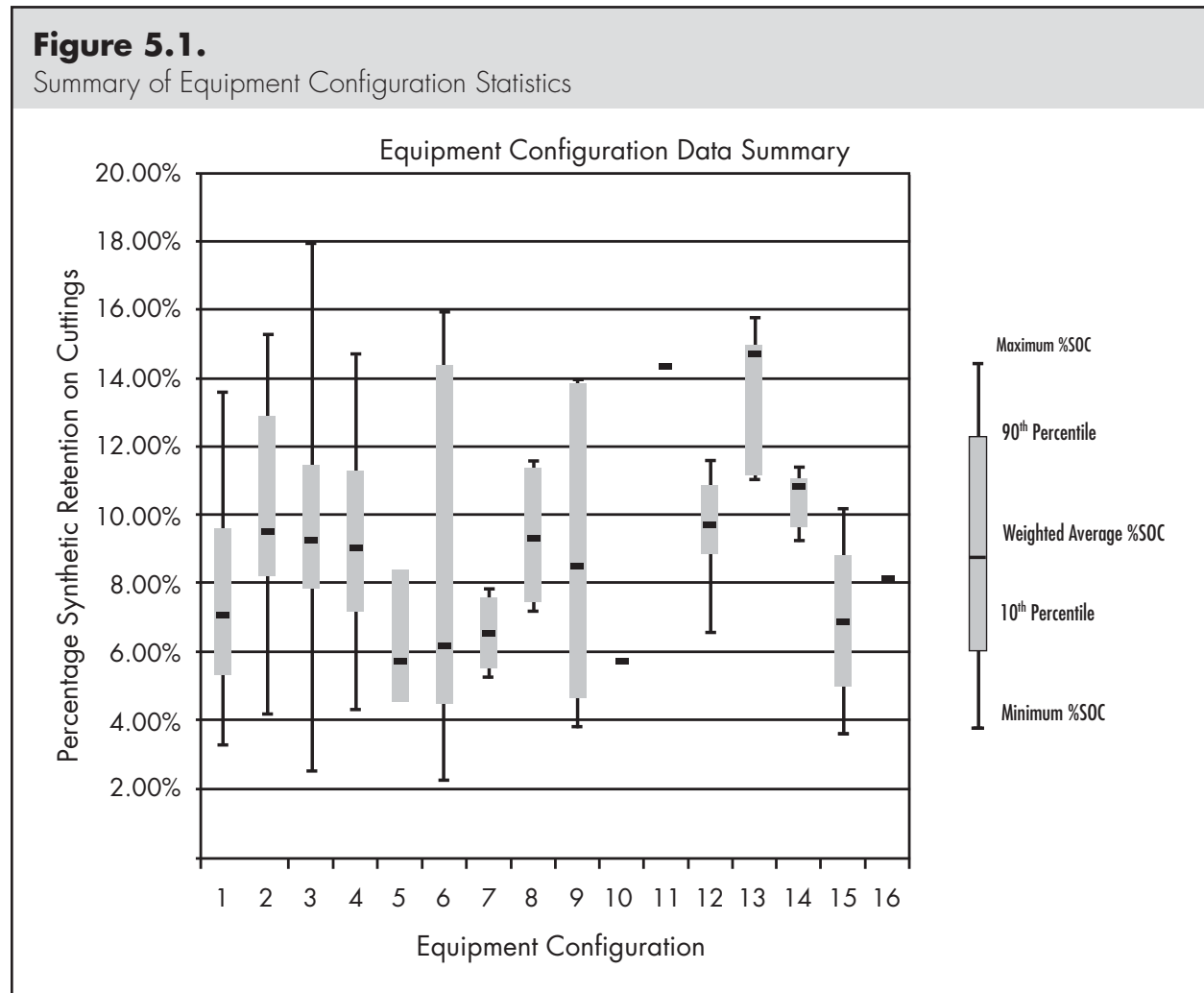

The results obtained from the configurations that processed over 90% of the cuttings (i.e., configurations 1–4), indicated that the weighted average %SOC ranged from 7.1 %SOC for Configuration 1, to 9.6 %SOC for Configuration 2. The lower 10th percentile was typically less than average by about 1.5% SOC, while the upper 90th percentile was between 2% and 3% SOC. All four configurations exhibited significant differences between the single highest (maximum) and single lowest (minimum) values for %SOC.

It is noted that the maximum and minimum %SOC recorded for equipment Configuration 5 is the same as the upper 90th percentile and lower 10th percentiles. Configurations 10, 11 and 16 each consist of a single instance where the respective equipment was utilized; therefore the data for these configurations is represented as a single weighted average %SOC.

DISCUSSION

The Offshore Waste Treatment Guidelines (National Energy Board et. al. 2002) serve as a guide for East Coast Offshore operators. In the regulatory guidelines referred to, 6.9% SOC (wet) is a recommended target based on using the best available technology. However, based on discussions with operators, the “best available technology” is necessarily a broad definition and applies to the best available technology associated with a specific rig and associated treatment equipment.

On a per well basis, study results indicate that using combinations of equipment configurations produced %SOC values of less than 6.9% for 1 of the 15 individual wells. Individual well data indicate a tighter range amongst the 90th and 10th percentiles with values of 9.7% and 7.6% SOC respectively with an average of 8.4% SOC.

The study results indicate that equipment configurations 5, 6, 7, 10 and 15 achieved a mass weighted average of 6.9% SOC. However, these equipment configurations represent less than 10% of the overall mass of cuttings discharged (based on this data set).

Of the four equipment configurations accounting for the discharge of the greatest weight of cuttings (1, 2, 3 and 4), none achieved a mass weighted average of 6.9% SOC. Of the 4 configurations that handled 90% of the mass, a target of 6.9% SOC was rarely achieved.

When all equipment configurations are grouped together, it appears that a mass weighted average %SOC (wet) of 8.5% was typically achieved. The 90th percentile calculated from all %SOC cuttings samples in the study (total of 1,365) was 11.6% SOC, and the 10th percentile was 6.3% SOC.

One operator reported that drilling operations conducted in the Nova Scotia offshore in 2002 were able to achieve the 6.9% SOC through utilization of a Verti-G™ cuttings dryer, combined with ship-to-shore of some drilling wastes. However, the provided data did not enable assessment of the Verti-G™ cuttings dryer stand-alone performance.

Another Canadian operator reported that enhanced cuttings treatment performance was achieved through the use of commercially available chemical additive(s) in conjunction with the solids-control separation equipment. However, further details of the characteristics of the additive(s) were not provided for review.

6.0 ENVIRONMENTAL EFFECTS MONITORING

The study team undertook a review of various studies and environmental effects monitoring (EEM) programs which have been published since the previous CAPP (2001) background document on offshore drilling mud and cuttings discharges. Continental Shelf Associates Inc.(CSA), based in Florida, USA, provided a significant contribution to this assessment.

6.1 REVIEW OF RECENT PUBLICATIONS

In order to synthesize the vast amount of data and update current knowledge on this subject, the team focused on the following 12 recent and key representative papers/studies:

- White Rose Environmental Effects Monitoring Program – Results 2005 - 2008 (Husky Energy, 2006, 2007, 2009 - Draft);
- US Minerals Management Service (MMS) Study of the Effects of Oil and Gas Exploration and Development at Selected Continental Slope Sites in the Gulf of Mexico (CSA, 2006);
- Risks Associated with Drilling Fluids at Petroleum Development Sites in the Offshore: Evaluation for the Potential of an Aliphatic Hydrocarbon Based Drilling Fluid to Produce Sedimentary Toxicity and for Barite to be Acutely Toxic to Plankton (Payne et.al., DFO, 2006);
- Environmental Effects of Exploratory Drilling Offshore Canada: Environmental Effects Monitoring Data and Literature Review – Final Report (Hurley and Ellis, 2004);
- Gulf of Mexico Comprehensive Synthetic Based Muds Monitoring Program (CSA, 2004);
- MAPEM Project Environmental Monitoring of Offshore Drilling for Petroleum Exploration Offshore Brazil (MAPEM, 2004);
- Impact Assessment and Benthic Recruitment Following Exploration Drilling in the South Caspian Sea (Tait et.al., SPE, 2004)
- Environmental Aspects of the Use and Disposal of Non-Aqueous Drilling Fluids Associated with Offshore Oil & Gas Operations (OGP, 2003);
- Assessment of Environmental Impacts from Drilling Muds and Cuttings Disposal Offshore Brunei (Sayle et.al., SPE, 2002); and
- Laboratory Exposures of Invertebrate and Vertebrate Species to Concentrations of IA-35 (Petro-Canada) Drill Mud Fluid, Production Water, and Hibernia Drill Mud Cuttings (Payne et.al., DFO, 2001).
- Health effect indicators in American plaice (*Hippoglossoides platessoides*) from the Terra Nova development site, Grand Banks, NL, Canada. (2005).
- HMDC (Hibernia Management Development Company Limited). 2009. Hibernia Production Phase Environmental Effects Monitoring Program – Year Six (2007).

These reports represent a total of over 100 well site studies. General conclusions resulting from the review of these studies are discussed below, however, the key findings of all of these reports are provided in Appendix B.

6.2 GENERAL CONCLUSIONS OF RECENT EEM STUDY REVIEWS

The base fluids in SBMs are synthesized organic compounds that do not contain the toxic components found in refined oils, such as aromatics and cyclic structures. The most common SBM types include esters, ethers, PAOs, detergent alkylate, LAOs, IOs, and dimethyl siloxane-based oligomeric siloxanes. SBMs do not pose any special hazards with respect to contaminants. Metal concentrations in SBMs are expected to be similar to those in WBM. With the exception of barium, these concentrations are typically similar to the range measured in uncontaminated marine sediments (Neff et al., 2000). SBM base fluids typically do not contain PAHs. Observations during monitoring programs indicate that concentrations of barium and some other metals (cadmium, chromium, copper, lead, mercury, and zinc) may be elevated in sediments around drillsites where SBM discharges have occurred. However, results from monitoring studies are somewhat inconsistent (e.g., no effects on metals, from SBM cuttings, other than barium were noted in the Brunei and White Rose studies).

The studies reviewed here represent a range of geographic locations, water depths, intensities of drilling activity, and types of drilling muds used. It would be difficult to compare these sites with respect to drilling mud and cuttings dispersion without a detailed analysis of current regimes and volumes discharged. However, Hurley and Ellis' (2004) observation appears to remain valid in this present update in that there is considerable consistency in the monitoring results despite differences associated with the volumes and types of drilling waste discharged, the scale and location of drilling, and variations in sampling programs. Indeed, OGP's (2003) compilation of field monitoring results at offshore drilling sites reveals a relatively consistent picture of the fate and effects drill cuttings associated with SBMs. The specific degree of impact is a function of local environmental conditions (water depth, currents, temperature), and the amount and type of waste discharged.

It is generally thought that the largest potential impact from discharge will occur in the sediment dwelling (benthic) community. The risk of water-column impact is low due to the short residence time of cuttings as they settle to the sea floor and the low water-solubility and aromatic content of the base fluid. In general, the various study results suggest that the primary cause of benthic effects in the nearfield was physical (i.e., burial) rather than chemical (toxicity). It is probable that within three to five years of cessation of SBM cuttings discharges, concentrations of synthetic in sediments will have fallen to sufficiently low levels and oxygen concentrations will have increased sufficiently in the previously affected area that complete recovery will be possible (Neff et al, 2000).

Impacts on the benthic biota are potentially due to several factors which include chemical toxicity of the base fluid, oxygen depletion due to SBM biodegradation in the sediments and physical impacts from burial or changes in grain size. At sites where SBFs were used, field studies show that recovery is underway within one year of cessation of discharges (OGP, 2003).

The studies generally indicate that environmental effects of SBM cuttings are far less severe than those reported for OBMs. This is evident both from the direct comparisons in the Brunei study (Sayle et al., 2001) and by comparison with impacts documented for OBM discharges in the North Sea (Davies et al., 1989; Olsgard and Gray, 1995; Bell et al., 1998). Large, thick cuttings piles such as those observed at various historical OBM sites in the North Sea were not reported in any of the SBM studies. SBM cuttings discharges have had far fewer effects on soft-bottom communities than OBM cuttings discharges, as effects on soft bottom communities from SBM cuttings discharges are rarely seen outside of 250-500 m (OGP, 2003).

In most cases the majority of cuttings appeared to be deposited within 100 to 250 m of the discharge site. Many of the studies indicate that benthic impacts are patchy, with some nearfield stations showing conditions similar to those at the far-field or reference sites (CSA, 2006). The severity of discharge-related impacts vary depending on the volume of SBM cuttings discharged and the time elapsed since drilling was completed.

The majority of the studies generally concluded that benthic community effects from offshore exploration drilling were most likely limited to within about 500 m of wellsites. However, many of these studies were not specifically designed to study a distance gradient or delineate the spatial extent of effects; rather, they used an impact-control design in which near-field and far-field (reference) locations were compared. Other aspects of the MMS (CSA, 2006) study (geophysical mapping for example) showed detectable accumulations extending up to 1 km from wellsites, and a few sediment samples detected drilling mud signatures at distances of 2 to 3 km. However, no corresponding benthic infaunal samples were taken at these locations. Likely causes of the benthic community impacts noted in the MMS (CSA, 2006) and SBM (CSA, 2004) related studies include organic enrichment and redox changes associated with SBM cuttings deposits, as well as outright burial and gross changes in sediment texture due to both WBM and SBM cuttings deposits in the near-field. According to this interpretation, small but detectable mud and cuttings accumulations at distances greater than about 500 m would be unlikely to produce significant benthic community effects.

Both the White Rose and Brunei studies (exploration and production drilling) provided some evidence for more extensive benthic community effects. This is due in part because production drilling generates substantially larger volumes of mud and cuttings (which require more holes to produce) than does single hole exploration drilling. Exploration drilling represented most of the other studies. For example, USEPA (1991) reports that the average volume of mud and cuttings from an exploration well in the Gulf of Mexico is 8,379 bbls. In comparison, up to the time of their 2006 survey, the following drilling discharges had been made at the White Rose production drilling centres (Husky, 2007): WBM Cuttings (7,198,338 MT); WBM (10,433 m³); SBM Cuttings (18,247 MT); and, SBM (1,947 m³).

In the White Rose program, the zone of effects on benthic invertebrates extended to 1 to 5 km from the production drill centers. However, the causal mechanism for effects beyond the near-field is not clear. Neither barium nor SBM hydrocarbons are likely to be responsible – barium is not toxic, and concentrations at these distances were within the range of background levels; hydrocarbon concentrations were approximately three orders of magnitude below the laboratory effects threshold. Distance gradients were steep in all years, with hydrocarbon concentrations decreasing by 100- to 1,000-fold over 10 km. The report suggests that the community effects observed (abundance and composition) could be due to indirect effects, chronic toxicity involving longer term exposure, or some correlate of hydrocarbon concentrations. However, there were no detectable project effects on many other benthic invertebrate community summary measures including, richness, diversity, and evenness. In contrast to the documented sediment contamination and benthic invertebrate effects, no effects (taint, body burden, health indices) on commercial fish were identified (Husky, 2007).

There was clear evidence in the White Rose program that concentrations of two drilling mud indicators (barium and >C10-C21 hydrocarbons) were elevated by drilling activity near drill centers. Barium contamination extended to 2 km from source, and >C10-C21 hydrocarbon contamination extended to 10 km from source. Overall, concentrations of >C10-C21 hydrocarbons were a better indicator of drilling activity for White Rose than barium. From 2004 to 2008, total abundance was approx. 20-40% lower at stations within 2 km from

active drill centres. However, there were no detectable project effects on many benthic invertebrate community summary measures including richness, diversity, and evenness (and standing crop when all years data are considered). The variables affected and the strength of effects varied among sampling years and also among drill centers, and there have been few consistent response patterns. Survival in toxicity tests was not significantly correlated with >C10-C21 hydrocarbon concentrations in any post-drilling year, and correlations with various distance measures were weak and usually not significant. The estimated spatial extent of effects was generally less extensive than the zone of chemical influence, and within the range seen in other comparable studies in the North Sea. A more detailed summary of the White Rose EEM program is provided in Appendix B.

At one of the Brunei study sites (also a production area), SBM cuttings piles were mainly localized within 150 to 200 m of the wellsite, with extensive anoxic conditions and bacterial mats, but effects on benthic macrofaunal diversity were reported to extend to 1.6 to 2 km from the wellsite. This zone of influence was attributed to the relatively large volume of cuttings at this multi-well production site, as well as the potential of formation hydrocarbons on cuttings which were more widely distributed during the WBM drilling phases at this location.

During the period 1997 to 2006, the Terra Nova project monitored various offshore sediment, water and commercial fish environmental parameters. There were no detectable effects on water quality over the course of the monitoring program. Levels of hydrocarbons in the sediments were found to be less than 4mg/kg beyond drill centres at 2km (2000 and 2001), 3km (2002 and 2006) and 3.5km (2006). Median levels of HC's ranged from 4.30 mg/kg in 2006 to 1.57mg/kg in 2000, with maximum values located within 150m of drill centres in all years except 2000 which found a maximum value of 13.3mg/kg at a distance of 750m. Similarly, maximum barium concentrations were within 250m of drill centres, and typically within 150m. Some elevated sulphur and sulphides were found in the immediate vicinity of the drill centres (along with lower Redox levels). A mix of potential enrichment (i.e., polychaetes) and inhibitory responses (i.e., amphipods) of certain benthic community structure indicators was observed near drill centres in 2001 to 2006. HC's were noted at various levels in scallops from the study area, and in plaice livers (however, chromatography resembled fatty acids rather than drill mud HC's). Effects measured for all parameters of the monitoring program were within predicted levels.

Hibernia is a crude oil production and drilling platform located approximately 315 km east of St. John's. Up until 2007, two drill rigs operated simultaneously at Hibernia. Prior to the start-up of the cuttings reinjection system in 2001-02, both drill rigs discharged treated cuttings at essentially the same location.

The 2007 EEM data indicates that hydrocarbons in sediments have returned to or below the 1998 levels. The 2007 total barium and weak acid leachable barium levels are also comparable to the 1998 levels.

The overall change in the sediment quality observed at Hibernia is directly attributed to the cessation of discharge of drill cuttings containing residual drilling fluid once reinjection of cuttings commenced in 2001. When cuttings reinjection was first commissioned in 2001 only the coarse cuttings from the shakers were reinjected. Drilling waste solids from the discharge line on the centrifuges were not reinjected initially thus the finer solids were still discharged to sea.

In September 2002, the centrifuge discharge line was permanently connected to the cuttings reinjection system. This enabled all drill cuttings, fines and coarse cuttings, to be reinjected continuously except during periods of cuttings reinjection system downtime.

The observed reduction in concentrations of hydrocarbons in sediments in 2002, when compared to 2000 data, is of particular interest. The highest recorded concentration in 2000 was 4170 mg/kg (sample closest to the platform) compared to 798 mg/kg in 2002; a substantial reduction. This reduction occurred over an approximately two year period when fines from the centrifuges were still being discharged and when the Offshore Waste Treatment Guidelines limit for synthetic oil on cuttings was set at 15%. Also no downtime of the cuttings reinjection system occurred during this period which resulted in the need to discharge cuttings.

Similar substantial reductions in concentrations of hydrocarbons in sediments were observed in 2004 and 2007 EEM programs when the highest concentrations were recorded as 134 and 81 mg/kg respectively.

Primary literature and industry reports on the effects of drill mud and cuttings have been reviewed in MMS (2000), CAPP (2001a), NEB et al. (2002), Buchanan et al. (2003), Hurley and Ellis (2004) and Neff (2005). Results from the EEM programs at Hibernia, White Rose and Terra Nova have, with some specific exceptions (see details in Appendix B), confirmed generally their respective assessment predictions of no significant effect on the marine environment for those production projects. Mathieu et al. (2005) and Deblois et al. (2005) also concluded that the Terra Nova project demonstrated no significant effects on fish health and fish habitat after a three-year period where six wells were drilled using a combination of water-based and synthetic-based muds.

Concentrations of monitored components of SBM cuttings in sediments tended to decrease or return to background values with time after the last cuttings discharge. Changes to benthic communities were not severe, even at the sites that were the most heavily contaminated with drill cuttings, and probably were caused primarily by organic enrichment of sediments by deposition of biodegradable SBM cuttings (CSA, 2004). Where impacts were observed, progress toward physical, chemical, and biological recovery appeared to occur within one to several years. Possible mechanisms included microbial biodegradation (breaking down of materials by microorganisms) and burial by natural sediment deposition or bioturbation (reworking of sediments by marine organisms).

SBMs are not expected to bioaccumulate significantly because of their extremely low water solubility and consequent low bioavailability. Their propensity to biodegrade further reduces the likelihood that exposures will be long enough that a significant bioaccumulative hazard will result. Cuttings discharged with SBFs have resulted in smaller zones of impact on the seafloor, and the biological community recovers more rapidly (OGP, 2003).

7.0 CONCLUSIONS

This study represents a summary of information up to 2008, and includes recent SOC data between 2002 and 2007 from two major East Coast operators. Key conclusions from this study are as follows:

SBM DRILL CUTTINGS CHARACTERISTICS

- SBMs have been developed in recent years to provide the oil and gas industry with an environmentally improved alternative to OBMs. SBMs are distinguished by the use of a synthetic base fluid (SBF) instead of water or oil. Because SBMs have low toxicity and high biodegradability, cuttings generated with these muds have been permitted for offshore discharge in many jurisdictions, often subject to effluent limits.
- SBMs are prepared synthetically and as such are well characterized and free of substantial impurities. The base fluids in SBMs are synthesized organic compounds that do not contain the toxic components found in refined oils, such as aromatics and cyclic structures. The most common SBM types include esters, ethers, iso-alkanes, poly-alpha-olefins, detergent alkylate, linear alpha-olefins, isomerized olefins and dimethyl siloxane-based oligomeric siloxanes (Hart et al., 2007). Metal concentrations in SBMs are expected to be similar to those in WBMs. With the exception of barium, these concentrations are typically similar to the range measured in uncontaminated marine sediments (Neff et al., 2000). SBM base fluids typically do not contain polynuclear aromatic hydrocarbons.

REGULATORY STANDARDS AND GUIDELINES

- The disposal of drill mud and cuttings in Eastern Canada is currently controlled under the Offshore Waste Treatment Guidelines, 2002. Under these Guidelines, drill cuttings associated with SBM are to be re-injected, and where this option may not be technically feasible, the cuttings may be discharged to sea provided that they are treated first with the best available technology. At the time when these guidelines were published, the best available treatment technology in some regions of the world was believed to be 6.9 g/100 g or less of oil on wet solids and 6.9% was set as the allowable discharge limit for synthetic oil on cuttings (SOC). This discharge limit may be modified in individual circumstances where more challenging formations and drilling conditions are experienced or areas of increased environmental risk are identified. In Nova Scotia, the 6.9% guideline has been reached through a combination of treatment system technologies and other management controls, such as ship to shore.
- The SOC concentration of 6.9% noted in the Offshore Waste Treatment Guidelines (2002) was based on the USEPA results obtained from the Gulf of Mexico. This retention on cuttings limit was developed by the USEPA based on a statistical analysis of data from 65 wells and representing four cuttings dryer technologies (USEPA, 2000c). In this study, the USEPA noted that the well average retention on cuttings measurements from Canada were all higher than those found in the Gulf of Mexico, arguing that the Canadian data do not belong to the same probability distribution as that associated with the data from the Gulf of Mexico. USEPA concluded that because these technologies appear physically and statistically different, a single distribution for retention on cuttings from any combination of cuttings dryer technologies does not exist for multiple regions (USEPA 2000b). The difference in retention on cuttings appears to be associated with variation/differences in geological formations (coarser materials generally associated with the Gulf of Mexico), and differences in the well bottom hole assemblies, all resulting in higher %SOC in the Canadian offshore wells.

- The majority of the technology-based limitations pertaining to the disposal of SBM on cuttings worldwide have to do with percent retention of mud on cuttings. The Gulf of Mexico has additional limitations, including toxicity testing and biodegradation. Australia has added a limitation stipulating the size of the drill hole for which SBM may be discharged. Other countries, including Norway, have prescribed environmental monitoring programs as a means of measuring treatment performance, and still others have no restrictions on the disposal of SBM.

DRILL CUTTINGS TREATMENT TECHNOLOGY

- The primary function of a typical solids-control treatment system is to efficiently remove the solids from the treatment stream in order to maximize the recovery and recycling of the costly drilling fluids. Maximizing the recycling of drilling fluid also reduces the total volume of spent SBM drill fluids that must be disposed of upon completion of drilling operations.
- Carrying forward the definitions defined by OGP (2003), primary treatment systems are aimed at solids removal and drill fluids recovery, as well as achieving environmental compliance requirements. Secondary treatment systems are additional equipment that may be added to increase drilling fluid recovery and/or assist in achieving stringent regulatory compliance requirements for offshore cuttings discharge.
- Primary solids control equipment (e.g., shakers and centrifuges) has remained the main component for removal of SBMs on cuttings. Although refinements have been made to primary treatment equipment, these technologies remain relatively similar to 2002 designs. There is no one specific treatment process that can be defined for all primary solids-control applications. The number and type of system components are selected according to the site specific drilling requirements (e.g., volumes to be treated, variability in formation, production rate), and brought online or offline during the course of drilling operations as required.
- The two most common methods for secondary treatment to reduce drilling fluid retention on cuttings (ROC) are cuttings dryers and thermal desorption. Although other innovative technologies, such as microwave treatment, have been studied, they are not available on a full-scale commercial basis.
- The design of cuttings dryers consists of a fine mesh screen mounted on a rotating basket that generates centrifugal forces for separation. The centrifuge may be horizontally or vertically oriented (Cannon and Martin, 2001). The Verti-G™ cuttings dryer from MI-SWACO is an example of a vertical mounted cuttings dryer. The Duster™ from Hutchison-Hayes utilizes a horizontal screen configuration.
- In the thermal desorption process, cuttings are heated to the distillation temperature of the base oil, and this temperature is maintained until essentially all of the oil is vaporized. When first developed, thermal desorption required large, fixed onshore facilities because of space and energy requirements. A thermo-mechanical cuttings cleaner (TCC) system, also known as a hammermill system, has been successfully used both onshore and offshore. The cuttings powder resulting from this process typically has a hydrocarbon content of <0.1%.
- In addition to offshore treatment and disposal, alternatives for disposal of drill cuttings include cuttings re-injection (CRI), or transport of the cuttings to shore for onshore treatment and/or disposal (i.e., ship-to-shore). Significant advancements have been made in the last decade with CRI. The process requires intricate design and is subject to reservoir constraints. For ship-to-shore, a key safety concern is the large number of crane lifts needed to transfer cuttings boxes between drilling rigs and onshore facilities. Cuttings handling and transport also pose logistical challenges because of the limited storage space available on offshore drilling rigs.

TECHNOLOGY PERFORMANCE

Drill cuttings treatment performance was based on information received from two major operators on Canada's East Coast from 2002 to 2007.

- The study results indicate that on a whole well basis, the 6.9% SOC is seldom achieved (1 of 15 wells in the Eastern Canada examples that were studied achieved 6.9% SOC between 2002 and 2007). It was found that the per-well mass average %SOC was 8.46%.
- Four equipment configurations accounted for discharging the greatest weight of cuttings. Of these top four, the average %SOC ranged from 7.09 to 9.55.
- During specific periods of treatment, a 6.9% SOC was achieved. However, the associated treated mass of cuttings discharged (less than 6.9% SOC) represented less than 10% of the total treated mass of 15 assessed wells.
- One operator reported that drilling operations conducted in the Nova Scotia offshore in 2002 were able to achieve the 6.9% SOC through utilization of a Verti-G™ cuttings dryer, combined with ship-to-shore transport of some drilling wastes. However, the provided data did not enable assessment of the Verti-G™ cuttings dryer stand-alone performance.

ENVIRONMENTAL EFFECTS MONITORING

- The environmental effects on benthic communities from SBM drill cuttings discharge appear to be generally limited to within 500 metres of the discharge point. This area may be extended in production drilling areas where volume and duration of discharges are greater. Available EEM studies indicate that SBMs do not appear to have specific ecotoxicological effects. Synthetic base fluids typically do not contain PAHs, and with the exception of barium, metal concentrations are usually similar to the range measured in uncontaminated marine sediments.
- SBMs are not expected to bioaccumulate significantly because of their extremely low water solubility and consequent low bioavailability. Their propensity to biodegrade further reduces the likelihood that exposures will be long enough for a significant bioaccumulative hazard to result. Cuttings discharged with SBMs have resulted in smaller zones of impact on the sea floor, and the biological community recovers more rapidly (OGP, 2003).
- At sites where SBMs were used, field studies (Appendix B) typically show that strong indications of recovery occur within one to five years from cessation of discharges.

In summary, this study has concluded that technologies available for the treatment of drill cuttings have remained essentially unchanged since 2002, with the exception of advances in cuttings dryers and thermal desorption technologies. Performance of offshore treatment systems for SBM drill cuttings from 2002 to 2007 rarely achieved the 6.9% SOC concentration on a "per well" basis, based on the information reviewed. These results are consistent with the USEPA findings in 2000 that also reviewed data from Canada. With some exceptions, the environmental effects on benthic communities from SBM drill cuttings discharge appear to be generally limited to within 500 metres of the discharge point for exploration drilling. At sites where SBMs were used, field studies typically show that strong indications of recovery occur within one to five years from cessation of discharges.

8.0 CLOSURE

This report has been prepared solely for the benefit of the Environmental Studies Research Fund. The report may not be used by any other person or entity without the express written consent of Environmental Studies Research Fund and Jacques Whitford Stantec Limited.

Any use made of this report by a third party, and any reliance on decisions made on the basis of this report, are the responsibility of such third parties. Jacques Whitford Limited accepts no responsibility for damages, if any, suffered by any third party as a result of decisions made, or actions taken, based on this report.

The information and conclusions contained in this report are based on work undertaken by trained professional and technical staff in accordance with generally accepted engineering and scientific practices current at the time the work was performed. Conclusions and recommendations presented in this report should not be construed as legal advice.

p:\enveng\103xxxx\1038084 esrf drill cuttings\reporting\final report\drill cuttings final report vr2.2.doc

9.0 BIBLIOGRAPHY REFERENCES

Alba, A., F. Fragachan, A. Ovalle and T. Shokanov. 2007. Environmentally Safe Waste Disposal: The Integration of Cuttings Collection, Transport, and Reinjection. 2007 International Oil Conference and Exhibition, 27–30 June 2007, Veracruz, Mexico. SPE 108912.

Annis, M.R. 1997. Retention of synthetic-based drilling material on cuttings discharged to the Gulf of Mexico. Report for the American Petroleum Institute (API) ad hoc Retention on Cuttings Work Group under the API Production Effluent Guidelines Task Force. API, Washington, DC. 29 August 1997.

Association of Oil & Gas producers (OGP) Report No. 342, 2003. Environmental aspects of the use and disposal of non aqueous drilling fluids associated with offshore oil & gas operations.

Buchanan, R.A., J.A. Cook and A. Mathieu. 2003. Environmental effects monitoring for exploration drilling. LGL Report No. SA735 by LGL Ltd., CEF Consultants Ltd., and Oceans Ltd. for Environmental Studies Research Funds, Calgary, Alberta.

Canadian Association of Petroleum Producers, February 2001. Technical Report, Offshore Drilling Waste Management Review.

Cannon, R.W. and Dale Martin. 2001. Reduction of Synthetic-Based Fluid Discharges Offshore by the Use of Vertical Basket Centrifuges. SPE/EPA/DOE Exploration and Production Environmental Conference, 26–28 February 2001, San Antonio, Texas, USA. SPE 66535.

CSA International Inc. 2004. Gulf of Mexico Comprehensive Synthetic Based Muds Monitoring Program.
CSA International Inc. 2006. U.S. Minerals Management Service (MMS) Study of the Effects of Oil and Gas Exploration and Development at Selected Continental Slope Sites in the Gulf of Mexico.

CSA International Inc. 2008. Offshore Drilling Mud and Cuttings Study.

Dahle S., & Camus L. 2007. Oil and Gas Development in the Barents Sea – A Knowledge Base and Integrated Approach for Safeguarding the Environment.

Davies, J.M., D.R. Bedborough, R.A.A. Blackman, J.M. Addy, J.F. Appelbee, W.C. Grogan, J.G. Parker, and A. Whitehead. 1989. Environmental effect of oil-based mud drilling in the North Sea, pp. 59–90. In: F.R. Engelhardt, J.P. Ray, and A.H. Gillam (eds.), *Drilling Wastes*. Elsevier Applied Science Publishers, London.

Deblois, E.M., C. Leeder, K.C. Penny, M. Murdoch, M.D. Paine, F. Power, and U.P. Williams. 2005. Terra Nova environmental effects monitoring program: from environmental impact statement onward. Pp. 475–491. In: *Offshore Oil and Gas Environmental Effects Monitoring: Approaches and Technologies*. Edited by S.L. Armsworthy, P.J. Cranford and K. Lee. Batelle Press, Columbus, Ohio.

Dorn et al. Development, Verifications, and Improvement of a Sediment-Toxicity Test for Regulatory Compliance. First presented at the 2005 SPE/EPA/DOE Exploration and Production Environmental Conference, Galveston, Texas, 7–9 March. Peer review in January 2007.

Drilling Fluids Management – Australian Gov't (2006). <http://www.doir.wa.gov.au/documents/ED_Pet_GL_DrillingFluidMgmt_Dec06.pdf>

Dye, W., K. Daugereau, N. Hansen, M. Otto, L. Shoults, R. Leaper, D. Clapper and T. Xiang. 2005. New Water-Based Mud Balances High-Performance Drilling and Environmental Compliance. SPE/IADC Drilling Conference, 23–25 February 2005, Amsterdam, Netherlands. IADC/SPE, 92637.

EEM Drilling Offshore Canada, 2004. Environmental Effects of Exploratory Drilling Offshore Canada: Environmental Effects Monitoring Data and Literature Review – Final Report. <http://pr-ac.ca/files/drilling_offshore_DOC_Oct_26_2004.pdf>

Eia, J.T. and E. Hernandez. 2006. Environmental Advances in Drilling Fluids and Waste Operations Applying Novel Technology for Fluid Recovery and Recycling. 2006 Russian Oil and Gas Technical Conference and Exhibition, 3–6 October 2006, Moscow, Russia. SPE 102737.

Energy Information Administration, Office of Oil and Gas. 2005. Overview of U.S. Legislation and Regulations Affecting Offshore Natural Gas and Oil Activity.

Environmental Division, Petroleum Branch, Department of Industry and Resource. 2006. Drilling Fluids Management.

- Esmailzadeh, F., I. Goodarznia, and R. Daneshi. 2008. Solubility Calculation of Oil Contaminated Drill Cuttings in Supercritical Carbon Dioxide Using Statistical Associating Fluid Theory (PC-SAFT). *Chemical Engineering & Technology* 31 (1): 66–70.
- Fang, C.C., S. Seaton and W. Shumway. 2007. Enhanced Thermal Desorption Process Can Extend Life of Base Oil And Reduce Energy Costs. S&P Environmental and Safety Conference, 5–7 March 2007, Galveston, Texas, USA SPE 106798.
- Getliff, J., A. Roach, J. Toyo and J. Carpenter. 1997. An Overview of the Environmental Benefits of LAO Based Drilling Fluids for Offshore Drilling. Report from Schlumberger Dowell. 10 pp.
- Getliff, J., A. Roach, J. Toyo and J. Carpenter. 1997. An Overview of the Environmental Benefits of LAO Based Drilling Fluids for Offshore Drilling. Report from Schlumberger Dowell. 10 pp. As cited by J.M. Neff, S.
- McKelvie and R.C. Ayers, Jr. 2000. Environmental Impacts of Synthetic Based Fluids. Report prepared by Rover Ayers & Associates, Inc. U.S. Department of the Interior, Minerals Management Service, Gulf of Mexico OCS Region, New Orleans, LA. OCS Study MMS, 200–064.
- Hall, J., S. Seaton and S. Visser, 2007. Optimizing fluid choices for land farm applications. International Petroleum Technology Conference, 4–6 December 2007, Dubai, U.A.E. IPTC 11237.
- Halliburton. 2007. Thermal desorption solutions data sheets. September 2007.
- Hart, R.A., S.J. Svedeman and F. Viana. 2007. Fall Velocity of Synthetic-Based Drilling Fluids in Seawater, Final Report. Prepared by Southwest Research Institute for the U.S. Department of the Interior, Minerals Management Service, Herndon, VA. SwRI® Project No. 18.12210.
- HMDC (Hibernia Management Development Company Limited). 2009. Hibernia Production Phase Environmental Effects Monitoring Program - Year Six (2007).
- Hurley & Ellis (2004). Environmental Effects of Exploratory Drilling Offshore Canada: Environmental Effects Monitoring Data and Literature Review. The Canadian Environmental Assessment Agency, RAC.
- Husky Exploration and Delineation Drilling Program for Jeanne d'Arc Basin Area EA (2007). <<http://www.cnlopb.nl.ca/pdfs/hejdarc/heearpt.pdf>>
- Hutchison Hayes. 2007. Environmental Cuttings Dryer System specifications from Hutchison Hayes Separation Inc. website (www.hutch-hayes.com).
- International Association of Oil & Gas Producers. 2003. Environmental Aspects of the Use and Disposal of Non Aqueous Drilling Fluids Associated with Offshore Oil & Gas Operations.
- Johnston et al. 2004. Controlling Synthetic-Based Drilling Fluid Discharges Through the Best Management Practices Compliance Alternative. SPE International Conference on Health, Safety and Environment in Oil and Gas Exploration and Production, 29–31 March 2004, Calgary, Alberta, Canada. SPE 86701.

Kirkness, A. and D. Garrick. 2008. Treatment of Nonaqueous-Fluid-Contaminated Drilling Cuttings – Raising Environmental Safety Standards. IADC/SPE Drilling Conference, 4–6 March 2008, Orlando Florida, USA IADC/SPE 112727.

MAPEM, 2004. MAPEM Project Environmental Monitoring of Offshore Drilling for Petroleum Exploration Offshore Brazil.

Mathieu, A., W. Melvin, B. French, M. Dawe, E.M. Deblois, F. Power and U.P. Williams. 2005. Health Effect Indicators in American plaice (*Hippoglossoides platessoides*) from the Terra Nova Development Site, Grand Banks, NL, Canada. Pp. 297–317. In: Offshore Oil and Gas Environmental Effects Monitoring: Approaches and Technologies. Edited by S.L. Armsworthy, P.J. Cranford and K. Lee. Batelle Press, Columbus, Ohio.

Melton et al. 2004. Environmental Aspects of the Use and Disposal of Non-Aqueous Drilling Fluids Associated with Offshore Oil & Gas Operations. SPE International Conference on Health, Safety and Environment in Oil and Gas Exploration and Production, 29–31 March 2004, Calgary, Alberta, Canada. SPE 86696.

MI-SWACO, 2008 Catalog, Environmental Solutions.

MMS (Minerals Management Service). 2000. Environmental Impacts of Synthetic Based drilling Fluids. U.S. Department of the Interior, Minerals Management Service, Gulf of Mexico Outer Continental Shelf Region. OCS Study MMS, 2000–164: 121 pp.

Morris R. and S. Seaton, 2006. Design and Testing of Bulk Storage Tanks for Drill Cuttings Offers Operators Safer Solution in Zero Discharge Operations. AADE Drilling Fluids Technical Conference, 11–12 April 2006, Houston, Texas, USA AADE-06-DF-HO-17.

Muddied Waters: A Survey of Offshore Oilfield Drilling Wastes and Disposal Techniques to Reduce the Ecological Impact of Sea Dumping (2000). <<http://www.alaskaforum.org/other/muddiedwaters.pdf>> .
Muherel, M.A. and R. Junin, 2007. Potential of surfactant washing to solve drilling waste environmental problems offshore. Emirates Journal for Engineering Research 12 (2): 1-10.

Murray, A.J., SPE and Kapila, SPE, M-I Swaco; G. Ferrari and Degouy, Agip; B.J. Espagne, Total and P. Handgraaf, Thermtech. 2008. Friction-Based Thermal Desorption Technology: Kashagan Development Project Meets Environmental Compliance in Drill Cuttings Treatment and Disposal.

National Energy Board, Canada-Newfoundland Offshore Petroleum Board, and Canada-Nova Scotia Offshore Energy Board. 2002. Offshore Waste Treatment Guidelines.

NEB, C-NLOPB and C-NSOPB (National Energy Board, Canada-Newfoundland Offshore Petroleum Board and Canada-Nova Scotia Offshore Petroleum Board). 2002. Offshore Waste Treatment Guidelines.

Neff, J.M. 2005. Composition, Environmental Fates and Biological Effects of Water-Based Drilling Muds and Cuttings Discharged to the Marine Environment: A Synthesis and Annotated Bibliography. Prepared for Petroleum Environmental Research Forum (PERF) and American Petroleum Institute, MA.

Norsk Hydro Canada Oil & Gas Inc. Pre-Development Activities Wellsite Geohazard Surveys Exploration and Delineation Drilling, 2006.

<<http://www.cnlopb.nl.ca/pdfs/nhexdp/nhpro01.pdf>>

Oil and Gas UK Environmental Legislation. 2008. OBM and SBM Use and Discharge.

Orphan Basin Exploration Drilling Program Project Description, 2004.

<<http://www.cnlopb.nl.ca/pdfs/orphan/projdesc.pdf>>

Orphan Basin Strategic Environmental Assessment, 2003.

<http://www.cnlopb.nl.ca/pdfs/ob_ea.pdf>

OSPAR Commission, 2002. Dynamic Selection and Prioritisation Mechanism for Hazardous Substances (DYNAMEC).

OSPAR Commission, 2006. Protocols on Methods for the Testing of Chemicals Used in the Offshore Oil Industry.

Page, Paul, W., SPE, Exploration Co., Ltd., Giles Segret, Total E & P UK; Johnson, David, Bradshaw, Keith, Lafarge Envirocem Solutions, Jones, Harry, Forkers Ltd. 2004. Stabilization of Oil Based Mud Drill Cuttings Used Accelerated Carbonation Technology.

Payne et al., DFO, 2001. Laboratory Exposures of Invertebrate and Vertebrate Species to Concentrations of IA-35 (Petro-Canada) Drill Mud Fluid, Production Water and Hibernia Drill Mud Cuttings.

Payne et al., DFO, 2006. Risks Associated with Drilling Fluids at Petroleum Development Sites in the Offshore: Evaluation for the Potential of an Aliphatic Hydrocarbon Based Drilling Fluid to Produce Sedimentary Toxicity and for Barite to Be Acutely Toxic to Plankton.

Pierce, D., C. Gaddis and B. Wood. 2006. Lessons Learned from Treating 500,000 Tons of Oil Based Drill Cuttings on Five Continents. IADC/SPE 99027.

Port au Port Bay Exploration Drilling Program Environmental Assessment, 2007.

<<http://www.cnlopb.nl.ca/pdfs/pdidrill/pdiearpt.pdf>>.

Quanxin Guo, SPE, Thomas Geehan, SPE, and Adriana Ovalle, SPE, M-I SWACO. 2007. Increased Assurance of Drill Cuttings Reinjection: Challenges, Recent Advances and Case Studies.

Robinson, J., S. Kingman, C. Snape, M. Bradley, S. Bradshaw, D. Thomas and P. Page. 2008. Microwave Treatment of Oil-Contaminated Drill Cuttings at Pilot Scale. SPE International Conference on Health, Safety and Environment in Oil and Gas Exploration and Production, 15–17 April 2008, Nice, France. SPE 111637.

S. Sayle, M. Seymour and E. Hickey, 2001 (SPE). Assessment of Environmental Impacts from Drilling Muds and Cuttings Disposal, Offshore Brunei.

Saintpere, S. and A. Morillon-Jeanmaire, 2000. Supercritical Co₂ Extraction Applied to Oily Drill Cuttings. SPE Annual Technical Conference and Exhibition, 1–4 October 2000, Dallas, Texas, USA SPE 63126.

Seaton, S. and J. Hall. 2005. Recovery of Oil from Drilled Cuttings by Liquefied Gas Extraction. SPE International Symposium on Oilfield Chemistry, 2–4 February 2005, Houston, Texas, USA.

Shang, H.C., E. Snape, S.W. Kingman and J.P. Robinson. 2005 Treatment of Oil-Contaminated Drill Cuttings by Microwave Heating in a High-Power Single Mode Cavity. *Ind. Eng.Chem Res* 44:6837–6844.

Society of Petroleum Engineers Inc., April 2008. Microwave Treatment of Oil-Contaminated Drill Cuttings at Pilot Scale.

Society of Petroleum Engineers Inc., February 2001. Chemical Treatment of Cuttings Drilled with Oil-Based Mud Employing a Laboratory Simulated Soil Washing Procedure.

Society of Petroleum Engineers Inc., January 2007. Increased Assurance of Drill Cuttings ReInjection: Challenges, Recent Advances and Case Studies

Society of Petroleum Engineers Inc., June 2000. Environmental Priorities of Re-Injection and Land-Based Handling of Drilled Cuttings and Affiliated Fluids.

Society of Petroleum Engineers Inc., June 2007. Environmentally Safe Waste Disposal: The Integration of Cuttings Collection, Transport and ReInjection.

Society of Petroleum Engineers Inc., March 2001. Silica Micro-Encapsulation Technology for Treatment of Oil and/or Hydrocarbon-Contaminated Drill Cuttings.

Society of Petroleum Engineers Inc., March 2003. The Characterization of Base Oil Recovered from the Low Temperature Thermal Desorption of Drill Cuttings.

Society of Petroleum Engineers Inc., March 2004. Environmental Aspects of the Use and Disposal of Non Aqueous Drilling Fluids Associated with Offshore Oil and Gas Operations.

Society of Petroleum Engineers Inc., March 2005. Managing Risks and Uncertainties in Drill Cuttings Re- Injection in Challenging Environments – Field Experience from Sakhalin Island.

Society of Petroleum Engineers Inc., March 2008. Treatment of Non Aqueous-Fluid-Contaminated Drill Cuttings – Raising Environmental and Safety Standards.

Society of Petroleum Engineers Inc., November 2007. Novel Service Approach Helps Operator Meet European Environmental Requirements, Reduce Waste Generation and Cut Costs.

Society of Petroleum Engineers Inc., September 2005. Exploration Drilling in the Barents Sea; Prevailing Zero Discharge Regime, Challenges and Learning from Recent Exploration Drilling.

Society of Petroleum Engineers Inc., September 2008. Friction-Based Thermal Desorption Technology: Kashagan Development Project Meets Environmental Compliance in Drill-Cuttings Treatment and Disposal.

Stephenson, R.L., S. Seaton, Halliburton Baroid, R. McCharen, E. Hernandez and R.B. Pair. 2004. Thermal Desorption of Oil from Oil-Based Drilling Fluids Cuttings: Processes and Technologies. SPE Asia Pacific Oil and Gas Conference and Exhibition, 18–20 October 2004, Perth Australia, SPE 88486.

Street, C.G., C. Tesche and S.E. Guigard. 2007. Treatment of Hydrocarbon-Based Drilling Waste Using Desorption of Oil from Oil-Based Drilling Fluids Cuttings: Processes and Technologies. SPE Asia Pacific Oil and Gas Conference and Exhibition, 18–20 October 2004, Perth, Australia. SPE 88486.

Tait et al., SPE, 2004. Impact Assessment and Benthic Recruitment Following Exploration Drilling in the South Caspian Sea.

Thermtech AS. 2008. Thermomechanical Cuttings Cleaner (TCC) commercial specifications and brochures.

TWMA website (2008) http://twma.co.uk/environmental_services.html

U.S. Environmental Protection Agency. 2000a. Development Document for Final Effluent Limitations Guidelines and Standards for Synthetic-Based Drilling Fluids and other Non-Aqueous Drilling Fluids in the Oil and Gas Extraction Point Source Category. EPA 821 B 00-013. December 2000. Washington, DC.

U.S. Environmental Protection Agency. 2000b. Environmental Assessment of Final Effluent Limitations Guidelines and Standards for Synthetic-Based Drilling Fluids and other Non-Aqueous Drilling Fluids in the Oil and Gas Extraction Point Source Category. EPA-821-B-00-014. December 2000. Washington, DC.

United States Environmental Protection Agency. 2003c. Clarification of Technology-Based Sediment Toxicity and Biodegradation Limitations and Standards for Controlling Synthetic-Based Drilling Fluid Discharges.

U.S. Environmental Protection Agency. 2000d. Economic Analysis of Final Effluent Limitations Guidelines and Standards for Synthetic-Based Drilling Fluids and other Non-Aqueous Drilling Fluids in the Oil and Gas Extraction Point Source Category. EPA-821-B-00-012. December 2000. Washington, DC.

Veil, J.A., 2001, "Offshore Waste Management – Discharge, Inject, or Haul to Shore?". 8th International Petroleum Environmental Conference, Houston, TX, November 6–9.

Wait, S.T., Oiltools (Europe) Limited; and Thomas, D., SPE, Amerada Hess Limited. 2003. The Characterization of Base Oil Recovered from the Low Temperature Thermal Desorption of Drill Cuttings.

White Rose Environmental Effects Monitoring Program 2005 (Volume 1), 2006. <http://www.huskyenergy.ca/downloads/AreasOfOperations/EastCoast/HSE/WhiteRose2005EEMReport_Vol1.pdf>

Wills, J, 2000. A Survey of Offshore Oilfield Drilling Wastes and Disposal Techniques to Reduce the Ecological Impact of Sea Dumping for Ekologicheskaya Vahkra Sakhalina (Sakhalin Environment Watch); May 25, 2000

APPENDIX A

INTERNATIONAL REQUIREMENTS FOR DISCHARGE OF DRILLING MUD & CUTTINGS

Appendix A. Requirements for Discharge of Drilling Mud and Cuttings				
Country	Water Based Drilling Fluids and Cuttings	Oil Based Drilling Fluid Cuttings	Synthetic Based Drilling Fluid Cuttings	Environmental Monitoring Requirements
Angola	<ul style="list-style-type: none"> • Discharge allowed 	<ul style="list-style-type: none"> • Cuttings discharge allowed; muds are reused. • Oil on cuttings measured; no limit provided. • No other parameters measured. • Group II NADF cuttings are discharged. 	<ul style="list-style-type: none"> • Cuttings discharge allowed; muds are reused. • Oil on cuttings measured. 	
Australia	<p>Discharge allowed subject to 1% oil limit, including free oil and diesel oil, and 17% KCl content of muds for exploratory drilling. Sampling required pre-discharge.</p> <ul style="list-style-type: none"> • Other drilling wastes can be discharged as long as they meet the 1% oil limit. • Risk assessments required by regulator. • Operators describe the types of muds to be used and may make commitments for additional testing or monitoring in environmental plans that are submitted to the government and once accepted become binding requirements. • Flow rate monitored but not reported or limited. • Some dischargers monitor Hg/Cd. 	<ul style="list-style-type: none"> • 1% oil limit effectively eliminates discharge. In W A, operators were allowed approx. 15% oil limit for low tox OBM cuttings 2–3 years ago. This exception would most likely not be allowed now. • Restriction on fluids with aromatics >1%. • At present, in Western Australia (WA) over 80% of all wells are drilled using WBF in all hole sections. The remaining wells are drilled using WBF for the top hole sections and non-WBF in the 311 mm (12 1/4 inch) and/or 216 mm (8 1/2 inch) bottom hole sections. The use of low toxicity OBF in the bottom hole sections has reduced from 10% of all wells drilled in 1994 to 0% (as of mid-1998). The use of SBF has remained essentially the same over the same period with increasing proportion of EBFs. Since the late 1980s, there has been a trend towards the increased use of more technically advanced WBFs. 	<ul style="list-style-type: none"> • No specific regulatory language concerning SBM. • WA regulator sets a 10% dry weight limit on SBM cuttings discharges under environmental plan regulations. • Operators have discharged esters and IO cuttings with requirements for monitoring programs determined on case by case basis. • Esters seem to be acceptable but more general acceptability of SBM not resolved. • Environmental regulations for offshore E&P being overhauled and may become more detailed and specific. • Enhanced-mineral-oil-based cuttings have been used in the past in WA and discharged. • Where the use of SBF is accepted, discharges to the seabed are limited to a maximum amount of 10% by dry weight of base fluid on drilled cuttings for a 311 mm (12 1/4 inch) hole size. 	<ul style="list-style-type: none"> • Monitoring not required but may be in the future. • Operators may make commitments for monitoring in environment plans that are submitted to the government and once accepted become binding requirements.

Appendix A. Requirements for Discharge of Drilling Mud and Cuttings

Country	Water Based Drilling Fluids and Cuttings	Oil Based Drilling Fluid Cuttings	Synthetic Based Drilling Fluid Cuttings	Environmental Monitoring Requirements
Azerbaijan	<ul style="list-style-type: none"> • Discharge allowed as long as low toxicity, acceptable biodegradability mud is used. • Chloride content limited to less than 4 (or 2 for some PSAs) times ambient – Caspian Sea is 1/3 seawater salinity. • Flow rate is estimated daily by drilling logs and reported monthly, but is not limited. • Periodic sampling for toxicity testing. • Before drilling, mud program is assessed for toxicity and biodegradability. • Chloride content is monitored. • Daily inventory of discharged mud additives is maintained. • Operators in inshore/ environmentally sensitive areas have more monitoring requirements and more stringent standards. • Regulators like to see MSDS for all chemicals that can be used, but no certification process for each chemical. 	<ul style="list-style-type: none"> • No discharge of fluid or cuttings. • Injection of cuttings being planned for exploration wells. • Onshore treatment (e.g., fixation) and/or landfilling being planned. • Some operators treat cuttings onshore; 	<ul style="list-style-type: none"> • Cuttings from synthetics may be discharged. Voluntary commitments by BP Amoco to no discharge of synthetic cuttings. Operators expect further restrictions, primarily on production drilling. • No discharge of SBM fluids. • Discharge of cuttings allowed as long as a low toxicity, acceptable biodegradability mud is used. • Some operators have a limit of 10% SBM fluid on cuttings. • Discharge of enhanced-mineral-oil-based fluids is not allowed, discharge of cuttings anticipated to be allowed as long as fluids have low toxicity and acceptable biodegradability standards have not been set. 	<ul style="list-style-type: none"> • Monitoring requirements are negotiated by each operator as part of the PSA, or through the EIA. • Operators are required to conduct baseline surveys prior to commencing operations (both exploration and production). • Post drilling surveys are required as well and are proposed in the EIA. • Operational monitoring of discharges negotiated by each operator as part of PSA.

Appendix A. Requirements for Discharge of Drilling Mud and Cuttings

Country	Water Based Drilling Fluids and Cuttings	Oil Based Drilling Fluid Cuttings	Synthetic Based Drilling Fluid Cuttings	Environmental Monitoring Requirements
Bahrain	<ul style="list-style-type: none"> • May be discharged but cannot "contain persistent systematic toxins" 	<ul style="list-style-type: none"> • Use of Group I (oil/diesel/mineral oils PAH 2.4% Aromatics 25% - high) and Group II (LTMO's PAH 0.001-0.35%. Aromatics 0.5-5% - medium) fluids requires express sanction of the competent state authority. • No whole Group I and Group II fluids can be discharged. • No Group I and Group II (including diesel) cuttings should be discharged except in exceptional circumstances. • Express sanction is requested for discharge of Group II drill cuttings. • No drill cuttings should be deposited on the seabed in a sensitive area without the express sanction of the competent state authority. 	<ul style="list-style-type: none"> • Group III (SBMs, esters, paraffins, olefins, PAH < 0.001%, Aromatic < 0.5% - low) – Not addressed 	

Appendix A. Requirements for Discharge of Drilling Mud and Cuttings

Country	Water Based Drilling Fluids and Cuttings	Oil Based Drilling Fluid Cuttings	Synthetic Based Drilling Fluid Cuttings	Environmental Monitoring Requirements
Brazil	<ul style="list-style-type: none"> • No specific regulatory language concerning WBF. • Current practice is to allow discharge. 	<ul style="list-style-type: none"> • All drilling discharge plans need to be approved through IBAMA. IBAMA has made it clear that there will be greater scrutiny of NAF discharges (than those of WBFs). • OBM not permitted for discharge. • Unlikely that low tox mineral oils would be approved; enhanced mineral oil based fluids possible. • Petrobras currently discharging a highly refined paraffin mud. 	<ul style="list-style-type: none"> • SBM cuttings have been discharged by Petrobras. • Industry workgroup formulated guidelines for discharge approval (laboratory testing protocols for biodegradability, sediment toxicity and bioaccumulation) and worked with government to develop a framework for obtaining approval for use of synthetics. • Zero discharge in < 60 m water depth and environmentally sensitive areas; monitoring requirements that vary by depth; > 1,000 m: no monitoring required; 60 m–1,000 m: comprehensive water column and seabed monitoring; NADF (SBM) cuttings permitted for discharge in water depths > 60 m subject to pre and post drill toxicity tests on organisms from four different phyla and lab tests of NABF for biodegradation (OECD 306 method), total PAH concentration, and bioaccumulation potential (log Pow); average < 9.4% ROC for ester, average < 6.9% ROC for paraffin/olefin, Hg/Cd in barite < 1/3 mg/kg; < 1% formation oil (by RPE). 	

Appendix A. Requirements for Discharge of Drilling Mud and Cuttings

Country	Water Based Drilling Fluids and Cuttings	Oil Based Drilling Fluid Cuttings	Synthetic Based Drilling Fluid Cuttings	Environmental Monitoring Requirements
Canada	<ul style="list-style-type: none"> • The 2002 Offshore Waste Treatment Guidelines allow the discharge of water based muds without restrictions but encourage operators to reduce the need for bulk disposal of drilling fluids. • Discharge of drill cuttings associated with WBM is also permitted. 	<ul style="list-style-type: none"> • 2002 Offshore Waste Treatment Guidelines require approval by the Chief Conservation Officer for the use of OBM when it is not technically feasible to use WBM or SBMs. • This only occurs under exceptional circumstances and at no time can whole OBM be discharged to sea. • The Chief Conservation Officer may grant approval for the use of enhanced mineral oil based muds (EMOBM), provided it is environmental, and safety performance can be demonstrated to be equivalent or better than SBM. • Whole EMOBM are not permitted to be discharged at sea, instead they must be recovered and recycled, re-injected, or transferred to shore to be treated and disposed of using an approved method. • Drill cuttings associated with OBM are not permitted to be disposed of at sea; however drill cuttings associated with EMOBM are permitted to be disposed of at sea provided they have been treated with best available technology to achieve an oil on cuttings retention limit of 6.9% wet weight. 	<ul style="list-style-type: none"> • 2002 Offshore Waste Treatment Guidelines require SBMs to have a PAH concentration of < 10 mg/kg and be able to biodegrade under aerobic conditions. • Whole SBM are not permitted to be discharged at sea, instead they must be recovered and recycled, re-injected, or transferred to shore to be treated and disposed of using an approved method and must have a PAH content of < 10 mg/kg. • Drill cuttings associated with SBMs are to be re injected and where this option may not be technically feasible, the cuttings may be discharged at sea provided they have been treated first with the best available technology (BAT) first to achieve an oil on cuttings retention limit of 6.9% wet weight. 	<ul style="list-style-type: none"> • Environmental effects and compliance monitoring is required for production drilling per the Offshore Waste Treatment Guidelines.

Appendix A. Requirements for Discharge of Drilling Mud and Cuttings

Country	Water Based Drilling Fluids and Cuttings	Oil Based Drilling Fluid Cuttings	Synthetic Based Drilling Fluid Cuttings	Environmental Monitoring Requirements
China	<ul style="list-style-type: none"> • Discharge allowed. • Use of oil shall be avoided or minimized. • Prior to discharge, the operator shall notify the relevant agency of oil containing water-based drilling fluids and submit sample. • If oil content is > 10%, discharge not allowed. • If oil content is < 10% and further recovery difficult, upon relevant agency approval, discharge is allowed, but operator shall pay a discharge fee. • Prior to discharge, dispersant shall not be mixed with oil-containing water-based fluids for treatment. • No KCl restrictions known. • Flow rate measurements are at the discharge pipe and daily monitoring is the responsibility of the environmental monitoring office of the operator. Flow rate limits unknown. • Other monitoring requirements for other drilling fluid components unknown. • Discharge of residual oil, waste oil, oil-containing waste and its residual liquids and solids are prohibited. These wastes shall be stored in special containers for shipment to shore. • Operator shall record in the Antipollution Record Book drilling mud, oil content of cuttings, time of discharge, and volume of discharge. 	<ul style="list-style-type: none"> • Discharge of OBM cuttings allowed; fluids not allowed. • If oil content is >10%, discharge not allowed. • If oil content is <10% and further recovery is difficult, discharge allowed after approval from relevant agency, but operator shall pay a discharge fee. 	<ul style="list-style-type: none"> • Regulations regarding discharge of SBM fluid/cuttings unknown. • Government encouraging the use of low toxicity fluid. Minor volumes, when recovery is not possible, may be discharged subject to an appropriate discharge fee. 	<ul style="list-style-type: none"> • No drilling monitoring requirements for exploratory drilling.

Appendix A. Requirements for Discharge of Drilling Mud and Cuttings

Country	Water Based Drilling Fluids and Cuttings	Oil Based Drilling Fluid Cuttings	Synthetic Based Drilling Fluid Cuttings	Environmental Monitoring Requirements
Congo	<ul style="list-style-type: none"> • Use and discharge allowed 	<ul style="list-style-type: none"> • Use and discharge allowed, except for diesel-based drilling fluids and associated cuttings. • Authorities request that cuttings be subject to mechanical treatment in order to reduce amount of fluid discharged. 	<ul style="list-style-type: none"> • No specific requirements 	
Denmark	<ul style="list-style-type: none"> • Discharge allowed subject to pre-approval requirements for drilling fluid chemicals 	<ul style="list-style-type: none"> • Discharged allowed with limit of 1% oil on cuttings, which is not operationally attainable with current technology. 	<ul style="list-style-type: none"> • Considered on a case by case basis but no use at present. 	
Equatorial Guinea	<ul style="list-style-type: none"> • Discharge allowed 	<ul style="list-style-type: none"> • Discharge allowed 	<ul style="list-style-type: none"> • Discharge allowed • Operators currently discharging EMBF (Certrex 67 special) 	
France	<ul style="list-style-type: none"> • Use and discharge allowed (permit required) 	<ul style="list-style-type: none"> • Under OSPAR 2000/3, discharge is subject to limit of 1% oil on cuttings, which is not operationally attainable with current technology. • It is expected that authorities will not grant any more discharge permits for the Northeast Atlantic or Mediterranean Sea. 	<ul style="list-style-type: none"> • Under OSPAR 2000/3, cuttings contaminated with synthetic fluids may only be discharged in exceptional circumstances. • It is expected that authorities will not grant any more discharge permits for the Northeast Atlantic or Mediterranean Sea. 	
Gabon	<ul style="list-style-type: none"> • Use and discharge allowed 	<ul style="list-style-type: none"> • Use and discharged allowed, except for diesel based drilling fluids and associated cuttings. • Authorities request that cuttings be subject to mechanical treatment in order to reduce amount of fluid discharged. 	<ul style="list-style-type: none"> • No specific requirements 	

Appendix A. Requirements for Discharge of Drilling Mud and Cuttings

Country	Water Based Drilling Fluids and Cuttings	Oil Based Drilling Fluid Cuttings	Synthetic Based Drilling Fluid Cuttings	Environmental Monitoring Requirements
Iran	<ul style="list-style-type: none"> • May be discharged but cannot “contain persistent systematic toxins” 	<ul style="list-style-type: none"> • Use of Group I and Group II requires express sanction of the competent state authority. • No whole Group I and Group II fluids can be discharged. • No Group I and Group II (including diesel) cuttings should be discharged except in exceptional circumstances. • Express sanction is requested for discharge of Group II drill cuttings. • No drill cuttings should be deposited on the seabed in a sensitive area without the express sanction of the competent state authority. 		
Italy	<ul style="list-style-type: none"> • Discharge allowed following suitable regulatory authorization 	<ul style="list-style-type: none"> • Discharged allowed at less than 10% oil on cuttings. • Discharge not permitted in Adriatic Sea. 	<ul style="list-style-type: none"> • Not considered under current (2003) regulations 	
Kazakhstan	<ul style="list-style-type: none"> • No discharge allowed per the Petroleum Law; Environmental Protection Norms (for offshore, coastal areas and internal water bodies); and Special Ecological Requirements (for State Nature Preserve Zone in North Caspian). 	<ul style="list-style-type: none"> • No discharge allowed per the Petroleum Law; Environmental Protection Norms (for offshore, coastal areas and internal water bodies); and Special Ecological Requirements (for State Nature Preserve Zone in North Caspian). • OKIOC presently using ITOBM and hauling cuttings ashore for thermal desorption and fluid recovery. 	<ul style="list-style-type: none"> • No discharge allowed per the Petroleum Law; Environmental Protection Norms (for offshore, coastal areas & internal water bodies); and Special Ecological Requirements (for State Nature Preserve Zone in North Caspian). 	<ul style="list-style-type: none"> • Operators are required to conduct baseline surveys prior to commencing operations. • Monitoring requirements are stated in regulations and further negotiated by each operator through the EIA process. • Post drilling surveys are required for 2 consecutive years. • Monitoring requirements stated in regs but are negotiable.

Appendix A. Requirements for Discharge of Drilling Mud and Cuttings

Country	Water Based Drilling Fluids and Cuttings	Oil Based Drilling Fluid Cuttings	Synthetic Based Drilling Fluid Cuttings	Environmental Monitoring Requirements
Malaysia	<ul style="list-style-type: none"> • Discharge allowed. • Flow rate is estimated but not reported. • Drilling mud makeup is monitored but not reported. • No additional monitoring requirements. 	<ul style="list-style-type: none"> • Discharged allowed. • No oil limit. • Operators are using Group II NADFs and discharging cuttings. 	<ul style="list-style-type: none"> • Operators are using refined paraffins and low toxicity OBM and discharging cuttings. No regulatory action on SBM currently on horizon. • No oil limit. 	<ul style="list-style-type: none"> • No drilling monitoring requirements; voluntary environmental monitoring sometimes conducted as part of the EIA approval process. • One-time baseline study of a new field area as part of EIA preparation.
Netherlands	<ul style="list-style-type: none"> • Discharge allowed subject to pre-approval requirements for drilling fluid chemicals. Pre-approval requirements include toxicity testing according to OSPAR protocols. 	<ul style="list-style-type: none"> • Under OSPAR 2000/3, discharge is subject to limit of 1% oil on cuttings, which is not operationally attainable with current technology. 	<ul style="list-style-type: none"> • Under OSPAR 2000/3, cuttings contaminated with synthetic fluids may only be discharged in exceptional circumstances. • Extensive monitoring requirements effectively prohibit use. 	

Appendix A. Requirements for Discharge of Drilling Mud and Cuttings

Country	Water Based Drilling Fluids and Cuttings	Oil Based Drilling Fluid Cuttings	Synthetic Based Drilling Fluid Cuttings	Environmental Monitoring Requirements
Nigeria	<ul style="list-style-type: none"> • To discharge, must submit proof that mud has low toxicity to Director of Petroleum Resources (DPR) with permit application. Discharges will be treated to DPR's satisfaction. • DPR will examine WBM to determine how hazardous and toxic it is. • Cuttings contaminated with WBM may be discharged offshore/ deep water without treatment. • See Appendix III for monitoring requirements. • See Appendix III for Generic Drilling Fluids List showing components of drilling fluids that are regulated. 	<ul style="list-style-type: none"> • To discharge, must submit proof that OBM has low toxicity to DPR with permit application. Discharges will be treated to DPR's satisfaction. • OBM must be recovered, reconditioned and recycled. • Oil on cuttings, 1% with 0% goal. • On-site disposal if oil content does not cause sheen on the receiving water. • Cuttings samples shall be analysed by Operator as specified by DPR once a day. • Point of discharge as designated on the installation by shunting to the bottom. • DPR to analyse samples at its own discretion for toxic/hazardous substances. • Operator to carry out first post-drilling seabed survey 9 months after 5 wells have been drilled. Subsequent seabed surveys shall then be carried out after a further 18 months or further 10 wells. • Operator must submit to DPR details of sampling and analysis records within 2 weeks of completion of any well. • Inspection of operations shall be allowed at all reasonable times. 	<ul style="list-style-type: none"> • SBM must be recovered, re-conditioned, and recycled. • SBM cuttings must contain 5% drilling fluid or less for discharge. (10% for esters) • Special provision for higher retention limits has been granted for some deepwater wells. • Discharge prohibited in swamp areas. • DPR is considering special considerations for exploration drilling and drilling in deep water. 	<ul style="list-style-type: none"> • Operator to carry out first post drilling seabed survey after 9 months or after 5 wells have been drilled, whichever is shorter. Subsequent seabed surveys shall than be carried out after a further 19 months or 10 wells.

Appendix A. Requirements for Discharge of Drilling Mud and Cuttings

Country	Water Based Drilling Fluids and Cuttings	Oil Based Drilling Fluid Cuttings	Synthetic Based Drilling Fluid Cuttings	Environmental Monitoring Requirements
North Sea	<ul style="list-style-type: none"> • Discharge of WBM is permitted given that the oil content is less than 1% by weight and that it has passed toxicity testing under OSPAR 2000/3. • Persistency (P): Half-life (T_{1/2}) of 50 days and • Liability to Bio-accumulate (B): log Kow ≥ 4 or BCF ≥ 500 and • Toxicity (T) Taq: acute L(E)C50 < 1 mg/l, long-term NOEC < 0.1 mg/l 	<ul style="list-style-type: none"> • The discharge of OBM on cuttings is limited to 1% by weight. 	<ul style="list-style-type: none"> • The discharge of SBM on cuttings exceeding 1% SOC is only permitted under exceptional circumstances. 	
Norway	<ul style="list-style-type: none"> • Discharge allowed subject to pre-approval requirements for all drilling fluid chemicals. • Monitoring of discharge sites may be required. Pre approval requirements include toxicity testing according to OSPAR protocols. • No KCl limits. • Flow rate not monitored or limited, but calculation is made of cuttings discharged based on well dimensions and washout factor. • Sampling is daily. • Discharge of other drilling wastes not prohibited as long as pre-approval occurs. • A discharge permit is required for cementing and completion chemicals. • Drilling must makeup is monitored and reported. 	<ul style="list-style-type: none"> • Under OSPAR 2000/3, discharge is subject to limit of 1% oil on cuttings, which is not operationally attainable with current technology. 	<ul style="list-style-type: none"> • Permitting discharge of a range of synthetics for development drilling only. • SBM discharge allowed only where technical/safety considerations preclude use of WBM. • SBM content of cuttings limited to 8–18%; operator is required to set limit based on properties of formation. • Chemical monitoring of cuttings required annually; biological monitoring required every 3 years. • Applications for approval require testing according to OSPAR format. • OSPAR decision 2000/3 permits Group III cuttings discharge only under exceptional circumstances (for Norway, likely to mean only at those sites where SBFs have been previously discharged. 	<ul style="list-style-type: none"> • A baseline survey is required prior to initiation of production drilling activities. • Monitoring activities are thereafter required to be performed every 3 years. Surveys involve sampling of sediment and analysis for biological and chemical properties. • Guidelines for monitoring are provided in the 1999 SFT document "Environmental monitoring of petroleum activities on the Norwegian shelf guidelines" (in Norwegian). • Guidelines for characterizing drill cuttings piles have been prepared by the Norwegian oil industry association (OLF).

Appendix A. Requirements for Discharge of Drilling Mud and Cuttings

Country	Water Based Drilling Fluids and Cuttings	Oil Based Drilling Fluid Cuttings	Synthetic Based Drilling Fluid Cuttings	Environmental Monitoring Requirements
Oman	<ul style="list-style-type: none"> • May be discharged but cannot "contain persistent systematic toxins" 	<ul style="list-style-type: none"> • Use of Group I and Group II requires express sanction of the competent state authority. • No whole Group I and Group II fluids can be discharged. • No Group I and Group II (including diesel) cuttings should be discharged except in exceptional circumstances. • Express sanction is requested for discharge of Group II drill cuttings. • No drill cuttings should be deposited on the seabed in a sensitive area without the express sanction of the competent state authority. 		
Qatar	<ul style="list-style-type: none"> • May be discharged but cannot "contain persistent systematic toxins" 	<ul style="list-style-type: none"> • Use of Group I and Group II requires express sanction of the competent state authority. • No whole Group I and Group II fluids can be discharged. • No Group I and Group II (including diesel) cuttings should be discharged except in exceptional circumstances. • Express sanction is requested for discharge of Group II drill cuttings. • No drill cuttings should be deposited on the seabed in a sensitive area without the express sanction of the competent state authority. 	<ul style="list-style-type: none"> • Not addressed 	

Appendix A. Requirements for Discharge of Drilling Mud and Cuttings

Country	Water Based Drilling Fluids and Cuttings	Oil Based Drilling Fluid Cuttings	Synthetic Based Drilling Fluid Cuttings	Environmental Monitoring Requirements
Russia-Sakhalin Island	<ul style="list-style-type: none"> • In Russia’s Exclusive Economic Zone (beyond 12 mile Territorial Sea of Russia), control of all discharges is through the application of receiving water criteria or “maximum permissible concentrations” (MPCs). All substances discharged must have certified MPCs and must meet these allowable concentrations at a distance of 250 m from the discharge point. The promulgation, in 1998, of the Law on the Territorial Sea introduced uncertainty regarding the legality of ANY discharges within the 12 mile limit, at least in the minds of some Russian regulators. The government of the Russian Federation is taking steps to clarify the legal basis for discharges to the Territorial Sea (Decree by former President Putin). • Toxicity testing on mud additives, lab formulated muds and used muds using protozoa, marine algae, acartia and guppy at 20% salinity. Sampling frequency not specified several times during drilling. • Mud constituents, discharge rates, and other parameters may be regulated by the Water-use Licence process. 	<ul style="list-style-type: none"> • Regulatory documents do not deal specifically with oil based drilling fluids; regulations currently in draft form will prohibit cuttings discharge if oil based mud used. 	<ul style="list-style-type: none"> • Not yet discussed with regulators 	

Appendix A. Requirements for Discharge of Drilling Mud and Cuttings

Country	Water Based Drilling Fluids and Cuttings	Oil Based Drilling Fluid Cuttings	Synthetic Based Drilling Fluid Cuttings	Environmental Monitoring Requirements
Saudi Arabia	<ul style="list-style-type: none"> • May be discharged but cannot “contain persistent systematic toxins” 	<ul style="list-style-type: none"> • Use of Group I and Group II requires express sanction of the competent state authority. • No whole Group I and Group II fluids can be discharged. • No Group I and Group II (including diesel) cuttings should be discharged except in exceptional circumstances. • Express sanction is requested for discharge of Group II drill cuttings. • No drill cuttings should be deposited on the seabed in a sensitive area without the express sanction of the competent state authority. 	<ul style="list-style-type: none"> • Not addressed 	
Spain	<ul style="list-style-type: none"> • Use and discharge allowed (permit required) 	<ul style="list-style-type: none"> • Under OSPAR 2000/3, discharge is subject to limit of 1% oil on cuttings, which is not operationally attainable with current technology. • It is expected that authorities will not grant any more discharge permits for the Northeast Atlantic or Mediterranean Sea. 	<ul style="list-style-type: none"> • Under OSPAR 2000/3, cuttings contaminated with synthetic fluids may only be discharged in exceptional circumstances. • It is expected that authorities will not grant any more discharge permits for the Northeast Atlantic or Mediterranean Sea. 	
Thailand		<ul style="list-style-type: none"> • Discharge allowed if <10% oil on cuttings. Regulators are reviewing existing practices 	<ul style="list-style-type: none"> • No specific language concerning Group III NADFs. 	
The Netherlands	<ul style="list-style-type: none"> • Discharge allowed subject to pre-approval requirements for drilling fluid chemicals. Pre-approval requirements include toxicity testing according to OSPAR protocols. 	<ul style="list-style-type: none"> • Limit of 1% oil on cuttings—effectively prohibits discharge. 	<ul style="list-style-type: none"> • Extensive monitoring requirements effectively prohibit use. • Under OSPAR 2000/3, cuttings contaminated with synthetic fluids may only be discharged in exceptional circumstances. 	

Appendix A. Requirements for Discharge of Drilling Mud and Cuttings

Country	Water Based Drilling Fluids and Cuttings	Oil Based Drilling Fluid Cuttings	Synthetic Based Drilling Fluid Cuttings	Environmental Monitoring Requirements
Trinidad	<ul style="list-style-type: none"> • No specific restrictions against offshore discharge and has historically been allowed. • Use must be disclosed in EIA, which is approved by the Ministry of Energy. • Impact of Water Pollution Rules currently being promulgated by EMA is uncertain at this time; will likely allow discharge. 	<ul style="list-style-type: none"> • No specific restrictions against, but offshore discharge unlikely to be allowed by Ministry of Energy (MOE) during EIA approval process. • No offshore wells have been drilled with OBM in several years, so Ministry of Energy's stance has not been recently tested. • Impact of Water Pollution Rules currently being promulgated by EMA is uncertain at this time; will likely not allow discharge. 	<ul style="list-style-type: none"> • No specific restrictions against offshore discharge and has historically been allowed. • Impact of Water Pollution Rules currently being promulgated by EMA is uncertain at this time. 	
UAE	<ul style="list-style-type: none"> • May be discharged but cannot "contain persistent systematic toxins" 	<ul style="list-style-type: none"> • Use of Group I and Group II requires express sanction of the competent state authority. • No whole Group I and Group II fluids can be discharged. • No Group I and Group II (including diesel) cuttings should be discharged except in exceptional circumstances. • Express sanction is requested for discharge of Group II drill cuttings. • No drill cuttings should be deposited on the seabed in a sensitive area without the express sanction of the competent state authority. 	<ul style="list-style-type: none"> • Not addressed 	

Appendix A. Requirements for Discharge of Drilling Mud and Cuttings

Country	Water Based Drilling Fluids and Cuttings	Oil Based Drilling Fluid Cuttings	Synthetic Based Drilling Fluid Cuttings	Environmental Monitoring Requirements
UK	<ul style="list-style-type: none"> • Discharge allowed subject to pre-approval requirements for drilling fluid chemicals. Pre-approval requirements include toxicity testing according to OSPAR protocol. 	<ul style="list-style-type: none"> • Limit of 1% oil on cuttings effectively prohibits discharge • Practice is to inject cuttings or return to shore and recover oil. 	<ul style="list-style-type: none"> • Phasing out use of all but ester based synthetics. Industry expects further restrictions on esters. Discharge of non-ester fluids will likely cease at end of 2000. • However, OSPAR 200/3 decision permits Group III cuttings discharge only under exceptional circumstances. • The UK government has made it clear that there will be no exceptional circumstances arising that would lead to discharge of SBM cuttings. 	<ul style="list-style-type: none"> • OSPAR requirements • Requirements for seabed monitoring following discharge of SBM cuttings; data used in conjunction with laboratory data to determine fluid acceptability.
United States California (EUSA)	<ul style="list-style-type: none"> • Discharge allowed beyond coastal waters (3 mi). • 50lb/bbl in EPA generic mud #1. • Flow rate is monitored and maximum annual discharge cannot exceed 215,000 bbl. • Hg/Cd <1/2 ppm. • No free oil/diesel/waste oil as by static sheen test. • No chrome lignosulfonate. • 96 hr LC50 SPP >3%. Weekly sampling; at least 1 tox. Test of each mud system. Mud sample must be at 80% or greater of final depth for each mud system. • Special restrictions for environmentally sensitive areas. • Spotting fluids must meet toxicity requirements. • Drilling mud makeup monitored and reported. 	<ul style="list-style-type: none"> • Discharge prohibited. • Discharge of enhanced-mineral-oil-based mud/cuttings prohibited. • Practice is to inject OBM cuttings. 	<ul style="list-style-type: none"> • Not specifically mentioned in current permit; under discussion for regional permit. 	

Appendix A. Requirements for Discharge of Drilling Mud and Cuttings

Country	Water Based Drilling Fluids and Cuttings	Oil Based Drilling Fluid Cuttings	Synthetic Based Drilling Fluid Cuttings	Environmental Monitoring Requirements
United States GOM (EUSA)	<ul style="list-style-type: none"> • Discharge allowed > 3 miles, not allowed < 3 miles. • Toxicity limit effectively limits KCl content. • Flow rate is estimated hourly during discharge. • Flow rate is estimated hourly during discharge. • Flow rate is limited in biologically sensitive areas. • Toxicity: 96 hour LC50 of suspended particulate phase > 30,000 ppm. • 1/3 ppm Hg/Cd in barite; tested in stock barite. • Must keep a chemical inventory and track mass/volume of all mud constituents. • No free oil as measured by static sheen test. • Toxicity testing monthly. By Exxon choice, testing every time mud system changed. Static sheen testing is performed weekly. • Spotting pills may not be discharged. • No other components regulated. 	<ul style="list-style-type: none"> • Discharge not allowed. • OBM cuttings are typically landfilled. • Exxon typically rents OBM; pays for the volume that is not returned. Cuttings are treated to carrying degrees onshore and either injected or landfilled. 	<ul style="list-style-type: none"> • GOM allows discharge of SBM cuttings subject to essentially the same restrictions as water based mud. • Eastern GOM additional restriction of no discharges within 1,000 m of Areas of Biological Concern and ocean disposal sites. • Central and Western GOM additional restriction of no discharges within Areas of Biological Concern and controls the discharge rate within 544 m of these areas. • Only mud associated with cuttings may be discharged. Currently, spills of SBM are treated as oil spills. 	<ul style="list-style-type: none"> • Compliance monitoring as detailed. No requirements for routine scabbed monitoring.

Appendix A. Requirements for Discharge of Drilling Mud and Cuttings

Country	Water Based Drilling Fluids and Cuttings	Oil Based Drilling Fluid Cuttings	Synthetic Based Drilling Fluid Cuttings	Environmental Monitoring Requirements
United States	<ul style="list-style-type: none"> • Coastal Waters: (e.g., inland canals and enclosed bays). Discharge prohibited except for Alaska. Alaskan coastal waters subject to same regulations as offshore waters. • Offshore Water: Discharge allowed subject to: <ul style="list-style-type: none"> • > 3 mi from shore (except Alaska where > 3 mi restriction does not apply). • Limit of Hg/Cd in barite (1/3 ppm) • No free oil (static sheen test) • No diesel oil • Discharge rate < 1000 bbl/hr • Further restriction on rate in areas of special biological sensitivity. 	<ul style="list-style-type: none"> • Discharge prohibited 	<ul style="list-style-type: none"> • Current status • Central and Western GOM: Central and Western GOM additional restriction of no discharges within Areas of Biological Concern and controls the discharge rate within 544 m of these areas. • Eastern GOM: Eastern GOM additional restriction of no discharges within 1,000 m of Areas of Biological Concern and ocean disposal sites. • California: Discharges not allowed. • Alaska: Discharges not allowed. • EPA developing specific guidelines for SBM cuttings discharge. 	
Vietnam	<ul style="list-style-type: none"> • Discharge allowed. • No stipulations on KCI • Toxicity requirements not stipulated concretely. • In general, oil content should be lower than 1%. • Any use of drilling fluids, toxic and/or hazardous chemicals must be approved by regulatory agency in advance. • Drilling mud makeup is monitored and reported as drilling mud components in EIA report. 	<ul style="list-style-type: none"> • Discharge prohibited < 3 nautical miles. 1% oil limit (possibly extended in certain cases) for areas beyond 3 nautical miles. • Use of diesel-based drilling fluids is totally prohibited. 	<ul style="list-style-type: none"> • No stipulations regarding SBM cuttings. May have same restrictions as OBM cuttings. 	<ul style="list-style-type: none"> • Drilling monitoring requirements are only generally stipulated. • Operator must carry out environmental monitoring and implementation of a program of environmental supervision in accordance with the Ministry of Science, Technology and Environment (MOSTE) decision approving the EIA of a project or facility. • Monitoring requirements such as baseline and impact assessment studies are carried out as stipulated in the proposed and approved EIA.

APPENDIX B

SUMMARY OF RECENT MUD AND CUTTINGS OFFSHORE DISCHARGE EEM STUDIES

SUMMARY OF RECENT (POST-2001) EEM RESULTS

The study team undertook a review of various studies and environmental effects monitoring (EEM) programs that have been published since the previous CAPP (2001) background document on offshore drilling mud and cuttings discharges. Continental Shelf Associates Inc. (CSA), based in Florida, USA, provided a significant contribution to this assessment.

In order to summarize the vast amount of data and update current knowledge on this subject, the team focused on the following 10 recent and key representative papers/studies:

- ✦ White Rose Environmental Effects Monitoring Program: 2005–2006 Results (Husky Energy, 2006, 2007)
- ✦ US Minerals Management Service (MMS) Study of the Effects of Oil and Gas Exploration and Development at Selected Continental Slope Sites in the Gulf of Mexico (CSA, 2006)
- ✦ Risks Associated with Drilling Fluids at Petroleum Development Sites in the Offshore: Evaluation for the Potential of an Aliphatic Hydrocarbon Based Drilling Fluid to Produce Sedimentary Toxicity and for Barite to Be Acutely Toxic to Plankton (Payne et al., DFO, 2006)
- ✦ Environmental Effects of Exploratory Drilling Offshore Canada: Environmental Effects Monitoring Data and Literature Review – Final Report (Hurley and Ellis, 2004)
- ✦ Gulf of Mexico Comprehensive Synthetic Based Muds Monitoring Program (CSA, 2004)
- ✦ MAPEM Project Environmental Monitoring of Offshore Drilling for Petroleum Exploration Offshore Brazil (MAPEM, 2004)
- ✦ Impact Assessment and Benthic Recruitment Following Exploration Drilling in the South Caspian Sea (Tait et al., SPE, 2004)
- ✦ Environmental Aspects of the Use and Disposal of Non-Aqueous Drilling Fluids Associated with Offshore Oil & Gas Operations (OGP, 2003)
- ✦ Assessment of Environmental Impacts from Drilling Muds and Cuttings Disposal Offshore Brunei (Sayle et al., SPE, 2002)
- ✦ Laboratory Exposures of Invertebrate and Vertebrate Species to Concentrations of IA-35 (Petro-Canada) Drill Mud Fluid, Production Water and Hibernia Drill Mud Cuttings (Payne et al., DFO, 2001)

These reports represent a total of over 100 well site studies, the key findings of which are summarized below.

Summary of Recent Mud and Cuttings Offshore Discharge EEM Studies

<p>Study: White Rose Environmental Effects Monitoring Program: 2005–2008 Results (Husky Energy, 2006, 2007, 2008)</p>	<p>Description: The White Rose oilfield is 350 km east–southeast of St. John’s, Newfoundland. Water depths range from about 118 m to 123 m. As part of the Environmental Impact Statement (EIS) for the project, Husky Energy committed to a comprehensive Environmental Effects Monitoring (EEM) Program. Baseline sampling was conducted in 2000 and 2002, and EEM surveys were conducted in 2004, 2005, 2006 and 2008. Up to the time of the 2006 survey, the following drilling discharges had been made: WBM Cuttings (7,198,338 MT); WBM (10,433 m³); SBM Cuttings (18,247 MT); SBM (1,947 m³); and completion fluids (3,149 m³). The 2008 report integrates all of the findings to date. The White Rose EEM focused on sediment quality and commercial fish species. Sediment quality studies focused on chemical and physical characteristics, sediment toxicity and assessment of benthic community structure. Commercial fish studies included measurement of body burden, taint, morphometric and life history characteristics for a common flatfish species (American plaice) and a commercial shellfish species (snow crab), and measurement of various health indices for American plaice. The number of sediment stations varied among years: 48 in 2000 (baseline), 56 in 2004, 44 in 2005, 59 in 2006, and 47 in 2008; however, 37 stations were common to all surveys. The EEM program included reference stations at 28 km from the centre of the development, one station along the north axis at approximately 8 km from the centre of the development, and transects radiating from the three drill centre stations (Northern, Central and Southern) as well as the planned North Amethyst drill centre (representing a total study area of approx. 1,200 km²). Commercial fish were also sampled in the vicinity of the drill centres (Study Area) and at more distant Reference Areas (control-impact design). Tissue samples were analysed for chemical body burden and taste.</p>	
<p>Physical and Chemical Effects</p>	<p>Biological Effects</p>	<p>General Comments/Conclusions</p>
<ul style="list-style-type: none"> • Sediments were uniformly sandy (usually more than 90% sand) with low fines and gravel content. TOC content was also low, usually less than 0.1%. Drilling discharge effects on sediment grain size and TOC content were weak. • Over all stations, fines content decreased significantly with increasing distance from the nearest drill centre and increased with increasing depth. The depth effects were not significant for 2006, although they were reportedly significant and stronger than distance effects in past years. • TOC content increased with depth and decreased with increasing distance from the nearest drill centres. Depth effects were significant, but distance effects were not. • Two drilling mud tracers were used to assess the extent of drilling discharge impacts on bottom sediments: barium and >C10-C21 hydrocarbons (an indicator of SBMs). 	<ul style="list-style-type: none"> • In general, effects in laboratory toxicity tests were sporadic and unpredictable. None of the 252 sediment samples collected to date were toxic to bacteria. • In the amphipod tests, survival was always greater than 70% and usually greater than 80%. However, the number of stations with samples considered toxic to amphipods has increased over time: 0 in 2000 and 2004; 1 in 2005; 3 in 2006, 8 in 2008. Stations with low survival in the amphipod test were closer to drill centres (within 5 km) than most stations, but other stations near drill centres with elevated tracer levels had high amphipod survival. • In 2008 and in previous years, there were no detectable project effects on many benthic invertebrate community summary measurements, including richness, diversity and evenness. However, standing crop (extending to 1.5 km from source), total abundance, overall community composition, polychaete dominance, Paraonidae (Polychaeta) abundance (extending 	<ul style="list-style-type: none"> • There was clear evidence that concentrations of two drilling mud tracers (barium and >C10-C21 hydrocarbons) were elevated by drilling activity near drill centres. • Barium contamination extended to 2 km from source, and >C10-C21 hydrocarbon contamination extended to 10 km from source. • Evidence for other sediment effects was more equivocal (fines content, sulphur and sulphide concentrations) or lacking (TOC, metals other than barium). • Overall, barium concentrations from stations sampled in all sample years progressively increased over time. • Overall, concentrations of >C10-C21 hydrocarbons were a better indicator of drilling activity for White Rose than barium. • Distance gradients were steep in all years, with hydrocarbon concentrations decreasing by 100 to 1,000 fold over 10 km. • Although increases in amphipod toxicity may suggest project effects, any effects have largely been unpredictable in time and space.

Summary of Recent Mud and Cuttings Offshore Discharge EEM Studies

Physical and Chemical Effects	Biological Effects	General Comments/ Conclusions
<ul style="list-style-type: none"> • Barium concentrations decreased significantly with distances from the Southern and Central drill centres after drilling began at these two centres. However, there was no evidence of contamination from the Northern drill centre after drilling began at this centre. • The estimated zone of influence for barium was 2.4 km from the nearest drill centre in 2008. Weak directional effects were noted for both tracers in 2006, with dispersion primarily to the southeast within 1 km from the Southern and Central drill centres. This is consistent with current patterns. • In the 2004 samples, hydrocarbon concentrations decreased significantly with increasing distances from the Northern and Southern drill centres. For the Central drill centre, concentrations did not decrease with increasing distance in 2004, but did in 2005, 2006 and 2008. • Concentrations in 2005, 2006 and 2008 were greater than in 2004. The estimated zone of influence for >C10-C21 hydrocarbons in 2006 was 6 km from the nearest drill centre, and 10 km in 2008. • The White Rose program also included analysis of sediment samples for a suite of PAHs. All of the concentrations were below reportable detection limits. • In 2006 and past years, there was some evidence of decreases in sulphur concentrations with distance from the drill centres. In 2006, sulphide levels were elevated at a few (four) stations near drill centres (usually within 500 m). In 2004 and 2005, most sulphide concentrations were below reportable detection limits. In 2008, sulphur, and to some extent sulphide, concentrations were elevated within 0.5 km to 1 km of drill centres. • In 2005, redox levels increased with distance from drill centres and decreased with increasing tracer concentration. This was not noted in 2006. 	<p>4 km from source) and Amphipoda abundance were affected by project activity. The affected variables and the strength of effects varied among post-drilling years and among drill centres, and there have been few consistent response patterns. However, it is reasonable to conclude that at least some taxa were affected in every post-drilling year.</p> <ul style="list-style-type: none"> • Estimated zones of effects for polychaete dominance, overall community composition and Paraonidae abundance were approximately 1 km to 5 km. In 2005, effects on Amphipoda appeared to extend to even greater distances. However, these effects were considerably weaker in 2006, and Amphipoda were a relatively small component of the invertebrate community. In 2008, the spatial extent of effects on total abundance and abundance of amphipods and the polychaete Spionidae could not be estimated because relationships with distance from source were weak. • Overall, the zone of effects on benthic invertebrates (1 km to 5 km from source) extended beyond the 500-m zone of effects predicted in the White Rose EIS. The causal mechanism is not clear. Elevated barium concentrations are unlikely to be the direct cause of any observed effects because effects occurred within the background range of barium concentrations. • In terms of hydrocarbon toxicity, estimated thresholds for in situ effects on polychaetes and Amphipoda in 2005 and 2006 were generally towards the lower end of the 1 mg/kg to 10 mg/kg range, or approximately three orders of magnitude below the laboratory effects threshold. Given the differences between field measurements and laboratory measurements, reduced field abundances are probably not due to direct acute toxicity. The report suggests that community effects could be due to indirect effects, chronic toxicity involving longer term exposure, or some correlate of hydrocarbon concentrations. 	<ul style="list-style-type: none"> • The zone of effects on benthic invertebrates extended to 1 km to 5 km from source. • A safe conclusion based on all sample years is that effects on Paraonidae (Polychaeta) abundance extend to at least 1–2 km and possibly to 5 km. • From 2004 to 2008, total abundance was approx. 20%–40% lower at stations within 2 km from active drill centres. • However, there were no detectable project effects on many benthic invertebrate community summary measurements, including richness, diversity and evenness (and standing crop when all years data are considered). • The affected variables and the strength of effects varied among post-drilling years and among drill centres, and there have been few consistent response patterns. • In contrast to the documented sediment contamination and benthic invertebrate effects, no effects on commercial fish were identified. • The White Rose program also included analysis of metals and PAHs in tissue samples from snow crab and American plaice, with no tissue contamination noted for either species. • No other project-related tissue contamination was noted for snow crab or American plaice. Neither resource was tainted, and American plaice health was similar between White Rose and more distant Reference Areas. • Survival in toxicity tests was not significantly correlated with >C10-C21 hydrocarbon concentrations in any post-drilling year, and correlations with various distance measurements were weak and usually not significant.

Summary of Recent Mud and Cuttings Offshore Discharge EEM Studies

Physical and Chemical Effects	Biological Effects	General Comments/ Conclusions
<ul style="list-style-type: none"> • The White Rose monitoring program (Husky Energy, 2006–2007) included collection of sediment samples for a suite of metals (aluminum, antimony, arsenic, barium, beryllium, cadmium, chromium, cobalt, copper, iron, lead, lithium, manganese, mercury, molybdenum, nickel, selenium, strontium, thallium, tin, uranium, vanadium and zinc). Results showed that concentrations of metals other than barium were unaffected by drilling. 	<ul style="list-style-type: none"> • No conclusive results were noted for crab biological characteristics (size and moult frequency). Continuing through 2008, taste tests detected no difference between Reference and Study Area snow crab and American plaice (i.e., no indication of taint). No drilling-related effects on gross pathology, including external and internal abnormalities, or hematology were detected. • Metals concentrations in snow crab claws and American plaice livers and fillets from the Study Area were generally similar to or lower than Reference Area concentrations in 2004, 2005, 2006 and 2008. There were some significant differences among Reference Areas. Hydrocarbons were not detected in snow crab claws, and hydrocarbons detected in American plaice livers were attributed to naturally occurring fatty acids (e.g., glycerol) or sample contamination on board the sampling vessel. 	<ul style="list-style-type: none"> • The estimated spatial extent of effects was generally less extensive than the zone of chemical influence, and within the range seen in other comparable studies in the North Sea. • Concentrations of sediment metals other than barium were unaffected by drilling. • Based on the results to date, it is recommended that the next EEM sampling program take place in 2010.

Summary of Recent Mud and Cuttings Offshore Discharge EEM Studies

<p>Study: US Minerals Management Service (MMS) Study of the Effects of Oil and Gas Exploration and Development at Selected Continental Slope Sites in the Gulf of Mexico (CSA, 2006)</p>	<p>Description: A monitoring study was conducted between November 2000 and August 2002 to assess benthic impacts of drilling at four sites on the Gulf of Mexico continental slope. The MMS Monitoring Study (Continental Shelf Associates, Inc., 2006) included collection of box core samples for analysis of metals and hydrocarbons in the top 2 cm of sediments. The analysis included data for 13 metals in sediments: aluminum, arsenic, barium, cadmium, chromium, copper, iron, lead, mercury, manganese, nickel, vanadium and zinc. Baited traps were used to collect benthic macrofauna for analysis of 11 metals (all of the above except aluminum and manganese). Sediment and tissue samples were also analysed for the presence of PAHs. Study sites ranged in water depth from 1,034 m to 1,125 m and represented a range of drilling activities. Each of the four study locations consisted of a single near-field site and six far-field ("reference") sites. The near-field sites were centred on well locations, and the far-field sites were 10 km to 25 km away in the same water depths. Although previous wellsites were avoided to the extent practicable, most far-field sites had at least one previous well drilled within 10 km. Both water-based muds (WBMs) and SBMs were used at varying amounts during drilling at all four sites. SBMs used during this study included internal olefins such as Novaplus, Novadril or Syn-Teq; Petrofree LE, a linear-alpha-olefin; and Petrofree ester. The interval between cessation of drilling and the date when the surveys began ranged from 5 months to about 2 years.</p>	
Physical and Chemical Effects	Biological Effects	General Comments/Conclusions
<ul style="list-style-type: none"> • Near field concentrations of arsenic, cadmium, chromium, copper, lead, mercury and zinc were elevated in some near field sediment samples, as compared with far field samples. Generally, elevated concentrations of these metals were associated with high barium concentrations (i.e., drilling mud). However, these elevated concentrations are within the expected range of background concentrations for uncontaminated marine sediments. • Relatively low concentrations of aluminum, iron, nickel and vanadium were measured in some near field samples and were attributed to dilution of ambient sediments with barite, which contains no significant amounts of these metals. Also, concentrations of manganese were lower and more variable at near field sites, a result attributed to reductive dissolution of this metal at stations where the presence of drilling discharges created reducing conditions. • Calculations in the report indicate that the mercury concentrations in barite deposited at the study sites were in line with USEPA regulations, which allow a maximum level of 1 mg/kg in stock barite. 	<ul style="list-style-type: none"> • Near-field sites had patchy zones of disturbed benthic communities, including microbial mats, areas lacking visible benthic macroinfauna, zones dominated by pioneering stage assemblages, and areas where surface-dwelling species were selectively lost. • Macroinfaunal and meiofaunal densities generally were higher near drilling, although some faunal groups were less abundant in the near-field (amphipods, ostracods). • Amphipod densities in the near-field were negatively correlated with drilling mud indicators. Generally, near-field stations with high concentrations of drilling mud indicators had low amphipod densities. • Separately, acute toxicity tests showed that mean amphipod survival was significantly lower in sediments from near-field stations than in sediments from far-field stations. Amphipod survival in the toxicity tests was negatively correlated with drilling mud indicators. • Detailed taxonomic analysis of a subset of the macroinfaunal samples showed some stations near drilling had lower diversity, lower evenness and lower richness indices, compared with stations away from drilling. Species composition varied in relation to both geographic location and drilling impacts. 	<ul style="list-style-type: none"> • Physical, chemical and biological impacts of drilling activities were detected at all four sites. Cuttings and drilling mud accumulations were evident mainly within the 500-m radius near-field zone at all four sites, though there was geophysical and chemical evidence for deposits extending beyond this area. • Impacts noted within the near-field zone included elevated barium and TOC concentrations, low sediment oxygen levels, presence of microbial mats, and altered densities of meiofauna, macroinfauna, and megafauna. Within the near-field zone, impacts were patchy, with some stations showing conditions similar to those at the far-field sites. • At all four near-field sites, impacts were patchy, with some stations showing conditions similar to those at the far-field sites. Impacts generally were less extensive and less severe at post-exploration sites than at post-development sites. • Impacts attributable to SBM cuttings, such as elevated TOC, poor redox conditions and associated biological changes, were least severe at the site where the smallest quantities of SBM cuttings were discharged. However, the time elapsed since drilling also was longer at this site (about 2 years) than at the other three sites (5 to 14 months), and the less severe impacts may reflect recovery of this site over time.

Summary of Recent Mud and Cuttings Offshore Discharge EEM Studies

Physical and Chemical Effects	Biological Effects	General Comments/ Conclusions
<ul style="list-style-type: none"> • With two exceptions, sediment PAH concentrations in the top 2 cm of sediments were relatively low, ranging from 43 ng/g to 748 ng/g dry wt. However, two samples at one development site (Garden Banks Block 516) had much higher concentrations (3,470 ng/g and 23,840 ng/g). Both of these stations were within 300 m from the wellsites. The report suggests the PAHs came from some other drilling or production activity rather than drilling discharges. • Geophysical and chemical measurements indicated that a layer of SBMs and cuttings was deposited mainly within the 500-m near-field radius. Geophysically mapped mud and cuttings zones ranged from 13 ha to 109 ha in area, with larger zones observed at post-development sites. • These zones typically extended several hundred metres from wellsites, with the greatest extent (about 1 km) observed at two post development sites. Cuttings deposits were estimated to be up to 45 cm thick at one site. • Areas of SBM cuttings deposition were associated with elevated total organic carbon (TOC) and anoxic conditions, including low dissolved oxygen, negative Eh, and shallow depth of the oxidized layer. • Sites with larger volumes of SBM cuttings discharges had the greatest reduction in mean sediment oxygen levels. 	<ul style="list-style-type: none"> • Station/cruise groups most likely affected by drilling were dominated by high abundances of one or a few deposit-feeding species, including known pollution indicators. • Annelid (predominantly polychaete) and gastropod densities in the near-field were positively correlated with drilling mud tracers. Some near-field stations had elevated polychaete densities. A few near-field stations had very high gastropod densities. • Meiofaunal densities in the near-field were not consistently correlated with drilling mud tracers or other sediment variables (TOC, grain size fractions). • Among megafauna, increased fish densities and reduced ophiuroid densities were noted in the near field of two sites. • Concentrations of 11 metals (arsenic, barium, cadmium, chromium, copper, iron, lead, mercury, nickel, vanadium and zinc) were determined in samples of giant isopod <i>Bathynomus giganteus</i> and red crab <i>Chaceon quinquegens</i> from near field and far field stations at two development sites. • The most consistent finding in the metals data was elevated barium in isopods from one site and in crabs from both sites. The only other metal with more than one significant result was chromium (elevated in isopods from one site and crabs from the other). In the case of all other metals: there were either contradictory findings between sites (cadmium and vanadium in crabs); metals were significant in only one organism at one site (lead in isopods); metals were higher at far field sites (arsenic, copper, nickel and zinc in crabs; cadmium and mercury in both isopods and crabs); or there were no significant differences (iron). • Industrial barite (and its trace components) used in drilling muds typically has low bioavailability to marine organisms. The elevated barium concentrations detected in isopods and crabs may reflect small amounts of sediment particles retained in the gut. 	<ul style="list-style-type: none"> • The severity of discharge-related impacts varied, depending on the volume of SBM cuttings discharged and the time elapsed since drilling was completed. • Concentrations of drilling mud tracers were elevated by several orders of magnitude within near-field sites and were positively correlated with estimated discharge volumes of SBM cuttings. • Observations from the study sites and adjacent lease blocks suggest that geophysically detectable mud/cuttings deposits may persist for 5 years or more.

Summary of Recent Mud and Cuttings Offshore Discharge EEM Studies

<p>Study: Risks Associated with Drilling Fluids at Petroleum Development Sites in the Offshore: Evaluation for the Potential of an Aliphatic Hydrocarbon Based Drilling Fluid to Produce Sedimentary Toxicity and for Barite to Be Acutely Toxic to Plankton (Payne et al., DFO, 2006)</p>	<p>Description: A series of five lab experiments was conducted to assess sediment toxicity associated with IPAR (an aliphatic hydrocarbon alkane based drilling fluid used frequently in offshore NFDL). Two pilot studies were also carried out to assess the potential for barite and bentonite to produce false positives in the Microtox Assay, as well as the acute toxicity potential of barite.</p>	
Physical and Chemical Effects	Biological Effects	General Comments/ Conclusions
<ul style="list-style-type: none"> • Sediment toxicity confined to within tens of metres from cuttings piles associated with IPAR. • IPAR can be expected to effectively degrade in sandy/silty sediments but likely not at a rate that would cause substantial anaerobiosis and sediment toxicity. • Ester based fluids have the potential to cause higher levels of sediment toxicity than alkane based fluids. 	<ul style="list-style-type: none"> • Relatively high concentrations of barite added to water were not toxic to capelin or snow crab larvae or planktonic jellyfish after 24 hours of continuous exposure. • No mortalities were observed for flounder that were force fed high concentrations of barite weekly for one month. • Any major change in sediment communities should be quite confined around rig sites. • Also noted from several coastal study sites is the common occurrence of negative redox in natural sediments. • Ester fluids will degrade faster, possibly resulting in increased habitat alteration, but in the near vicinity of the rigs. • Many naturally fine grained sediments can be expected to be falsely toxic in the Microtox assay. 	<ul style="list-style-type: none"> • Based on monitoring of the seabed around Hibernia and Terra Nova after extensive drilling, any significant toxicity resulting from the use of IPAR should be confined to within tens of metres from cuttings piles. • This finding is also based on toxicity tests of IPAR with Microtox, amphipods and polychaetes, and studies of IPAR anaerobiosis and weathering. • Microtox analysis can produce false positives in relation to grain size.

Summary of Recent Mud and Cuttings Offshore Discharge EEM Studies

<p>Study: Environmental Effects of Exploratory Drilling Offshore Canada: Environmental Effects Monitoring Data and Literature Review – Final Report (Hurley and Ellis, 2004)</p>	<p>Description: The objective of this study was to determine—based on a scientific examination of pertinent environmental effects monitoring (EEM) information and data associated with offshore exploratory and development drilling in Canada, and in consideration of applicable international scientific information—what impacts of exploratory drilling are known, what impacts are uncertain, and what scientific gaps exist in the scientific understanding either of the interaction between exploratory drilling and the receiving environment or the changes or impact in the receiving environment as a result of the activity, including cumulative impacts. Methods focused on a review of the scientific literature to provide a synthesis of the broader scientific knowledge of the interactions between exploratory drilling and the receiving environment, and on a review of pertinent Canadian EEM data to evaluate the interactions between exploratory drilling and the receiving environment. A total of nine EEM programs were reviewed.</p>	
<p>Physical and Chemical Effects</p>	<p>Biological Effects</p>	<p>General Comments/Conclusions</p>
<ul style="list-style-type: none"> • Cuttings piles may smother benthic organisms within 100 m of a drill site. • Average background levels for drilling waste (barium & TPH) reported from the literature review are reached statistically at 3,000 m, with single transect values elevated out to 8,000 m. • Canadian EEM data for exploration wells detected drill waste signals to 250 m. For multi-well development programs, drill waste signals were detected as far as 3,000 m (Ba) and 8,000 m (TPH) in sediments typically along the major current axis. • Water based drilling fluid solids can be transported over long distances (35–65 km) based on a study of eight exploration wells (Neff et al., 1989). • Taint was not detected for any of the species tested within the Canadian EEM programs, except for blue mussels at COPAN. • Limited data on taint effects reported in the primary scientific literature. Terra Nova did not detect taint in scallop tissues; however, hydrocarbon concentrations were found to accumulate in the viscera rather than in the edible ‘meats’ (adductor muscles). 	<ul style="list-style-type: none"> • Changes in the diversity and abundance of benthic organisms were generally detected within 1,000 m for single wells from both the EEM data and literature review. In one case, changes in benthic diversity and abundance were recorded out to 2,000 m from a single exploration well (CSA, 1989). • Elevated concentrations of barium in tissues of polychaetes, brittlestars and bivalves were detected as far as 1,600 m from a single well discharging WBM (Mariani et al., 1980). • The Canadian EEM data documented body burden concentrations of TPH in sea scallops as far as 2,600 m for the multi-well Terra Nova program. • TPH was also detected in blue mussels (COPAN and SOEP NT#1), with TPH detected out to 1,000 m from a single well (SOEP NT#1). • Studies on organic condition indices and energy reserves indicate little potential for toxicity beyond 1–2 km from rig sites (Cranford et al., 2001). • For the Canadian EEM data no fish health effects were observed for any of the tested species across all reviewed sites. • Interpretation of these indices requires consideration of the mobility of fish species, the relevant scales of environmental change and exposure to other stressors. For highly mobile species, the degree of exposure is unknown. There are few dose-response experimental studies linking body burdens of chemicals to effects. 	<ul style="list-style-type: none"> • In general, the zone of detection for SBM in sediments was found to be smaller than for WBM. However, the biodegradation properties of SBM differ, with high oxygen demand and potential longer degradation time scales. Existing field data suggest these materials will be substantially degraded on a time scale of one to a few years. • Because of high levels of natural, sampling and analytical variability and the high costs inherent to marine field studies, the statistical power to detect impacts was limited (EPA, 2000). However, the spatial areas affected by drilling discharges documented in both the Canadian EEM data and the scientific literature were consistent. • Measuring the effects of elevated concentrations of contaminants at the population, community or ecosystem levels remains challenging. However, the present data base would seem to provide a reasonable appreciation of the scope of benthic impacts. • There is considerable consistency in the monitoring results for the Gulf of Mexico, North Sea and Canadian East Coast programs despite differences associated with the volumes and types of drilling waste discharged, the scale and location of drilling, and variations in sampling programs.

Summary of Recent Mud and Cuttings Offshore Discharge EEM Studies

<p>Study: Gulf of Mexico Comprehensive Synthetic Based Muds Monitoring Program (CSA, 2004)</p>	<p>Description: As part of the National Pollutant Discharge Elimination System (NPDES) general permit issued by U.S. Environmental Protection Agency (USEPA) Region 6 in 2001, operators in the Gulf of Mexico participated in a joint industry seabed study. The joint study, entitled "Gulf of Mexico Comprehensive Synthetic Based Muds Monitoring Program," was sponsored by the SBM Research Group, composed of offshore operators, mud companies, the MMS and the Department of Energy. The study was conducted by Continental Shelf Associates, Inc. (2004). A scouting cruise was performed in June 2000 to evaluate the suitability of 10 candidate sites. A screening cruise was conducted in August 2000, and geophysical data were collected at eight sites to evaluate the potential presence of substantial cuttings piles. Five of these sites were visited previously during the scouting cruise; the remaining three sites were located on the continental slope. Sediment samples were collected at each site and analysed for a small number of physical, chemical and biological parameters to document the presence and distribution of SBM cuttings accumulations on the bottom and evaluate the general characteristics of the benthic communities. Eight sites were surveyed during sampling cruises in May 2001 and May 2002. Four sites were located on the continental shelf in water depths from 37 m to 119 m, and four were located on the continental slope in water depths from 338 m to 556 m. Sediment sampling was performed in three zones around each discharge site: near-field (0 m to 100 m from the discharge site), mid-field (100 m to 250 m from the discharge site), and far-field reference (3,000 m to 6,000 m from the discharge site). Surficial sediments were collected at each station for analysis of physical, chemical and biological parameters. Benthic macrofauna were counted and identified, and laboratory sediment toxicity tests were conducted on sediments collected at selected sites. A summary is also presented by Neff et al. (2005).</p>	
Physical and Chemical Effects	Biological Effects	General Comments/Conclusions
<ul style="list-style-type: none"> • Evidence of drilling discharges was detected at all eight sites. WBMs and cuttings and SBM cuttings were discharged at each site, and it was not possible to determine whether or not the cuttings detected in the sediments were SBM cuttings. Physical evidence of cuttings in sediments depended primarily on the time elapsed since the last cuttings discharge at a site. Cuttings were visible in all near-field zones. • Elevated concentrations of barium (a tracer of drilling mud), SBM and TPH were detected in sediments from the near-field and mid-field zones at the sites; however, the distributions of the materials were patchy. Concentrations at far-field stations generally represented background levels. 	<ul style="list-style-type: none"> • Sediment toxicity, as determined in the laboratory from a sediment bioassay with the amphipod <i>Leptocheirus plumulosus</i>, was restricted to a few locations near the drilling discharges; most of the sediments in the near-field and mid-field (<250 m) were not toxic. Amphipod survival exceeded 75% in all far-field samples at continental shelf and continental slope sites, and therefore these sediment samples were not considered toxic. Of the samples collected within 250 m of the continental shelf and continental slope discharge locations, 73% and 56%, respectively, had amphipod survival exceeding 75% and were considered not toxic. Changes in sediment chemical composition or physical properties due to cuttings deposition were probably responsible for most of the toxicity. 	<ul style="list-style-type: none"> • Most cuttings appeared to be deposited within 100 m to 250 m of the discharge site. • Large accumulations of cuttings, such as those reported in the North Sea, were not observed near the eight multi-well discharge sites monitored. However, there was evidence of cuttings deposition and physical, chemical, toxicological and ecological alteration of the benthic environment in all near-field (≤ 100 m) and some mid-field (100 to 250 m) zones around discharge sites. The distribution of cuttings in sediments was extremely patchy, but tended to decrease sharply with distance from the discharge sites.

Summary of Recent Mud and Cuttings Offshore Discharge EEM Studies

Physical and Chemical Effects	Biological Effects	General Comments/ Conclusions
<ul style="list-style-type: none"> • Concentrations of barium were above background levels in >95% of the sediments collected from near field stations (<100 m from site centre), with levels as high as 35% barium relative to background barium concentrations of 0.1% to 0.3%. Elevated barium levels extended well into the mid-field zone (100 m to 250 m from site centre) at slope sites where horizontal dispersion was extended because of greater water depths (500 m versus about 100 m on the shelf). Concentrations of cadmium, lead, mercury and zinc were elevated by factors of 2 to 5 above background levels (far field) in sediments from more than 20 of the 58 sediment samples analysed. • There was a sharp decrease in concentrations of cuttings and chemicals in sediments with distance from the discharge sites, which indicates that drill cuttings solids, especially from SBM cuttings, are deposited close to the discharge site. Most cuttings appeared to be deposited within 100 m to 250 m of the discharge site at both continental shelf and continental slope water depths. • A combination of visual, geophysical, and chemical/physical measurements indicated that SBM cuttings do not accumulate in large piles, as has been observed in the North Sea for discharges of oil-based drilling muds and cuttings. • Measurements of oxygen, TOC, reduction/oxidation potential and manganese in sediments, and signs of possible SBM cuttings-related organic enrichment indicated such enrichment near the discharge locations. • Concentrations of nine metals (arsenic, cadmium, chromium, copper, lead, mercury, nickel, vanadium and zinc) were determined in 42 surface sediments (0 cm to 2 cm) and 16 subsurface sediments (from eight cores) collected during the screening cruise (July 2000). The trace metal data complement results for aluminum, barium, iron and manganese for the same samples. 	<ul style="list-style-type: none"> • There were substantial differences in the benthic communities at the three sites examined. However, the communities of organisms observed at different zones within a given site were generally similar. At two of the three sites examined, the abundance of organisms in different zones was similar. At the site with the highest SBM concentrations of the three biological study sites, the abundance and diversity of the benthic community were reduced within 250 m of the site centre. • There was evidence of recovery in the time between the two sampling cruises at this site. Near- and mid-field sediments at the other two sites (with lower SBF concentrations) had only moderately disturbed benthic community structure, compared to the corresponding far-field samples. Variability of all benthic community parameters such as diversity and evenness was greatest in the near-field zone and generally much lower in the far-field zone. In the near-field zone, this variability was probably due to variations in sediment textures and patchy distributions of cuttings. • For the three sites where sediment chemistry, benthic faunal community structure and sediment toxicity were measured, a sediment quality triad analysis was performed to develop an integrated assessment of drillsite sediment conditions. This analysis clearly showed reduced sediment quality in the near-field compared to the mid-field. However, the triad analysis showed clear evidence of recovery over the 1-year period between the sampling cruises. 	<ul style="list-style-type: none"> • At two of the three sites analysed, minimal changes in ecological parameters used in the triad analysis suggested that the habitat quality of the sediments had not been seriously degraded by a long history of discharges at those sites. • Changes to benthic communities were not severe, even at the sites that were the most heavily contaminated with drill cuttings, and probably were caused primarily by organic enrichment of sediments by deposition of biodegradable SBM cuttings. Where impacts were observed, progress towards physical, chemical and biological recovery appeared to occur during the 1-year period between the two sampling cruises. • There was evidence of recovery or decrease over time in the severity of disturbance in the sediments near the discharge locations during the year between the two sampling cruises. • Concentrations of monitored components of SBM cuttings in sediments tended to decrease or return to background values with time after the last cuttings discharge. Possible mechanisms included microbial biodegradation (breaking down of materials by micro organisms) and burial by natural sediment deposition or bioturbation (reworking of sediments by marine organisms). • Concentrations of total petroleum hydrocarbons (TPH) and SBF were measured in sediments from the vicinity of eight sites. Generally, SBF residues were found at the highest concentrations and greatest frequency in near-field sediment zones. Less frequent findings and lower concentrations of SBF were found in mid-field zone sediments. Only sporadic, low-level detections (<5 mg/kg) of SBF residues were found in the continental shelf or continental slope far field surface sediment stations. At near field sites where substantial concentrations of SBF were observed during Sampling Cruise 1, concentrations were up to an order of magnitude lower one year later.

Summary of Recent Mud and Cuttings Offshore Discharge EEM Studies

<p>Study: MAPEM Project Environmental Monitoring of Offshore Drilling for Petroleum Exploration Offshore Brazil (MAPEM, 2004)</p>	<p>Description: The MAPEM Project (Project Environmental Monitoring of Offshore Drilling for Petroleum Exploration) was conducted between 2001 and 2003 in Campos Basin offshore Brazil. The Eagle Well was located in a water depth of 900 m and was drilled mainly with a linear paraffin SBM composed primarily of C14 to C19 alkenes. The project was conducted by researchers from the Universidade Federal do Rio Grande do Sul and Universidade Federal de Santa Catarina. Three deepwater oceanographic cruises were conducted in April and July 2001 and June 2002, respectively. The Eagle Well was drilled in June 2001. A circular 2,500 m-radius area of the seabed was studied in detail, with the use of a box corer for sampling bottom sediment for biological, chemical and geological analysis, followed by side-scan sonar bottom imaging and water column profiling, as well as photographs and videos. The sampling plan, based on discharge modeling, included 54 stations, distributed in the form of a concentric radial sampling grid. Six samples were collected at circles located at 50 m and 100 m from the wellsite, and 12 others at 150 m, 300 m and 500 m. Additionally, six reference samples were collected at 2,500 m from the wellsite to provide a measure of changes in the region due to natural variability, independent of the drilling activity. The statistical sampling design—BACI (Before After Control Impact) —was intended to provide a basis for separating out effects of drilling discharge from those that vary naturally over space and time. The number of samples collected in this study allowed for an additional analysis to look more closely for impacts in areas known to have indicators of drilling discharges.</p>	
<p>Physical and Chemical Effects</p>	<p>Biological Effects</p>	<p>General Comments/Conclusions</p>
<ul style="list-style-type: none"> • Sediment samples from both post drilling cruises showed an elevated level of the C14 to C19 hydrocarbons indicative of the SBM base fluid. The concentrations, however, are low when compared to the concentrations in the discharged cuttings and low when compared to other studies performed in shallow water. Although the discharged cuttings contained hydrocarbon concentrations in the 6% up to 10% range, the seabed sediments contained a maximum of 23.3 ppm. This is likely partly the result of dilution with natural sediments, indicating significant dispersion of the SBM cuttings on the seabed. • Total hydrocarbon concentrations in seabed sediments were very low (all below 30 ppm) and substantially lower than those that have been shown to cause effects on macrobenthos in previous studies (~1,000 ppm). There were no increases in polynuclear aromatic hydrocarbons (PAHs), which are not normally found in SBMs. • Post-drilling sediments did not contain elevated metals levels, except for barium. Barium was elevated out to about 150 m from the wellsite, presumably because of seafloor discharges during riserless drilling. 	<ul style="list-style-type: none"> • Both meiofauna and macrofauna showed significant decreases in species richness (families and genera) and density, and changes in trophic structure (significant increase of non selective deposit feeder nematodes and discretely motile deposit feeders in the macrofauna) on the cruise conducted one month after drilling. Statistical analysis showed that changes in several macrofaunal descriptors were related to drilling activities. The analysis also showed that changes were less evident in meiofauna. Changes in meiofaunal structure occurred mainly in the northern portion of the study area, limited to a 500-m radius from the wellsite. • The first post-drilling survey showed that drilling activities produced measurable localized effects on macrofaunal community structure. One year after drilling, a recolonization process was observed, with the probable recovery of the community in most of the study area. Three stations had evidence that the community continued in the recovery process one year post-drilling. 	<ul style="list-style-type: none"> • Based on a combination of physical, chemical and biological measurements, the seabed area with detectable disturbance was limited to a 500-m radius impact zone envisioned during the initial study design. Benthic community effects appeared to be mainly due to physical effects from drilling discharge. The organic materials associated with the SBM base fluid did not appear to add substantially to impacts on the benthic components analysed. • Most of the sampling stations with evidence of impacts on the macrofauna one month after drilling had shown a probable recovery of the area as a result of the progressive recolonization by the fauna one year post-drilling. Three sampling stations still showed signs of macrofaunal disturbance one year post-drilling, and the community continued in the recovery process. These stations had a predominance of opportunistic organisms, tube builders that use the resources available at the sediment-water interface, characteristic of the first stages of colonization in the succession process in disturbed environments.

Summary of Recent Mud and Cuttings Offshore Discharge EEM Studies

Physical and Chemical Effects	Biological Effects	General Comments/ Conclusions
<ul style="list-style-type: none"> • Effects on benthos were found to be poorly correlated with sediment chemistry measures (hydrocarbons and metals). 	<ul style="list-style-type: none"> • Both benthic faunal components showed poor correlations to the chemical parameters analysed. This suggests that the disturbance caused by the discharge of cuttings on the benthos was primarily due to physical effects. For meiofauna, this is underscored by the absence of high hydrocarbon concentrations at stations in which the faunal structure has been altered (up to a 500-m radius). Likewise, meiofauna has not been affected at stations where relatively high hydrocarbon scores have been recorded. The fact that no significant chemical effect was detected is not unexpected because of the low hydrocarbon concentrations observed. 	<ul style="list-style-type: none"> • For the meiofauna, although most of the univariate measures did not show effects, multivariate statistical methods were able to clearly identify changes in the community structure related to drilling. One year after drilling, meiofaunal density and richness exhibited values similar to those at the pre-drilling period. However, change in meiofaunal structure was still detected, with an increase of copepod densities and epigrowth-feeder nematodes. • In general, study results suggest that the primary cause of benthic effects was physical (i.e., burial) rather than chemical (toxicity).

Summary of Recent Mud and Cuttings Offshore Discharge EEM Studies

Study:	Description:	
Impact Assessment and Benthic Recruitment Following Exploration Drilling in the South Caspian Sea (Tait et al., SPE, 2004)	Pre- and post-drilling environmental studies were conducted around a 6,737 m deep exploration well drilled in a water depth of 145 m using both WBM (upper sections) and SBM (lower sections where stability was essential). Using a radial sampling pattern, sediment chemistry was measured as well as total infaunal abundance, species richness, biomass and distribution of major taxa (5 sampling surveys were conducted between 1998 and 2002). The data were interpreted for 4 physical, 14 chemical and 27 biological key variables. ANOVA and Duncan's statistical comparisons were made with distance from the well sites taken into consideration.	
Physical and Chemical Effects	Biological Effects	General Comments/Conclusions
<ul style="list-style-type: none"> • Cross-sectional photographic images of the seafloor showed significant oxygen demand within 5 m of the wellsite. • Settled cuttings were largely confined at the well centre, barely visible at 200 m and not discernable at 400 m (8 months after drilling) • Physical sediment changes attributed to overlying cuttings and adhered muds were mostly contained within 50 m of the well site, but were also elevated at 200 m, compared to reference stations. • Concentrations of barium and HCs decreased significantly with distance from the well, with a directional component likely reflecting hydrodynamic conditions. • PAHs were contained less than 200 m from the well, while other HCs reached background levels between 400 m and 600 m. 	<ul style="list-style-type: none"> • Significant differences were observed in the macrofauna between pre- and post-drilling. • Total abundance was depressed at the well site with less than half those recorded from the 200 m to 400 m post-drilling station groups. • The post-drilling pattern provides strong evidence of a localized effect, particularly in the absence of a significant response gradient within the 200 m to 800 m range. • Amphipoda, Cumacea and Gastropoda were absent within 50 m of post-drilling, but had enhanced abundances, likely in response to moderate organic enrichment at 200 m and 400 m distances, where there was no evidence of excessive oxygen demand. • Ostracod crustaceans were rare in pre-drilling samples but were the most abundant post drilling group within 400 m of the well, indicating that elevated organics may be a macrofaunal enhancer. • For most groups, conditions at the well site are still inimical to recruitment, presumably from excessive sediment oxygen demand. This inhibitory effect extends out to 200 m for the sensitive amphipod group, whereas ostracods have actively recolonized the well site. 	<ul style="list-style-type: none"> • Observable changes in sediment physical, chemical and biological characteristics were largely confined to a radial distance of approx. 400 m centred on the well site. • Effects from mud and cuttings discharge reflect a combination of possible factors including burial/smothering, avoidance or attraction to the area by motile species such as crustaceans, alteration of larval settlement affecting recruitment, and differences in post-settlement survival. • Strong inferential evidence exists for impacts to various benthic groups, with reductions in species density and abundance near the well site (50 m). Typically, these differences approach reference conditions between 200 m and 400 m of the well. • Data indicate that recolonization of the well site area is under way eight months after drilling. • The presence of all major taxa at distances of 200 m and beyond indicates a recruitment approaching normal. • As sediments trend toward regional background levels with distance from the well, the near field depression and intermediate enhancement effects will subside as cues for recruitment become more homogenous within the study area. This time frame will primarily be a function of hydrodynamic processes and biodegradation of SBM base fluid.

Summary of Recent Mud and Cuttings Offshore Discharge EEM Studies

<p>Study: Environmental Aspects of the Use and Disposal of Non-Aqueous Drilling Fluids Associated with Offshore Oil & Gas Operations (OGP, 2003) Also summarized in Melton et al., SPE 2004</p>	<p>Description: The purpose of this paper was to summarize the technical knowledge of discharges of cuttings when non-aqueous drilling fluids (NADFs) are used, with a focus on SBM. The document summarizes the current body of knowledge of the environmental aspects of the disposal of NADF cuttings by discharge into the marine environment. The report evaluated the results from over 75 publications and compiled the findings from all available research on the subject at that time. It was intended to provide technical insight into this issue as regulations are considered in countries around the world.</p>	
<p>Physical and Chemical Effects</p>	<p>Biological Effects</p>	<p>General Comments/Conclusions</p>
<ul style="list-style-type: none"> • It is generally thought that the largest potential impact from discharge will occur in the sediment dwelling (benthic) community. The risk of water-column impact is low because of the short residence time of cuttings as they settle to the sea floor and the low water solubility and aromatic content of the base fluid. • Initial environmental impacts on benthic organisms from the discharge of NADF cuttings are caused by physical burial. • Initial deposition thickness depends on a number of factors including the amount of material discharged, water depth, discharge depth, the strength of currents in the area and the rate at which cuttings fall through the water column. • Neff et al, 2000, summarize the results of seabed monitoring around 21 single well sites where SBM cuttings were discharged in the UK sector of the North Sea. • There is no clear relationship between concentrations of SBM in sediments, and water depth, mass of cuttings discharged or mass of fluids adhering to cuttings that are discharged. The amount of cuttings accumulating in sediments is dependent on a complex interaction of discharge rate and mass, water depth, current structure, and the type of fluid and cuttings. In most cases, SBM cuttings do not penetrate or mix deeply into surface sediments near the platform. 	<ul style="list-style-type: none"> • In sediments with substantially elevated NADF concentrations, impacts include reduced abundance and diversity of fauna. Recovery tends to follow a successional recolonization, starting with hydrocarbon-tolerant species and/or opportunistic species that feed on bacteria that metabolize hydrocarbons. As hydrocarbon loads diminish, other species recolonize the area to more closely resemble the original state. • NADFs are not expected to bioaccumulate significantly because of their extremely low water solubility and consequent low bioavailability. Their propensity to biodegrade further reduces the likelihood that exposures will be long enough for a significant bioaccumulative hazard to result. • Major overall conclusions of a survey of field studies by Jensen et al. (1999) were as follows: • Results from monitoring studies on fields where only SBMs and WBM's have been used to indicate that discharges of cuttings associated with these fluids have little or no effect on benthic fauna outside a radius of 250 metres. The exception to this is where large volumes of drilling cuttings have been discharged. • In general, largest variations in biological diversity have been found beyond 250 metres, regardless of what the sediment chemistry is, and it is difficult to isolate discharge effects from natural variation. Increase in the density of individuals of tolerant indicator species can be found up to 1,000 metres from some installations. 	<ul style="list-style-type: none"> • A compilation of field monitoring results at offshore drilling sites reveals a relatively consistent picture of the fate and effects of drill cuttings associated with NADFs. The degree of impact is a function of local environmental conditions (water depth, currents, temperature), and the amount and type of waste discharged. • Cuttings discharged with newer fluids resulted in a smaller zone of impact on the sea floor, and the biological community recovered more rapidly. • The development of more environmentally friendly fluids has been undertaken to reduce the environmental impact associated with the discharge of drill cuttings when SBMs are used, and make that option more broadly acceptable. When applicable, offshore discharge is the safest and most economical option. • Field studies indicate that areas that recover most rapidly are those with high-energy seabed conditions. • SBM cuttings discharges have had far fewer effects on soft-bottom communities than OBM cuttings discharges, as effects on soft bottom communities from SBM cuttings discharges are rarely seen outside of 250–500 metres. • Impacts may arise from oxygen depletion and there may be a balance between short-term and long-term impacts. • It is probable that within three to five years of cessation of SBM cuttings discharges, concentrations of synthetic in sediments will have fallen to sufficiently low levels and oxygen concentrations will have increased sufficiently throughout the previously affected area that complete recovery will be possible (Neff et al, 2000). • Recent advances have allowed production of a variety of NADFs with very low concentrations of toxic components.

Summary of Recent Mud and Cuttings Offshore Discharge EEM Studies

<p>Study: Assessment of Environmental Impacts from Drilling Muds and Cuttings Disposal Offshore Brunei (Sayle et al., 2002)</p>	<p>Description: In 2000 and 2001, an offshore survey and environmental assessment were conducted in association with drilling activities offshore Brunei (Sayle et al., 2002). The study was conducted by Adinin Jacques Whitford. A primary focus was to evaluate the environmental effects of disposal of OBM, ester-based synthetic mud (ESBM) and WBM in the marine environment of the South China Sea. Several wellsites were surveyed, encompassing varying water depths (20 m to 500 m) and time elapsed since drilling (less than 1 year to more than 13 years). Wellsites included two drilled with OBM, two drilled with ESBM, one drilled with WBM, and two older production sites with multiple wells. Key parameters (e.g., hydrocarbons, esters, metals, and redox potential) were examined at all sites. Side-scan sonar, detailed hydrographic imaging, seabed video, current information and benthic sampling results were also interpreted. A modified radial sampling pattern was used, oriented primarily with the predominant current direction.</p>	
Physical and Chemical Effects	Biological Effects	General Comments/ Conclusions
<ul style="list-style-type: none"> • Elevated TPH, lead, zinc and arsenic (from OBM disposal) have adversely affected the health of benthic communities. • Fine-grained sediments (i.e., silt and clay) appear to contribute to persistence of hydrocarbons in sediments. • The main effect of ESBM disposal was rapid depletion of oxygen in sediments due to bacterial degradation of the esters; however, this effect is limited to where mud and cuttings are concentrated. • The cohesiveness of ESBM on cuttings limits the spatial extent of the cuttings pile. • WBM indicators tend to disperse more widely than ESBM (up to 4,000 m vs 200 m); however, the benthos tends to recover more quickly from WBM disposal. 	<ul style="list-style-type: none"> • The OBM sites had the most severe and long lasting effects, including persistent elevated hydrocarbon concentrations, elevated metal concentrations (e.g., zinc), anoxic conditions, and deleterious effects on the benthic biota (reduced abundance and diversity). • The ESBM sites were located in different water depths (38 m and 486 m), but had similar effects. The ESBM cuttings piles were mainly localized within 150 m to 200 m of the wellsite. There were elevated levels of hydrocarbons and some metals and reduction in benthic abundance and diversity near the wellsite, as well as anoxic conditions and bacterial mats. • Effects on benthic macrofaunal diversity were evident out to distances of 1,600 m to 2,000 m from the wellsite. This zone of influence was attributed to the relatively large volume of cuttings at this multi-well site, as well as the potential of formation hydrocarbons on cuttings that were more widely distributed during the WBM drilling phases at this location. • The WBM site, located in a water depth of 46 m, had the least severe effects, with only slight reductions in benthic abundance and diversity evident approximately 2.5 years after drilling. Seafloor deposits (i.e., barium) from WBM drilling discharges were more widely dispersed than deposits at the two ESBM sites (>1,200 m vs 200 m). 	<ul style="list-style-type: none"> • The study concluded that the magnitude and persistence of environmental effects from discharge of drilling muds and cuttings range, in order of severity, from OBM to ESBM to WBM. OBM cuttings can persist on the Brunei seabed for over 13 years. • Biophysical effects on the seabed from both WBM and ESBM were similar and resulted primarily from smothering of benthic organisms by sedimentation and anoxic conditions due to bacterial decomposition within the cuttings piles. • Generally, WBM effects were more widely dispersed (>1,200 m) but exhibited indications of faster benthos recovery (within 3 years) than ESBM (typically dispersed within 200 m). • Degradation of organic inputs from drilling muds appears to be accelerated in shallow water characterized by high wave and current energy, due to increased oxygenation of sediments.

Summary of Recent Mud and Cuttings Offshore Discharge EEM Studies

<p>Study: Laboratory Exposures of Invertebrate and Vertebrate Species to Concentrations of IA-35 (Petro-Canada) Drill Mud Fluid, Production Water, and Hibernia Drill Mud Cuttings (Payne et al., DFO, 2001)</p>	<p>Description: Various laboratory tests were conducted on the short term effect of synthetic drill mud fluid, produced water and drill mud cuttings on brine shrimp nauplii, capelin larvae, marine copepods, juvenile yellowtail flounder and ctenophores.</p>	
<p>Physical and Chemical Effects</p>	<p>Biological Effects</p>	<p>General Comments/Conclusions</p>
<ul style="list-style-type: none"> • The results support the hypothesis that the wastes pose little or no risk of an acute toxic nature to the marine environment. 	<ul style="list-style-type: none"> • The studies indicated a very low acute toxicity potential for drill mud fluid, production water and drill cuttings for the species and life stages tested. 	<ul style="list-style-type: none"> • A number of studies were carried out on plankton, fish larvae and juvenile fish to investigate the acute toxicity potential of SBM/cuttings and production water. • Acute toxicity potentials were demonstrated to be very low indicating that the wastes pose little or no risk of an acute toxic nature to the marine environment.

NOTES

NOTES

NOTES
