Environmental
Studies
Research
Funds

187

Proceedings of a Workshop
on Seismic Sound Propagation
Characteristics in the
Beaufort Sea, Calgary,
Alberta, 14-15 July 2009

**PROCEEDINGS OF A WORKSHOP ON SEISMIC SOUND
PROPAGATION CHARACTERISTICS IN THE BEAUFORT SEA,
CALGARY, ALBERTA, JULY 14-15, 2009**

by



for

**Environmental Studies Research Funds
Calgary, Alberta**

**LGL Project No. SA1039
September 2010**

**PROCEEDINGS OF A WORKSHOP ON SEISMIC SOUND
PROPAGATION CHARACTERISTICS IN THE BEAUFORT SEA,
CALGARY, ALBERTA, JULY 14-15, 2009**

by

LGL Limited
environmental research associates
388 Kenmount Road, Box 13248, Stn. A
St. John's, NL A1B 4A5
Tel: 709-754-1992
vmoulton@lgl.com
www.lgl.com

for

Environmental Studies Research Funds
444 7th Avenue S.W.
Calgary, Alberta
T2P 0X8

LGL Project No. SA1039
September 2010

Correct citation for this report is:

Moulton, V.D. and W.J. Richardson. 2010.
Proceedings of a Workshop on Seismic Sound Propagation Characteristics in the Beaufort Sea, Calgary, Alberta, July 14-15, 2009.
Environmental Studies Research Funds Report No. 187. Calgary. 47 p.

The Environmental Studies Research Funds are financed from special levies on the oil and gas industry and administered by Natural Resources Canada for the Minister of Natural Resources Canada and the Minister of Indian Affairs and Northern Development.

The Environmental Studies Research Funds and any person acting on their behalf assume no liability arising from the use of the information contained in this document. The opinions expressed are those of the authors and do not necessarily reflect those of the Environmental Studies Research Funds agencies. The use of trade names or identification of specific products does not constitute an endorsement or recommendation for use.

Published under the auspices of the
Environmental Studies Research Funds
NE22-4/187E-PDF

Table of Contents

	Page
Table of Contents	iii
List of Appendices	iv
Executive Summary	v
Introduction.....	1
Background.....	1
Goals and Objectives	2
Approach.....	2
Participants.....	3
Introduction.....	4
Contexte	4
Buts et objectifs.....	5
Approche.....	5
Participants.....	6
Workshop Day One.....	8
Formal Presentations.....	8
Introduction.....	8
Sound Metrics: Relevant to Airgun Sounds.....	12
Modelling of Predicted Airgun Sound Levels	15
Empirical Measurements of Airgun Sounds	26
Modelling and Empirical Comparisons	31
Underwater Sound from On-Ice Vibroseis	33
Workshop Day Two.....	33
Top Eight Data Gaps and Procedural Issues.....	34
Key Data Gaps/Procedural Issues and Recommended Studies	35
Sound Metrics: Relevant to Airgun Sounds.....	36
Rapporteur: Dr. Bill Streever (BP)	36
Data Gap/Procedural Issue.—Workshop participants felt that there was a need for better sharing of information about sound metrics relevant to airgun pulses and marine mammals, and related mitigation measures (i.e., safety zones), between industry organizations, regulators, and media representatives to minimize misunderstandings about key issues.	36
Propagation Modelling in Beaufort Sea Conditions	37
Impact Radii and CSEL Approaches	39
Summary and Conclusions	41
References and Reviews	43
Acknowledgements.....	46
Dedication.....	47

List of Appendices

Appendix A: List of Acronyms and Key Definitions	A-1
Appendix B: Workshop Agenda.....	B-1
Appendix C: List of Workshop Participants.....	C-1
Appendix D: Data Gaps and Procedural Issues	D-1
Sound Metrics: Relevant to Airgun Sounds.....	D-1
Modelling of Predicted Airgun Sound Levels	D-2
Empirical Measurements of Airgun Sounds	D-4
Modelling vs. Empirical Comparisons	D-6
On-Ice Vibroseis	D-6
Appendix E: Presentations.....	E-1

Executive Summary

The Environmental Studies Research Funds (ESRF) recognized that with the granting of new exploration leases in the Canadian Beaufort Sea in recent years, hydrocarbon exploration using 2-D and 3-D marine seismic programs would continue. A key issue concerning seismic surveys in the Beaufort Sea is the effect of underwater sound generated by airgun arrays on bowhead whales (*Balaena mysticetus*) and beluga whales (*Delphinapterus leucas*) that use the area for feeding and migration. In addition, the effect of seismic survey sound on the accessibility of belugas to Inuvialuit hunters is a key concern.

In recent years, as part of mitigation procedures to reduce potential effects of seismic survey sound on marine mammals, it has been common for seismic programs conducted in the Canadian (and U.S.) Beaufort Sea to include a “shutdown” requirement for cetaceans within a “safety zone”, i.e., within a distance from the airgun array at which the received level of underwater sounds is expected to be ≥ 180 dB re 1 μ Pa (rms). Seismic operators in the Canadian Beaufort Sea have conducted pre-season acoustic modelling studies to determine appropriate safety zones for whales. These modelling results, which attempt to allow for various environmental parameters that affect underwater sound propagation, have typically been verified by acquiring acoustic data in the field at the start of a seismic program. Although some of the factors that affect sound propagation in the Beaufort Sea are well known, it has become increasingly obvious that there are numerous uncertainties and data gaps that limit the confidence in, and to some degree the accuracy of, acoustic modelling predictions.

As a first step toward the implementation of “a study of seismic sound characterization” in the Beaufort Sea, the ESRF Management Board recommended that a workshop be held. In spring 2009, the ESRF contracted LGL Limited to help organize and facilitate the workshop. The emphasis of the workshop was to be mainly on empirical measurements and modelling of underwater sounds from marine seismic surveys involving airgun arrays, the most appropriate ways in which to measure these sounds (“metrics”), associated data gaps, and recommended studies. The workshop was held on July 14 and 15 in Calgary, Alberta, Canada. Twenty-four people attended the workshop. Experts in physical acoustics, particularly individuals with experience conducting empirical measurements and modelling of seismic survey sounds in the Canadian and Alaskan Beaufort Sea, presented findings from their work and discussed the limitations and data gaps. Experts included the following:

- Dr. William C. Burgess, Greeneridge Sciences
- Dr. Susanna B. Blackwell, Greeneridge Sciences
- Dr. John Diebold, Lamont-Doherty Earth Observatory
- Dr. William T. Ellison, Marine Acoustics Inc.
- Melania Guerra, Scripps Institute of Oceanography
- David E. Hannay, JASCO Applied Sciences
- Michael R. Jenkerson, ExxonMobil
- Dr. Roberto Racca, JASCO Applied Sciences
- Dr. W. John Richardson, LGL Limited (also facilitator of the workshop)

In addition, there were participants from industry and elsewhere with considerable expertise on seismic operations in the Beaufort Sea who contributed to discussion periods.

Day One of the workshop focused on presentations by experts on aspects of the following topics: Sound Metrics Relevant to Airgun Sounds, Modelling of Predicted Airgun Sound Levels, Empirical Measurements of Airgun Sounds, and Pre-season Modelling and Empirical Comparisons. After the presentations on each topic, discussion was encouraged. Insofar as possible, discussion focused on identifying data gaps and procedural issues. Day Two of the workshop involved further discussion of data gaps, including narrowing down a long list of gaps identified on Day One into shorter lists. After considerable discussion and several rounds of voting by workshop participants, a single list of the most important and relevant data gaps pertaining to seismic survey sound propagation in the Beaufort Sea was adopted. With guidance from the ESRF, the participants were instructed to select the top three data gaps in order to build a suggested study design for each of these gaps. Workshop participants were then divided into three breakout groups to outline a study design for each of the three key data gaps and procedural issues. These three designs were presented to all participants at the end of Day Two.

Workshop participants identified (using a voting procedure) the following top three data gaps and procedural issues (in no particular order):

1. A need for better sharing of information between industry organizations and regulators concerning (a) sound metrics relevant to airgun pulses and (b) related mitigation measures for marine mammals (i.e., safety zones or impact radii).
2. A need for better site-specific information on geoacoustic properties of the bottom of the Beaufort Sea, along with accurate water depth and Sound Velocity Profile (SVP) data, as inputs for sound propagation modelling.
3. A need to examine mitigation approaches relating to impact radii currently applied in the Canadian Beaufort Sea in comparison to those used or recommended elsewhere.

The breakout group addressing data gap and procedural issue (1) noted that some regulators, industry representatives, media representatives, and other stakeholders do not have a firm grasp of issues related to potential impacts of underwater sounds associated with geophysical surveys and that this often leads to misunderstandings about key issues. The group recommended that a computer-based instructional package with modules on geophysical surveys, underwater sound, marine mammal biology, potential impacts, and mitigation and monitoring should be developed. They noted that the instructional package should be easily understood and have a capacity for user interaction. The instructional package, if properly designed and distributed, would result in better informed participants in the regulatory process, who would be operating from a common knowledge base.

Geoacoustic data are key parameters in acoustic propagation models. The breakout group addressing data gap and procedural issue (2) noted numerous types of additional data that are needed for the Canadian Beaufort Sea, including more comprehensive data on bathymetry, subsea permafrost distribution, bottom type, bottom roughness, under ice roughness, SVP in the water column, SVP in the seafloor, and density profiles in the seafloor. A two-pronged approach to address this data gap was suggested, including the creation of a geoacoustics parameter

catalogue for the Canadian Beaufort Sea and a modelling sensitivity study. The creation of the catalogue would involve a search for and compilation of existing geoacoustic data from various sources including previous studies by industry and government. It would allow for easy access to information and for examination of important spatial and temporal data gaps by groups conducting propagation modelling. A modelling sensitivity study would investigate the importance of geoacoustic parameters in terms of the influence of each parameter on predicted sound levels in the water. The completion of the geoacoustics parameter catalogue and the modelling sensitivity study would allow researchers to make recommendations for directed field studies to address identified data gaps.

The breakout group addressing data gap and procedural issue (3) noted that widely varying mitigation approaches, monitoring requirements, and impact criteria are applied in different jurisdictions. Even within different Canadian regions, there were differences. Hence, there is a need to take a broad look at the approaches, particularly for impact radii, currently applied in the Canadian Beaufort Sea in comparison to those used or recommended for use elsewhere. It was recommended that this topic be addressed in an office-based review, analysis and integration of existing information and ideas in a variety of relevant fields. Emphasis should be on how impact radii could be defined in terms of sound levels and distance. However, this would necessarily require discussion of broader operational, physical acoustics, and biological issues. The study should include a review of current practices in Canada (especially but not exclusively in the Beaufort Sea region) in relation to approaches elsewhere in the world where impact radii have been specifically implemented or recommended. Limited additional modelling work would probably be required when assessing whether mitigation based on cumulative sound exposure level (CSEL) might be preferable to mitigation based on sound exposure at closest point of approach (CPA), and if so, how mitigation radii allowing for CSEL might be defined, and how they would compare with radii based on maximum single-pulse exposures.

All three recommended studies would help regulators provide support for a more scientifically defensible, understandable, and biologically relevant monitoring and mitigation approach for seismic surveys in the Beaufort Sea.

Introduction

This document includes the proceedings of an Environmental Studies Research Funds (ESRF) workshop held in Calgary, Alberta, on July 14-15, 2009, to investigate the topic of seismic survey sound propagation in the Beaufort Sea. LGL Limited, environmental research associates (LGL), was contracted to help organize and facilitate the workshop and prepare the proceedings document. The proceedings are presented in chronological order to help the reader follow the sequence of presentations, events and discussions that shaped the workshop and led to the recommended studies described in the report. Brief summaries of the presentations are included. The recommended studies, as formulated by the workshop participants, address the top three data gaps and procedural issues as voted upon by participants. To aid the reader, Appendix A provides a list of acronyms and definitions of key technical terms used in this document. Appendix D includes the long list of data gaps and issues from which the “top three” were selected. Appendix E provides the presentations that were given by various workshop participants and which are summarized earlier in the Proceedings.

Background

This workshop was held to address physical acoustics questions pertaining to the characteristics, propagation, and received levels of seismic survey sound in the Canadian Beaufort Sea. The emphasis was mainly on empirical measurements and modelling of underwater sounds from marine seismic surveys involving airgun arrays,¹ the most appropriate ways in which to measure these sounds (“metrics”), associated data gaps, and recommended studies. The workshop was not intended to focus on the known and hypothesized effects of such sounds on marine mammals. However, effects on marine mammals and on their accessibility to Inuvialuit hunters are key reasons for interest in the physical acoustic properties of seismic survey sounds in the Canadian Beaufort Sea, and for context, that topic was addressed briefly near the start of the workshop.

The Canadian Beaufort Sea is the primary foraging area for the Bering-Chukchi-Beaufort population of bowhead whales (*Balaena mysticetus*), and for a large population of beluga whales (*Delphinapterus leucas*). These belugas use the shallow waters of the Mackenzie estuary every summer and also range widely over the continental shelf and deeper waters of the Beaufort Sea. Beluga whales are an important subsistence food for Inuvialuit, just as bowhead whales are harvested by Inupiat in the Alaskan Beaufort Sea. Seismic sound exposures associated with the onset of specified biological effects vary widely and are not well documented for many marine mammal species and situations. However, there are more data for the most common species of marine mammals occurring in the Beaufort Sea than for the majority of other marine mammal species (see *Biological and Regulatory Context: A Brief Introduction* for an overview).

It is recognized that in order to predict and measure sound exposure meaningfully, well-defined and biologically relevant measurements of received sound are needed. Also, there is a need to understand the relationships of various sound measurements to one another, and to the factors

¹ Vibroseis, or the use of mechanical vibrators on landfast ice, is another seismic survey source that is frequently used as a geophysical assessment tool for oil and gas companies, particularly in the U.S. Beaufort Sea. Vibroseis was not discussed in detail during this workshop.

that affect source and received sound levels. The biological and regulatory issues were not the direct subject of this workshop. However, predicting and measuring levels of airgun array sound in meaningful and consistent ways is central to interpreting the biological effects of those sounds, and to establishing appropriate regulatory procedures.

The ESRF invited experts in physical acoustics, particularly individuals with experience conducting empirical measurements and modelling of seismic survey sounds in the Canadian and Alaskan Beaufort Sea, to come to Calgary in July 2009 to present findings of their work and to discuss relevant data gaps and procedural issues. In addition, there were participants from industry and elsewhere with considerable expertise on seismic operations and biological effects in the Beaufort Sea and elsewhere; they contributed to discussion periods, particularly those pertaining to recommended studies. ESRF representatives informed workshop participants that the ESRF intended to provide support for one of the studies recommended at the workshop.

Goals and Objectives

The ESRF outlined three objectives for the workshop.

1. A review and compilation of the available information on sound propagation in the Beaufort Sea related to seismic exploration;
2. The identification of knowledge gaps related to seismic sound propagation characteristics both in shallow nearshore waters and deeper offshore waters; and
3. The development of an experimental design to address those knowledge gaps.

Approach

The ESRF and LGL had discussions prior to the workshop to decide upon discussion topics that would help address the objectives outlined in the previous section. The following topics were deemed appropriate:

1. Sound Metrics: Relevant to Airgun Sounds
2. Modelling of Predicted Airgun Sound Levels
3. Empirical Measurements of Airgun Sounds
4. Pre-season Modelling and Empirical Comparisons
5. Underwater Sound from On-Ice Vibroseis

A non-conventional approach was used to develop the workshop agenda (see Appendix B for the agenda) and address objectives 1 and 2. On Day 1 of the workshop, a “primary” presenter spoke on a given topic; in most cases this presenter was allotted 15–20 min to speak. After most primary presentations, one to three “follow-up” presenters each talked briefly (5–10 min) about additional aspects of the topic. The rationale for this approach was that many key contributors attending the workshop had expertise on more than one topic. Therefore, it was more appropriate to organize the agenda by relevant topics and questions rather than by individual presenters (most of whom could contribute valuable information on multiple topics).

After the presentations on each topic were given, discussion was encouraged. Insofar as possible, discussion focused on identifying data gaps and procedural issues pertaining to a given topic as part of that topic's discussion time rather than deferring the entire discussion of data gaps until after all of the presentations had been given. Besides the presenters, there were participants from industry and elsewhere with considerable expertise, and all participants were encouraged to participate in the discussion periods.

Day 2 of the workshop involved further discussion of data gaps and issues, including narrowing down the rather long list of gaps identified on Day 1 into shorter lists. Short lists were established for four of the five workshop topics (with the exception of on-ice Vibroseis; workshop participants agreed that a lack of publically available information precluded further discussion on this topic). After considerable discussion and several rounds of voting by workshop participants, a single list of the eight most important data gaps pertaining to seismic survey sound propagation in the Beaufort Sea was adopted. With guidance from the ESRF, the participants were instructed to select the top three data gaps in order to build a suggested study design around each of these gaps. Workshop participants were divided into three breakout groups to flesh out these study designs. These three designs were presented by breakout group rapporteurs to all participants at the end of Day Two.

Participants

Workshop participants consisted of scientists, industry representatives (particularly companies with operations in the Beaufort Sea), and ESRF representatives. In total, there were 24 participants. A complete list of workshop participants is provided in Appendix C. Dr. W. John Richardson of LGL was the facilitator of the workshop, assisted by Valerie Moulton of LGL.

Formal presentations were given by nine invited scientists with experience in studies of the characteristics and acoustic propagation of seismic survey sounds. Many of these scientists had particularly relevant experience in both the Canadian and Alaskan Beaufort Sea. The scientists gave presentations on the first day of the workshop; this allowed all participants to become familiar with the current state of knowledge on the topic. Presenters and their affiliations are listed below.

- Dr. William C. Burgess, Greeneridge Sciences
- Dr. Susanna B. Blackwell, Greeneridge Sciences
- Dr. John Diebold, Lamont-Doherty Earth Observatory
- Dr. William T. Ellison, Marine Acoustics Inc.
- Melania Guerra, Scripps Institute of Oceanography
- David E. Hannay, JASCO Applied Sciences
- Michael R. Jenkerson, ExxonMobil
- Dr. Roberto Racca, JASCO Applied Sciences
- Dr. W. John Richardson, LGL Limited

Introduction

Ce document contient les travaux de l'Atelier du Fonds pour l'étude de l'environnement (FEE) tenu à Calgary, Alberta, les 14 et 15 juillet 2009, portant sur l'étude de la propagation acoustique des levés sismiques dans la mer de Beaufort. LGL Limited, partenaire des études environnementales (LGL), a été engagé pour participer à l'organisation et à l'exécution de l'atelier et pour la préparation du document sur les travaux. Les travaux sont présentés en ordre chronologique afin d'aider le lecteur à suivre l'ordre des présentations, des événements et des discussions qui eurent lieu pendant l'atelier et qui ont mené aux recommandations d'études présentées dans le rapport. Les comptes-rendus des présentations sont inclus. Les études recommandées, telles que formulées par les participants, traitent des trois plus importantes lacunes et questions de procédure sélectionnées par les participants. Pour faciliter la lecture, l'Annexe A contient une liste des acronymes et des définitions des principaux termes techniques utilisés dans le présent document. L'Annexe D contient la liste complète des lacunes et des questions en matière de données à partir desquelles les trois plus importantes ont été sélectionnées. L'Annexe E dresse la liste des différentes présentations des participants de l'atelier et qui sont résumées précédemment dans les procès-verbaux.

Contexte

Cet atelier a été organisé pour régler les problèmes acoustiques physiques liés aux caractéristiques, à la propagation et aux niveaux sonores reçus lors des levés sismiques dans les eaux canadiennes de la mer de Beaufort. L'accent a été mis principalement sur les mesures empiriques et la modélisation des sons sous-marins provenant des levés sismiques à l'aide de canons à air,² cela étant la technique la plus appropriée pour mesurer ces sons (« paramètres »), les données manquantes connexes et les études recommandées. L'atelier ne cherchait pas à se concentrer sur les effets connus et hypothétiques de ces sons sur les mammifères marins. Cependant, les effets sur les mammifères marins et leur accessibilité aux chasseurs Inuvialuit sont les principales causes d'intérêt dans les propriétés acoustiques physiques des sons des levés sismiques dans la mer de Beaufort, et pour le contexte, ce sujet a été survolé rapidement au début de l'atelier.

La mer de Beaufort est la principale aire de chasse de la population de baleines boréales (*Balaena mysticetus*) de Béring-Chukchi-Beaufort et d'une grande population de bélugas (*Delphinapterus leucas*). Ces bélugas utilisent les eaux peu profondes de l'estuaire du Mackenzie chaque été et peuvent être aperçus sur la plate-forme continentale et dans les eaux les plus profondes de la mer de Beaufort. Le béluga constitue une source d'alimentation importante pour l'Inuvialuit, tout comme les baleines boréales qui sont chassées par les Inupiat dans la mer de Beaufort de l'Alaska. L'exposition aux sons sismiques associée à l'apparition d'effets biologiques spécifiques varie énormément et n'est pas très bien documentée pour plusieurs mammifères et milieux marins. Toutefois, il existe davantage de données pour les espèces les plus courantes de mammifères

² La méthode vibrosismique, ou l'utilisation de vibrateurs mécaniques sur la glace de rive, est une autre méthode d'étude sismique fréquemment utilisée comme outil d'évaluation géophysique pour les sociétés pétrolières et gazières, particulièrement dans la mer de Beaufort américaine. La vibrosismique n'a pas été abordée en détail pendant l'atelier.

marins présents dans la mer de Beaufort que pour la majorité des autres mammifères marins (voir *Biological and Regulatory Context: A Brief Introduction* pour un aperçu).

Il est reconnu que, dans le but de prévoir et de mesurer l'exposition sonore de manière significative, des mesures bien définies et biologiquement pertinentes du son reçu sont nécessaires. De plus, il est nécessaire de comprendre les liens entre les différentes mesures du niveau sonore, et avec les facteurs qui influent sur la source et les niveaux sonores captés. L'atelier n'a pas traité directement des questions biologiques et réglementaires. Cependant, la prédiction et le calcul des niveaux sonores des canons à air de façon significative et pertinente sont essentiels pour l'interprétation des effets biologiques de ces sons et pour établir les procédures réglementaires appropriées.

Les spécialistes en physique acoustique invités par le FEE, particulièrement ceux possédant de l'expérience avec les mesures empiriques et la modélisation des émissions sonores des études sismiques dans la mer de Beaufort canadienne et de l'Alaska, se sont présentés à Calgary en juillet 2009 pour présenter les résultats de leurs travaux et pour discuter d'importantes lacunes et de questions de procédures en matière de données. De plus, des partenaires en provenance de l'industrie et d'ailleurs, possédant une expertise considérable à propos des levés sismiques et des effets biologiques dans la mer de Beaufort et ailleurs, ont contribué aux périodes de débat, particulièrement ceux en rapport avec les études recommandées. Les représentants du FEE ont informé les participants que le FEE prévoyait offrir son appui à l'une des études recommandées au cours de l'atelier.

Buts et objectifs

Le FEE décrit les trois objectifs de l'atelier.

4. L'examen et la compilation des renseignements disponibles relatifs à la propagation acoustique dans la mer de Beaufort en rapport avec l'exploration sismique;
5. Cerner les lacunes liées aux caractéristiques de la propagation acoustique sismique dans les eaux littorales peu profondes et dans les eaux du large profondes;
6. L'élaboration du concept expérimental pour traiter les lacunes.

Approche

Le FEE et LGL ont entretenu des discussions avant la tenue de l'atelier pour décider les sujets des débats qui contribueraient à atteindre les objectifs décrits dans la partie précédente. Les sujets suivants ont été retenus :

6. Paramètres sonores correspondant aux sons des canons à air
7. Modélisation des niveaux sonores prévus des canons à air
8. Mesures empiriques des sons des canons à air
9. Modélisation avant saison et comparaisons empiriques
10. Sons sous-marins causés par la méthode vibrosismique sur glace

Une méthode peu commune a été utilisée pour dresser l'ordre du jour de l'atelier (voir l'Annexe B pour l'ordre du jour) et pour répondre aux objectifs 1 et 2. Le premier jour de l'atelier, un présentateur « principal » a discuté d'un sujet donné; dans la plupart des cas, ce présentateur disposait d'une période de 15 à 20 minutes pour parler. Après la plupart des présentations principales, d'un à trois présentateurs « complémentaires » venaient parler brièvement (cinq à dix minutes) d'autres aspects du sujet. La justification de cette approche est que de nombreux intervenants clés participant à l'atelier possédaient une expertise sur plus d'un sujet. Par conséquent, il était plus approprié d'organiser l'ordre du jour en fonction de sujets pertinents et de questions pertinentes plutôt qu'en fonction des présentateurs individuels (dont la plupart pouvaient fournir des informations précieuses sur de nombreux sujets).

Une fois les exposés sur chaque thème terminés, la discussion était encouragée. Dans la mesure du possible, la discussion était axée sur l'identification des lacunes dans les données et des questions de procédure relatives à un sujet donné dans le cadre de la discussion de ce sujet plutôt qu'après toutes les discussions relatives aux lacunes dans les données après la présentation de l'ensemble des exposés. Outre les conférenciers, il y avait des participants de l'industrie et d'ailleurs, possédant une expertise considérable, et tous les participants étaient encouragés à participer aux périodes de discussion.

Le deuxième jour de l'atelier consistait en d'autres discussions sur les lacunes et les questions, y compris la réduction de la liste relativement longue des lacunes cernées lors de la première journée. Les listes réduites ont été fixées à quatre des cinq thèmes de l'atelier (à l'exception de la vibrosismique sur glace; les participants à l'atelier ont convenu que le manque d'information disponible au public empêchait la discussion sur ce sujet). Après de longues discussions et plusieurs tours de vote par les participants, une liste des huit lacunes les plus importantes relatives à la propagation acoustique des levés sismiques dans la mer de Beaufort a été adoptée. Avec l'aide du FEE, les participants ont été invités à sélectionner les trois lacunes qui permettraient d'établir le plan d'étude proposé autour de chacune de ces lacunes. Les participants à l'atelier ont été divisés en trois petits groupes pour donner corps à ces plans d'étude. Les rapporteurs des petits groupes de discussion ont présenté ces trois modèles à tous les participants à la fin de la deuxième journée.

Participants

Les participants à l'atelier regroupaient des scientifiques, des représentants de l'industrie (particulièrement des entreprises opérant dans la mer de Beaufort) et les représentants du FEE. Au total, il y avait 24 participants. Une liste complète des participants à l'atelier est fournie à l'Annexe C. M. W. John Richardson de LGL était l'animateur de l'atelier, aidé par Valerie Moulton de LGL.

Neuf exposés officiels ont été présentés par neuf scientifiques invités ayant de l'expérience dans l'étude des caractéristiques et de la propagation acoustique du son des levés sismiques. Beaucoup de ces scientifiques avaient de l'expérience particulièrement pertinente avec la mer de Beaufort, tant au Canada qu'en Alaska. Les scientifiques ont présenté des exposés le premier jour de l'atelier, ce qui a permis à tous les participants de se familiariser avec l'état actuel des connaissances sur le sujet. Les présentateurs et leurs affiliations sont énumérés ici :

- M. William C. Burgess, Greeneridge Sciences
- M^{me} Susanna B. Blackwell, Greeneridge Sciences
- M. John Diebold, Observatoire terrestre Lamont-Doherty
- M. William T. Ellison, Marine Acoustics Inc.
- Melania Guerra, Scripps Institute of Oceanography
- David E. Hannay, JASCO Applied Sciences
- Michael R. Jenkerson, ExxonMobil
- M. Roberto Racca, JASCO Applied Sciences
- M. W. John Richardson, LGL Limited

Workshop Day One

Formal Presentations

The invited speakers gave presentations to familiarize workshop participants with the current state of knowledge of seismic survey sounds and their propagation, with emphasis on the Beaufort Sea. The presentations are summarized below and included in their entirety in Appendix E. Unless indicated otherwise, the presentation summaries provided below were prepared by the speakers who gave the specific talks. As noted earlier, data gaps and procedural issues were discussed after the presentations. A long list of data gaps and procedural issues identified on Day One of the workshop is provided in Appendix D. In addition, workshop participants asked questions about presentation content, and the key questions and answers are provided at the end of the summary of each primary talk/follow-up session.

Introduction

Biological and Regulatory Context: A Brief Introduction

Dr. W. John Richardson (LGL Limited, environmental research associates)

This workshop was intended to address physical acoustics questions pertaining to the characteristics, propagation, and received levels of seismic survey sounds in the Canadian Beaufort Sea. The emphasis was to be mainly on empirical measurements and modelling of underwater sounds from marine seismic surveys, the most appropriate ways in which to measure these sounds (“metrics”), associated data gaps, and recommended studies. The workshop was not intended to focus on the known and hypothesized effects of such sounds on marine mammals. However, effects on marine mammals and on their accessibility to Inuvialuit hunters are the main reasons for interest in the physical acoustic properties of seismic survey sounds. This introductory presentation was intended to provide some basic background concerning the biological and regulatory issues that might be relevant in judging which physical acoustics questions and metrics should receive priority.

Given the general nature of this presentation summary, most individual statements are not referenced. However, a list of some of the most relevant papers and reviews is included in the References and Reviews section of this document.

Categories of Known or Suspected Biological Effects

The known and potential biological effects of anthropogenic (man-made) sounds are commonly grouped into several categories, as follows:

1. Detection of sound by marine mammals
2. Masking (interference with) the detection of other relevant sounds
3. Behavioural disturbance, subtle or more pronounced
4. Auditory impairment, temporary or permanent
5. Other physiological issues? Stranding?

With the possible exception of the last of these categories, the levels of anthropogenic sound necessary to elicit these types of effects generally increase as one progresses down the list.

Detection: Marine mammals have auditory systems that are well adapted for detecting and characterizing underwater sound, so any anthropogenic sound strong enough to be detectable by our instruments will be detectable to at least some marine mammals. Background sound levels in the Beaufort Sea, on a $1/3^{\text{rd}}$ octave basis, are commonly in the 90–100 dB range, so any received airgun sound with a broadband level of 100 dB or more is likely to be detectable. Airgun pulses commonly have detectable levels at distances out to 10s of kilometres from the source, and sometimes (in deeper water) to 100s of kilometres. Seismic survey sounds have most of their energy at low frequencies (below 150 Hz), so they are presumably most prominent to baleen whales (like the bowhead whale) whose calls are at low frequencies and whose hearing systems are particularly adapted for hearing low-frequency sounds. Seals and toothed whales (like belugas) are better adapted for hearing medium- and high-frequency sounds, respectively. However, airgun pulses are sufficiently strong and contain sufficient energy at medium frequencies that these pulses will commonly be detectable to seals and toothed whales 10s of kilometres away. On the other hand, whether faint airgun sounds detected at long distances have any biologically significant effect on marine mammals is not well documented.

Masking is a natural phenomenon that all animals (and humans) deal with commonly. There is always some background sound (natural or man-made), and sounds of interest can only be detected if their levels are high enough such that they are not “masked” by the background sound. Compared with many other types of anthropogenic sounds, airgun sounds have less potential to mask other sounds relevant to marine mammals because airgun sounds are intermittent (typically emitted every 8–12 s). Other sounds of interest can usually be heard in the “gaps” between successive airgun pulses. However, there will at times be some masking even between pulses if there is appreciable long-lasting reverberation of the airgun pulses. In a few cases (not in the Beaufort Sea), it has been reported that airgun sounds become essentially continuous as a result of long-distance propagation, reverberation, and simultaneous operations by multiple seismic vessels, and in those cases masking would be more severe. In general, the zone around an operating seismic vessel where appreciable masking could occur is likely to be considerably smaller than the zone where the airgun pulses would be audible to a marine mammal. That zone may be determined as much or more by the continuous propulsion sounds from the seismic ship as by the intermittent airgun sounds.

Behavioural disturbance of marine mammals as a result of exposure to airgun pulses or other anthropogenic sound is quite a broad category. It can involve subtle alterations in behaviour that are only detectable (to us) through detailed statistical analysis of quantitative measurements of behaviour. At the other extreme, it can involve strong and perhaps long-lasting avoidance of an area ensonified by industrial noise. There is some positive correlation between received sound levels and the strength of the behavioural response, but this correlation is not precise. Behavioural responsiveness to a given sound type and level can vary considerably, depending on the activity of the animal, its prior experience with the sound, and other factors. It is common for marine mammals to be exposed to measurable and presumably detectable levels of airgun or other industrial sounds and not exhibit any obvious behavioural responses; exposure to low levels of industrial sound does not always cause overt disturbance. The likelihood (and severity)

of disturbance tend to increase as received level increases, although there is (as previously noted) considerable variability in responses to a given received sound level.

Response thresholds vary widely among and within species. Bowhead whales sometimes show avoidance of marine seismic operations at distances as great as 20–30 km, and subtler behavioural responses at even longer distances. These responses may occur upon exposure to received levels as low as 120–150 dB re 1 μPa (rms pressure measured over the pulse duration). At other times (especially when feeding), bowheads tolerate an operating seismic vessel as close as a few kilometres away, only reacting when received levels reach 160–170 dB or more. Beluga reactions have not been studied as much, but belugas (at least at times) also seem to avoid operating seismic vessels out to distances on the order of 10–20 km. Seals, on the other hand, appear to show no more than localized avoidance of an airgun array, often tolerating airguns operating well within 1 km, and sometimes within 100 m, where received levels may exceed 180–190 dB re 1 μPa (rms).

Auditory impairment can occur as a result of exposure of any mammal (including humans) to strong sounds. Temporary auditory impairment (often described as *Temporary Threshold Shift* or TTS) is a natural physiological response to exposure to strong sound, such as humans encounter when operating noisy power tools. If the exposure is not too severe or too prolonged, then after the sound exposure ends, the auditory impairment gradually diminishes and hearing sensitivity returns to normal. In recent years, levels and durations of sound necessary to cause TTS in certain toothed whales (including the beluga) and some pinnipeds have been measured, and the gradual return to normal hearing sensitivity has been documented. In the beluga, there is one measurement suggesting that TTS will occur upon exposure to a received energy level exceeding 186 dB re 1 $\mu\text{Pa}^2 \cdot \text{s}$, flat-weighted (Finneran et al. 2000). [Note that this is expressed as an energy level and is not directly comparable with previously-quoted rms sound pressure levels.] There are equally limited data suggesting that some other species (harbour porpoise, harbour seal) may incur TTS with considerably lower exposures. There are as yet no specific data on the levels of repetitive seismic pulses that are necessary to elicit TTS, but the available data suggest that some marine mammals within 10s or perhaps 100s of metres of an airgun array might incur TTS.

Of more concern is the possibility of *Permanent Threshold Shift* (PTS), i.e., permanent auditory damage and impairment. In terrestrial mammals (including humans), this can occur upon even a brief exposure to an extremely high level of sound, or upon prolonged exposure to somewhat lower (but nonetheless high) sound levels. There is no specific information documenting whether airgun sound can ever be strong enough to elicit PTS in any marine mammal. However, based on what is known about TTS vs. PTS relationships in terrestrial mammals, and TTS onset in marine mammals, there is concern that PTS might be possible in at least some marine mammals if they are very close to an operating airgun array (Southall et al. 2007; Gedamke et al. 2008). Southall et al. suggested that some cetaceans exposed to 198 dB re 1 $\mu\text{Pa}^2 \cdot \text{s}$ (accumulated across successive airgun pulses) might incur PTS, and other species including the harbour porpoise and harbour seal might incur PTS with less exposure. The specific circumstances in which a marine mammal might receive any specified amount of sound energy from a passing airgun array are difficult to define. They would depend not only on the 3-D sound field around the airgun array, the closest shotpoint to the animal, and the shot interval, but also on the animal's movements (horizontally and vertically) as the seismic vessel approaches and passes. Also, the 198 dB re 1 $\mu\text{Pa}^2 \cdot \text{s}$ cumulative

energy criterion is an estimate subject to many assumptions. The actual exposure that would result in PTS onset is unknown for all species, and probably quite variable.

Other physiological issues? Stranding? There has been speculation that exposure of marine mammals to anthropogenic sounds might lead, directly or indirectly, to a variety of adverse physiological phenomena including stress responses, gas-bubble disease (“the bends”), neurological disorders, tissue damage, and in extreme cases to death either at sea or by stranding. None of these phenomena has been confirmed to occur as a result of exposure to sounds from marine seismic surveys. The one case where stranding and death were most closely (in time and space) associated with a seismic survey involved deep-diving beaked whales in the Gulf of California, Mexico (Hildebrand 2005) — a situation not directly relevant to the Beaufort Sea whether or not the beaked whale deaths in Mexico had any connection with the seismic survey. Sound levels that might be necessary to elicit physiological problems or stranding, if these ever occur as a result of exposure to airgun sound, are unknown.

Current Real-Time Mitigation Practices

Mitigation procedures required in different jurisdictions vary widely, and often are not closely linked to current scientific knowledge (such as it is) about the effects of airgun sound on marine mammals.

One widely used criterion is the concept of a 500 m safety radius around the airgun array. Depending on the jurisdiction and type of marine mammal, there is often a requirement to avoid starting-up and/or to shut down an airgun array if a marine mammal is seen within that distance. The selection of 500 m rather than some other distance as the criterion distance was originally based mainly on the difficulties in sighting more distant animals—not on any specific knowledge about effects that might occur if mammals within 500 m are exposed to airgun sound. The received level of a sound pulse from an airgun array 500 m away varies widely depending on array size and configuration, operating depth, aspect, and sound propagation conditions (see for e.g., Moulton et al. 2009). A mammal 1,000 m from one airgun array may receive more sound than a mammal 500 m or even 250 m from some other array.

Some seismic surveys conducted under U.S. jurisdiction base mitigation practices on the distances within which received levels of single airgun pulses are expected to be 190, 180 and 160 dB re 1 μ Pa (rms). The 190 and 180 dB distances are considered “safety radii”. Cetaceans are not to be exposed to impulse sounds with received level ≥ 180 dB re 1 μ Pa (rms), and pinnipeds are not to be exposed to impulses ≥ 190 dB (rms). The 180 and 190 dB (rms) criteria are largely arbitrary; they were selected before there was any specific information from marine mammals concerning sound pressure or energy levels necessary to elicit TTS or PTS.

In the U.S., 160 dB re 1 μ Pa (rms) is often considered to be the level of impulse sound above which appreciable behavioural disturbance is likely. That criterion was based on early studies of baleen whale responses to airgun sound, but under U.S. regulatory procedures, is often assumed to apply to toothed whales and pinnipeds as well. The now-available behavioural-response data for those groups suggest that, for many dolphins and pinnipeds, overt behavioural reactions usually do not become evident until received levels substantially exceed 160 dB (rms).

Furthermore, now-available data from baleen whales (including bowhead whales) show that their response thresholds vary widely, with strong reactions sometimes occurring at received levels well below 160 dB (rms).

Summary and Conclusions

Seismic sound exposures associated with the onset of specified biological effects vary widely and are not well documented for many species and situations. However, there are more data for the most common species of marine mammals occurring in the Beaufort Sea than for the majority of other marine mammal species. To predict and measure sound exposure meaningfully, we need well-defined and biologically-relevant measures of received sound. There is a need to understand the relationships of different sound measures to one another, and to the factors that affect source and received sound levels. The most appropriate mitigation criteria may be best expressed using sound metrics different from those used at present, e.g., as sound energy level rather than sound pressure level or distance.

The biological and regulatory issues are not the direct subject of the present workshop. However, predicting and measuring levels of airgun array sound in meaningful and consistent ways is central to interpreting the biological effects of those sounds, and in establishing appropriate regulatory procedures.

Sound Metrics: Relevant to Airgun Sounds

Standardizing Methods of Measuring Underwater Noise

Michael R. Jenkerson, ExxonMobil (Primary Talk)

Extensive catalogues of industry sound data have been compiled for both seismic and non-seismic sources in the past several years.³ Behavioural data have also been collected in association with some of these acoustic data. However, in both cases, data acquisition and analysis have been performed using a variety of methods and metrics. Industry and the Joint Industry Program (JIP) plan to expand data collection for exploration and production (E&P) sound sources. As a first step, they want to identify standard methods for data acquisition (including appropriate equipment and methodology) and analysis (including appropriate correction factors and calibrations). This was done by establishing two working groups, which are also expected to determine the primary acoustic metrics that will be relevant for biological exposure assessments and estimates of biological significance. The use of such standards will ensure that results of JIP acoustic studies are reported consistently and that necessary supporting data are recorded and reported in a manner that will allow comparisons among studies. Several aspects will be considered when determining standards, including the following:

- Methodologies for the analysis of transient and continuous acoustic data,
- Methodologies for the analysis of velocity data,
- Recommendations on the use of calibrations, and

³ This summary was prepared by LGL from notes and audio recordings with a later review by M. Jenkerson.

- How to establish relationships between any new analysis metrics and those used in previous research as well as determining whether or not correction factors should be applied to data acquired or analysed in a non-standard manner.

At the time of this presentation (July 2009), a working group on analysis metrics, correction factors, and calibrations had met and was preparing draft standards that were undergoing (or would undergo) internal and external review. There were plans to release the standard within the JIP by mid-2010. The working group will determine whether these standards will be published in a peer-reviewed publication or possibly as a defined standard recognized by the American Standards Association (ASA). The possible adoption and publication of these standards by the ASA would occur sometime in the future.

A separate working group on acoustic acquisition equipment and methodology plans to prepare draft standards for internal and external review during 2010, with the objective of releasing a JIP standard by 2011.

Sound Pressure Metrics

David E. Hannay, JASCO Applied Sciences (Follow-up Talk)

Seismic airgun sources and vessels generate sounds that are emitted into the water and propagate through the ocean where they can be heard by marine mammals. Underwater sound levels are commonly characterized using the decibel scale. Decibels themselves are confusing enough, but further complexity arises from the use of several different metrics. Some metrics represent pressure and others energy-like characteristics of the sound field. Other metrics account for the hearing sensitivity of the listener (in this case, marine mammals) and this approach is now being included in some evaluations of seismic sounds. This presentation (see Appendix E, p. E-16 to E-25) started with a discussion of sound pressure and the decibel scale, and included a description of the common metrics in the geophysical industry: peak pressure and peak-to-peak pressure. It then discussed the root-mean-square pressure metric and how that is influenced by pulse duration. Then it addressed an energy-like metric referred to as sound exposure level (SEL). It then provided a discussion of cumulative sound exposure levels (CSEL), i.e., summing SEL across a sequence of received airgun pulses. The presentation concluded by summarizing how frequency-dependent hearing sensitivity is taken into account in the recently proposed cumulative M-weighted sound exposure level (CSEL) metric (Southall et al. 2007).

Sound Metrics

Dr. John Diebold, Lamont-Doherty Earth Observatory (L-DEO) of Columbia University (Follow-up Talk)

A variety of methods are used to characterize the strength of seismic source signals. Back projected (to nominal 1-m distance) peak, peak-to-peak, and total energy levels are the standards for comparing airgun arrays in the oil and gas exploration industry. However, most published research on acoustic avoidance behaviour of marine mammals has quantified the sound levels in terms of pressure at the receiver, measured over some time interval, and expressed as root-mean-square (rms) and converted to decibels. The rms metric is entirely appropriate for many acoustic signals recorded in the marine environment (shipping noise, long-pulse sonar, etc.), depending

on how the summation interval, T , is chosen. Although it is less appropriate for impulsive airgun signals, the “90% rms” measure has been used in many published studies and this practice has been continued so that meaningful comparisons could be made.

The biggest pitfall in the 90% rms measure is that the rms value for a given airgun signal can vary tremendously for signals with similar energy content, especially for noise-free modelled signals. The better the “tuning” of a seismic source array, the more impulsive its signature, the shorter its 90% energy window, and the higher the rms level, regardless of total energy content. [Particularly in directions other than vertically downward from the airgun array, the initially-brief impulse tends to become elongated in time as it propagates farther away from the source. For a given received energy level, the more prolonged the received pulse, the lower will be the rms pressure level averaged over the pulse duration.–W.J. Richardson, pers. comm.]

Other measures may be more appropriate for quantifying airgun signal levels and predicting their effect on marine fauna. Sound exposure level (SEL), a measure of energy flux density, is considered by many researchers to be a better predictor of hearing threshold shifts than is rms or peak level.

The question arises: if SEL is to be used as a proxy to rms for mitigation purposes, how are the SEL and rms levels related to one another, i.e., what value should be added to SEL to estimate the rms level for that received pulse? Suggested values include 10 dB and 15 dB. A difference of 15 dB corresponds to an rms integration window of about 32 ms, whereas 10 dB corresponds to 100 ms. [However, empirical measurements of airgun pulse parameters in different field situations have shown that there is no fixed offset between rms pressure levels measured in dB re 1 μPa and SEL values in dB re 1 $\mu\text{Pa}^2\cdot\text{s}$. The difference can range from well above 15 dB at certain times (usually close to the airgun array) to 0 dB or less in other situations (usually at long distance). RMS values tend to be notably higher than SEL values close to the source (where pulse duration is typically short), whereas at longer distances rms values tend to be progressively closer to the SEL values, and occasionally diminish below SEL values in situations where the pulse has become greatly elongated through propagation effects.–W.J. Richardson, pers. comm.]

Participants’ Questions

- *In deep water, empirical observations by L-DEO have shown that the offset between SEL and rms was high at shorter distances and became less at longer distances as the pulse expanded in length. Is this a general phenomenon and why didn’t it show up in shallow water?* In shallow water researchers are not looking just at direct arrival paths of pulses. Direct arrivals are much more likely to show that pattern when the receiver is to the side of an airgun string. In that case, there is one pulse from each string, and peaks are higher. From endfire aspects, energy from different airguns is received serially. The total energy is the same, but spread over a longer time, and peak sound levels are lower. Participants agreed that there is no single offset value that you can apply to convert from SEL to rms values, and vice versa. The numerical difference depends on water depth, distance from the source, and other factors.
- *What was the distance scale on the shallow water example provided in Dr. Diebold’s presentation?* 17 km.

- *Is NMFS (National Marine Fisheries Service) accepting the SEL or CSEL metric for regulatory purposes?* The regulatory processes for marine seismic sounds in the U.S. and in parts of Canada are still based on rms sound levels. It was noted that, in predicting safety radii, modellers often use models that estimate received levels on an SEL basis, requiring that some correction factor be applied to estimate the rms levels required by regulators.

Quantifying Masking Effects of Seismic Survey Reverberation off the Alaskan North Slope

Melania Guerra, Scripps Institute of Oceanography (Primary Talk)

Quantifying the potential long-term impacts of anthropogenic acoustic noise on marine life faces multiple challenges, beginning with the need to define standardized metrics to be extracted from acoustic signals. Some of the metrics currently utilized include peak-to-peak amplitude, rms amplitude, and the SEL, which quantifies the time-integrated square pressure of a signal.

One proposed approach for quantifying the potential for behavioural impact is to gauge the tendency of an anthropogenic signal to “mask” or interfere with the clear reception of other signals that are relevant to an animal’s long-term reproductive success and survival. For example, in shallow water environments in the Alaskan Beaufort Sea, a seismic survey airgun pulse interacts multiple times with the ocean surface and bottom, scattering energy incoherently throughout the water column in the form of reverberation. The received levels of reverberation can be much lower than peak or rms measurements of the direct pulse, but greater than natural ambient noise levels and can persist over times longer than the duration of the actual pulse. Thus, reverberation could play a role in masking communication between animals such as the bowhead whale.

Figure 1 shows a calibrated spectrogram of seismic survey sound as recorded by a Directional Autonomous Seafloor Acoustic Recorder (DASAR) in shallow water on September 9, 2008 (at 03:31). The spectrogram was computed using a 256-point Fast Fourier Transform (FFT) with 75% overlap, and it illustrates the received signal from the full-strength seismic array at a range of 6.5 km, generating pulses at 10-s intervals. Figure 1 provides some intuition into why measurements of reverberation are of interest. Although more than 95% of the airgun array energy is contained within the duration of the direct path and multipath arrivals, a small fraction of this energy persists as reverberation that can last several seconds after the direct-pulse arrival and sometimes lasting as long as into the next pulse. Conventional measurements of pulse SEL (or SPL) would ignore this reverberation contribution, but the Figure indicates that the reverberation levels are greater than ambient levels and persist for periods much longer than the transient pulse itself.

The proposed “reverberation” metric estimates the minimum levels of background noise that occur during impulsive noise activities, as a function of frequency and long-term time. Three time scales need to be defined to obtain this metric: the biologically-relevant energy-integration time scale of a species’ hearing mechanism (same as for an SEL calculation), the time-scale over

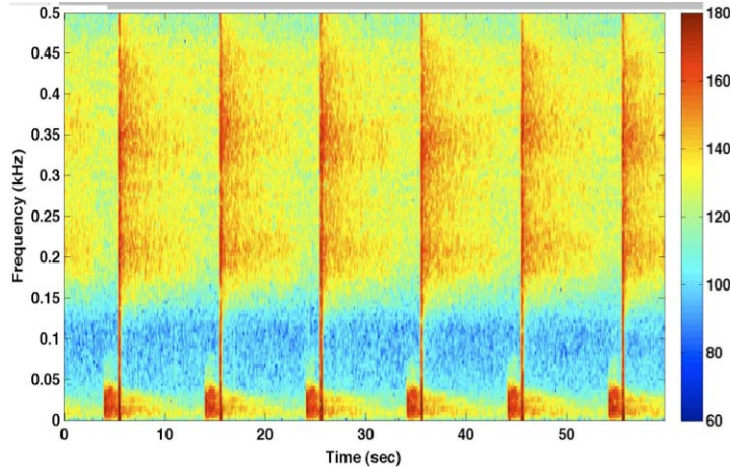

Figure 1. Representative spectrogram of sound from a full airgun array at 6.5 km range as recorded by a seafloor recorder (DASAR, Greene et al. 2004) in shallow water of the Alaskan Beaufort Sea.

which the stochastic reverberation can be considered wide-sense stationary (WSS), and the time scale over which significant secular changes take place in the source, receiver, or propagation characteristics of the environment. The resulting metrics are time-dependent estimates of the minimum values of background noise that occur between pulses. The units of this “reverberation” metric are identical to those of a standard SPL or SEL level: dB re $1\mu\text{Pa}$ for SPL, dB re $1\mu\text{Pa}^2 \cdot \text{s}$ for SEL.

To compute the reverberation metric in this analysis, a series of FFTs were computed, using 1,024-point snapshot sizes with 50% overlap between subsequent snapshots. A 1,024-point FFT corresponds to an energy integration time ΔT_i of 1.024 s, the approximate duration of an average bowhead whale call. To compute the reverberation metric, the time scale ΔT_{WSS} was selected to be 2 s and $\Delta T_{secular}$ was selected to be 1,800 s, or 30 min. Figure 2 displays the reverberation metrics, computed over narrow frequency ranges, characterizing the same site as the spectrogram from Figure 1. Each curve on these plots covers a 100 Hz bandwidth, with the top subplots displaying the lower frequency band and the bottom graph showing the higher frequency band calculations.

The long-term broadband reverberation metric shown in Figure 2 is influenced by changes in ambient noise level as well as the presence of reverberation from anthropogenic sources. Substantial changes in the broadband ambient background levels can be observed, varying by over 30 dB, but tend to occur at relatively slow rates (e.g., over the course of a day). By contrast, seismic surveys produce relatively rapid fluctuations in background levels over hour-long time scales, as the ship constantly varies its distance to a given receiver (DASAR) while “rastering” across the site. This sharp variation is emphasized by the fact that the vessel ceases or reduces airgun activity when it is reversing course, allowing background levels to be briefly restored to natural baselines.

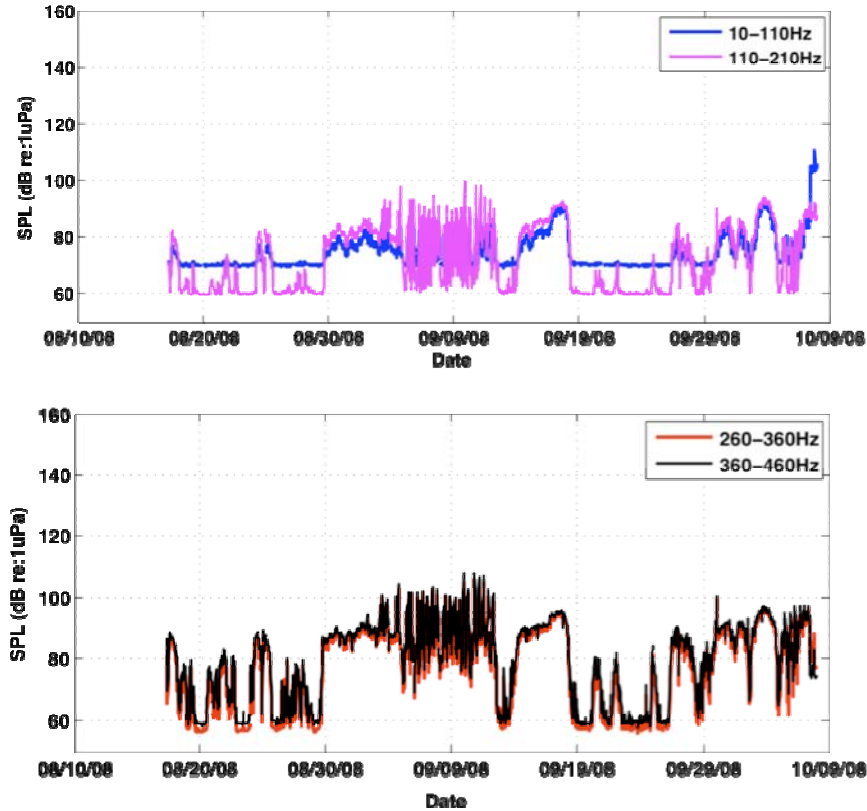

Figure 2. Narrowband reverberation metrics (SPL) for the same recorder location, over a five week duration: (a) 10-110 Hz and 110-210 Hz; (b) 260-360 Hz and 360-460 Hz. The following parameters were applied: an energy integration time of 1 s, wide-sense stationary averaging time of 2 s, and a secular time window of 30 min. Subsequent data windows are overlapped by 50%.

Thus, even without additional information about natural ambient background noise levels, one can easily identify a period of substantial seismic activity from the temporal pattern of reverberation levels alone. In general, the greatest levels attained by the seismic reverberation match or exceed the peak natural ambient noise detected during the entire deployment. Figure 2 also displays the reverberation metric as a function of frequency: the reverberation metric at this site is largest between 260 Hz and 460 Hz, which is consistent with what is visible in the spectrogram of Figure 1.

Figure 3 presents these results in two-dimensional images of the frequency and time dependence of the reverberation metric. In this case, the intensity of the metric is plotted as a function of date and frequency for each DASAR. The frequency dependence has been computed over eight overlapping (50%) frequency bands, each band covering a 100 Hz bandwidth, emphasizing a week of particularly intense seismic survey reverberation on September 20–28, 2008.

Figure 3 presents the frequency and time dependence of the reverberation metric at all recorders at five different sites. Reverberation effects from airgun pulses are clearly recognizable because of the “comb-like” pattern apparent in the reverberation metric, which arises as the seismic vessel rasters away and towards the acoustic recorders.

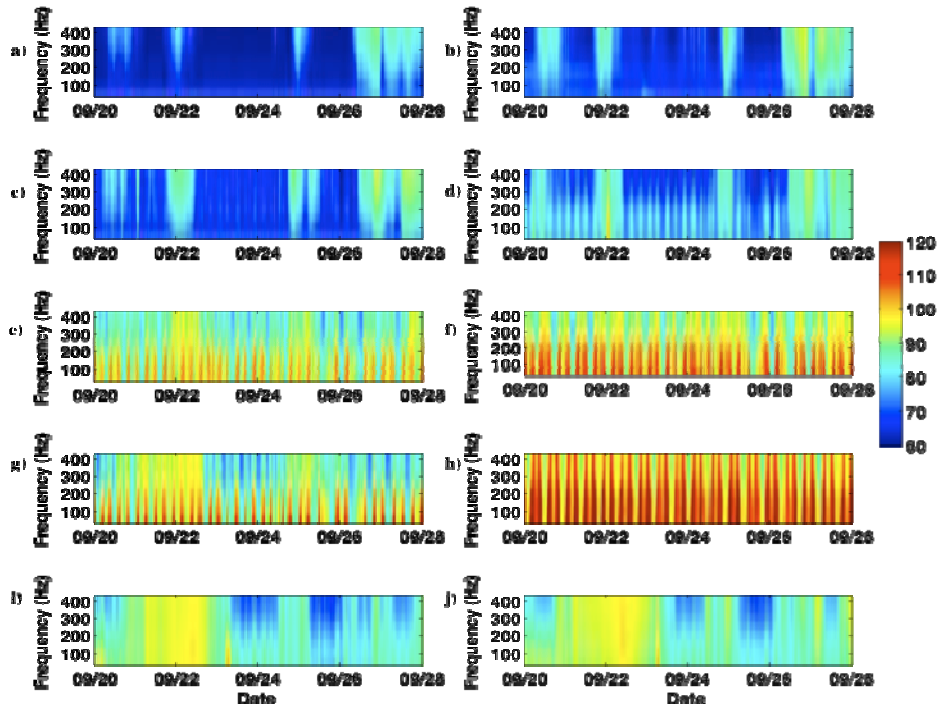

Figure 3. Expanded view of Figure 2 covering a period of peak seismic survey activity (September 20–28, 2008). The left column plots the reverberation metric (SPL units) of the shallowest recorder at each site; the right column plots the metric from the deepest recorder at each site. The rows correspond to five different recording sites, from 1 through 5.

For example, Figures 3f and 3h demonstrate how the reverberation levels intermittently rise and fall, while simultaneously weakening or strengthening at a different location as the vessel travels between these sites. Generally, the deeper DASARs (as depicted on the right side of Figure 3) experience more intense levels of reverberation than the shallow DASARs. Figure 3 shows that the seismic pulses originating between Sites 3 and 4 during the September 20–28 period produced the overall highest levels detected throughout the two-month period. Reverberation effects from this activity can be observed at Site 4, Site 3 (85 km away), and even at Sites 5 (93 km away) and 2 (128 km away).

In this analysis a relatively simple metric has been defined to characterize reverberation effects of impulsive anthropogenic noise in shallow water. A three-step procedure has been outlined for defining a “reverberation” metric, which requires three time scales to be selected. The application of this metric has been demonstrated on seismic signals recorded between 14-m and 53-m depths in the Alaskan Beaufort Sea in 2008. The data show that reverberation from seismic surveys with airguns can increase background noise levels at long ranges from the seismic activity.

Participants’ Questions

- *Under some conditions, it is difficult to differentiate between remaining reverberation and background noise, like weather-induced noise. Have you looked at the spectral composition of reverberation to see if something that remains uniquely identified as*

seismic pulse can be differentiated from, for example, ambient noise attributable to wind? Ms. Guerra noted that she had selected narrowband integrations to see if there was a spectral component, but she had not performed that analysis for wind. She noted that her study was a work in progress.

- *What is the reason for the “mowing the lawn” (i.e., “comb-like”) effect?* Ms. Guerra noted that she believed it was attributable to range dependent effects or perhaps orientation (aspect) of the source. As the vessel approached the receiver, the receiver picked up an increasing reverberation signal. It was noted that the data could be normalized by transmission loss.

Modelling of Predicted Airgun Sound Levels

Source Models for Airgun Arrays

Dr. John Diebold, L-DEO (Primary Talk)

To ensure that U.S. academic marine seismic surveys do not adversely affect marine wildlife stocks, federal regulations controlling the levels of sound to which those stocks may be exposed are closely followed by L-DEO, which operates R/V *Marcus G. Langseth*, the federally owned U.S. academic marine seismic research vessel. These procedures include establishment of various safety radii, which are defined by *a priori* modelling of the propagation of sound from the seismic source array. To provide realistic predictions, modelling must include free surface and array effects. This is best accomplished when the near field signature of each airgun array element is propagated separately to the far field, and the results summed there. The predicted far field signatures are analysed to characterize the source’s expected energy as a function of distance and direction.

In general, the exact travel time and distance for sound from an airgun in a seismic source array varies according to an observer’s position. Modelling can only be conducted correctly when near field source signatures are used, and when propagation along each pathway between the source and the observer is considered separately. There are two pathways per array element, corresponding to the direct and surface-reflected arrivals from that element. In L-DEO’s pre-mitigation modelling, each element’s near-field signal is appropriately scaled in amplitude and shifted in time according to the exact direct path distance. Then the process is repeated to produce the free surface “ghost” signal of each airgun, and the results are summed. To obtain the input near-field “notional” signatures, commercially available software is used: MASOMO, the marine source modelling package within Petroleum Geo-Services’ “Nucleus” software. This modelling software emulates the behaviour of many types of airguns—singly, in clusters and in arrays, which may include clusters. An individual modelling run must be conducted for each array configuration and towing depth.

The modelling procedure can be summarized as follows:

1. Define the airgun array in terms of the size and relative location of each airgun (x, y, z).
2. Create near field (“notional”) signatures for each airgun.
3. Decide upon a 2-D mesh of points, for example, within a plane intersecting the centre of the airgun array. A typical mesh is 100×50 points.

4. For each of the points in the mesh, calculate the signal that would be observed there when every airgun in the array is activated simultaneously.
5. For that signal, determine the desired metric: peak-to-peak dB, peak dB, rms dB, SEL dB, maximum psi, etc.
6. Contour the mesh.
7. Determine radii.

Most of the computational effort occurs in Step 4, which involves the following:

- a. For each of the airguns in the array, determine the distances and thus the acoustic transit time between the airgun and the mesh point, as well as the free surface ghost “image” of the airgun and the mesh point.
- b. Scale and shift this airgun’s near field signal, dividing by the point-to-point distance and moving forward in time according to transit time.
- c. Scale and shift the near field signal’s ghost image, as above, in addition to multiplying by the free surface reflection coefficient (typically between -0.9 and -0.95]
- d. Sum the results. For the R/V *Langseth*’s 36-airgun array, 72 scaled and shifted signals are created and summed for each mesh point.

The measure most commonly used for marine wildlife mitigation is rms pressure averaged over some measure of pulse duration. Although rms is an appropriate measure for lengthy signals, it is not a direct measure of the energy of a short, impulsive signal, and may not be a good indicator of its biological effects. When a comparison is made between rms and several other metrics, it is apparent that rms is the least consistent. In addition, the measurement of a single impulsive signal (whether on an rms basis or any other basis) does not provide any assessment of the cumulative effect of repeated pulses, as occurs during marine seismic surveys.

Source Models for Airgun Arrays

Dr. William T. Ellison, Marine Acoustics Inc. (Follow-up Talk)

The objective of this follow-up presentation was to focus on four aspects of airgun array source models by comparing outputs from the Comprehensive Acoustic System Simulation/Gaussian Ray Bundles (CASS/GRAB) model and the Gundalf acoustic model. The four aspects of airgun array source models addressed here included 3-D array directivity, horizontal beam patterns (at 50, 300, and 1,000 Hz), particle velocity field, and near field modelling issues for extended arrays. The array used in this modelling comparison is shown in Figure 4.

Figure 5 provides the 3-D Gundalf result for array directivity (in line) in a frequency vs. vertical angle plot. This Figure specifically focuses on selected destructive interference nulls in the pattern at 50 Hz (no nulls), 125 Hz (Ghost) and 300 Hz (strong lobe structure with nulls at 33° and 66°).

Figures 6 and 7 provide the CASS/GRAB beam patterns at these latter two frequencies replicating the Gundalf 3-D pattern and showing, respectively, the downward Ghost at 125 Hz, and the Nulls at 33° and 66° at 300 Hz.

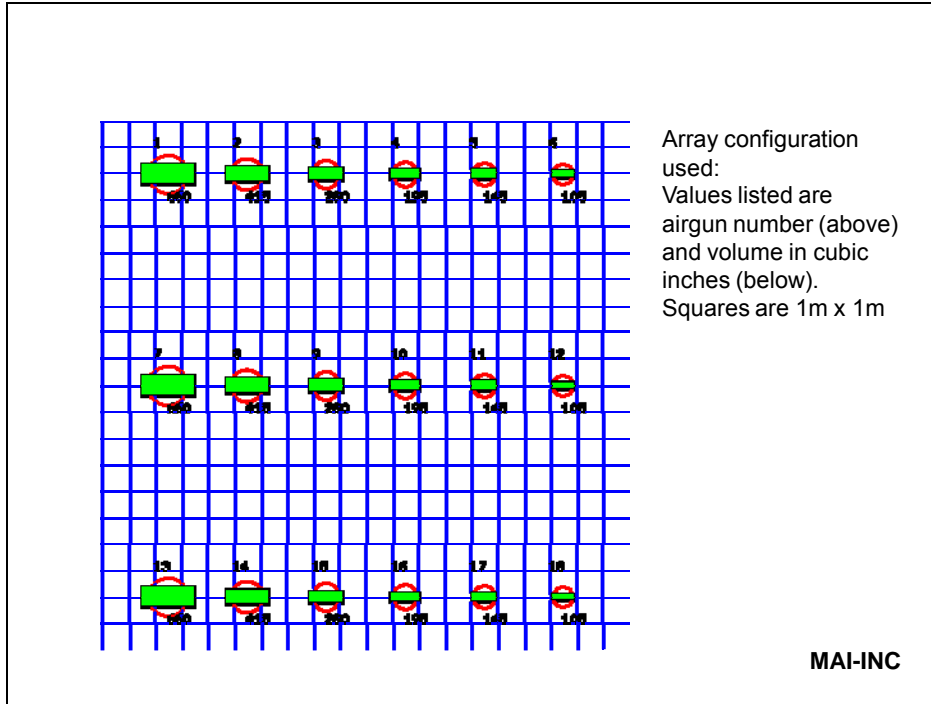

Figure 4. Airgun array configuration used in CASS/GRAB 3-D source directivity vs. frequency comparison to Gundalf source model.

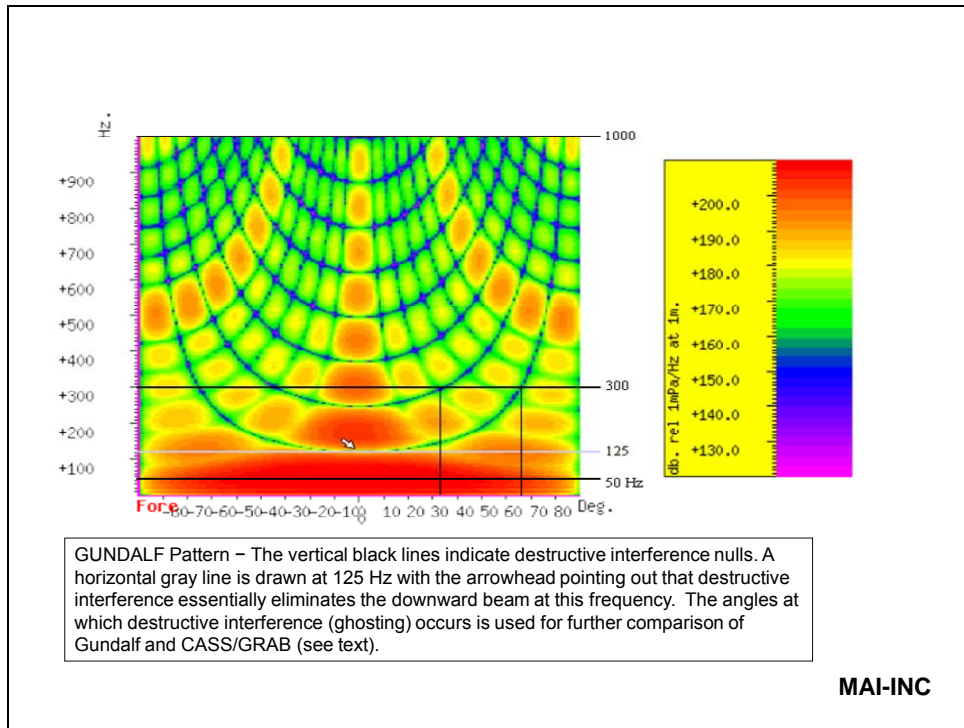

Figure 5. Array directivity (in line) for frequency vs. vertical angle in a 3-D Gundalf model.

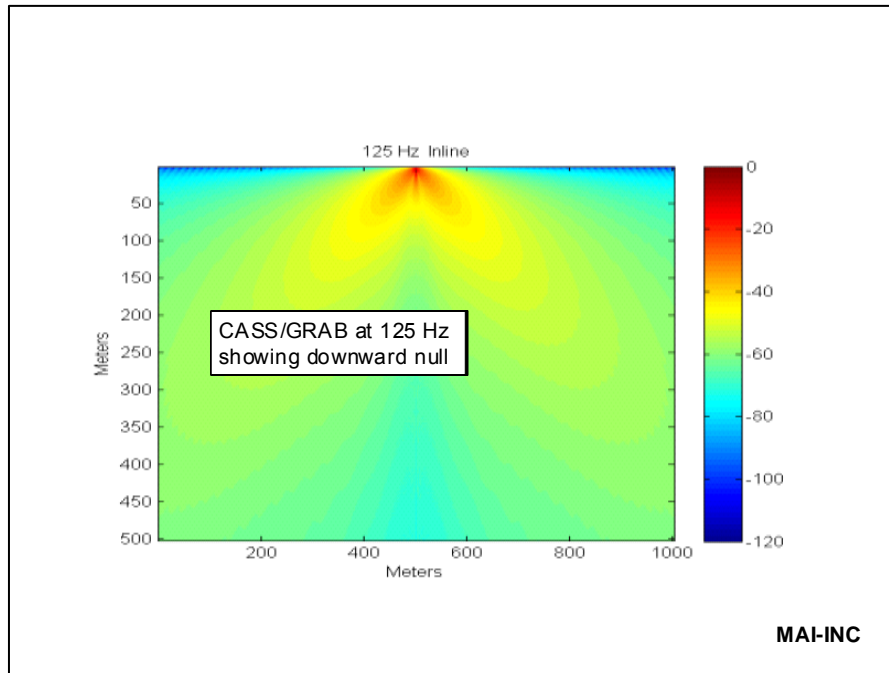

Figure 6. CASS/GRAB model beam patterns at 125 Hz.

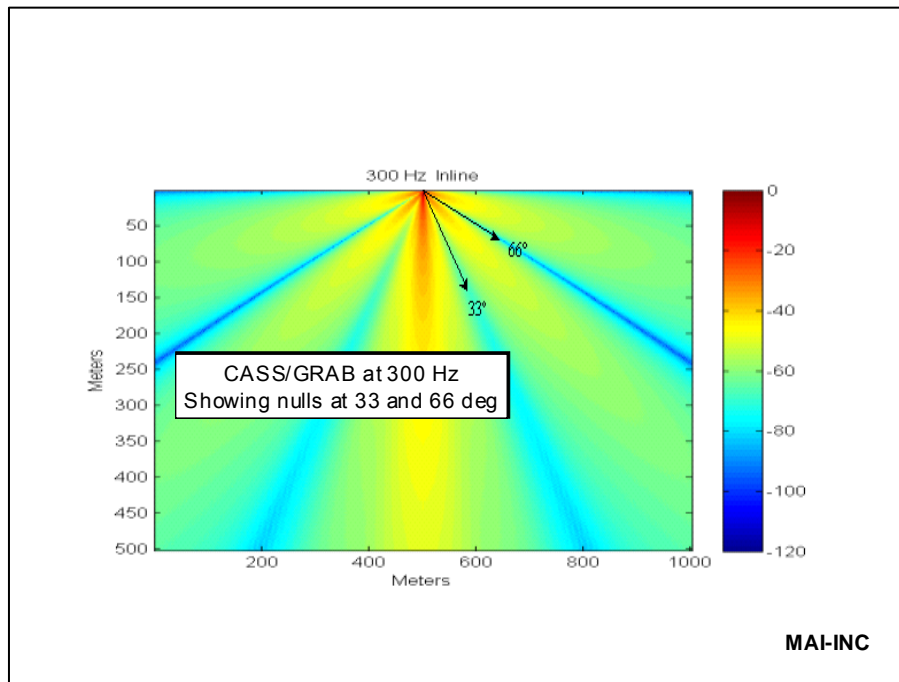

Figure 7. CASS/GRAB model beam patterns at 300 Hz.

Figure 8 provides modelled beam patterns for a ‘simple’ seven element (airgun) array of uniform volume, slightly different than the array configuration shown in Figure 4, i.e., more directive and more side lobes at higher frequency. The key information to glean from this Figure is the strong horizontal beam pattern showing up at 1 kHz, indicating good transmission patterns outwards in range. Compare this to the 50 Hz plot (Figure 8, top left panel) where virtually all of the energy is directed downward.

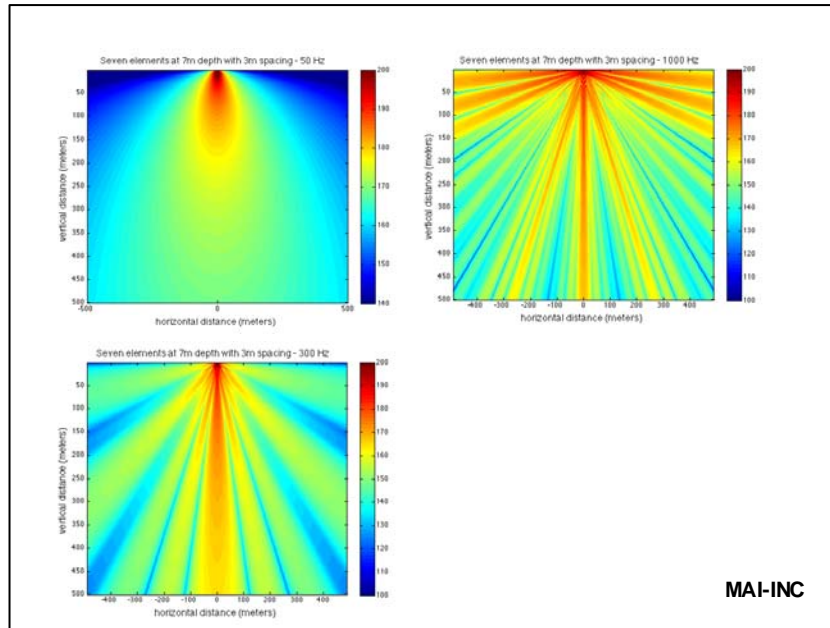

Figure 8. Modelled beam patterns, based on CASS/GRAB, for a simple seven airgun array at 50, 300 and 1000 Hz.

Figure 9 provides insight into the particle velocity field generated by a single source located near (in proportion to the wavelength) the surface, i.e., the physical arrangement most applicable to many seismic airgun activities.

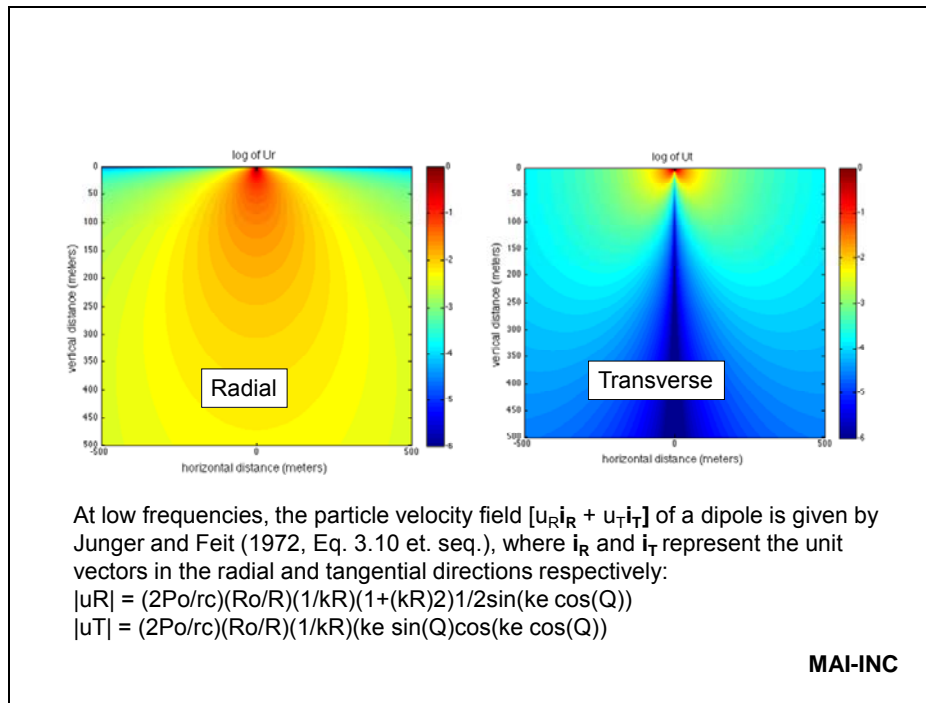

Figure 9. Particle velocity of single element at 50 Hz.

This arrangement can be viewed most simply in the form of a dipole formed by the pressure source and the nearby pressure release surface of the air/water interface. Thus, at low frequencies, the particle velocity field [$u_R i_R + u_T i_T$] of a dipole is given by Junger and Feit (1972, Eq. 3.10 *et seq.*), where i_R and i_T represent the unit vectors in the radial and tangential directions respectively as shown here and in Figure 9.

$$|u_R| = (2P_0/\rho c)(R_0/R)(1/kR)(1+(kR)^2)^{1/2}\sin(ke \cos(\Theta))$$

$$|u_T| = (2P_0/\rho c)(R_0/R)(1/kR)(ke \sin(\Theta)\cos(ke \cos(\Theta)))$$

where

P_0 = SL of the source element in dB//Pref @ 1m

R = Range in m

R_0 = Reference range, 1 m

ρc = characteristic impedance (density \times sound velocity)

k = acoustic wave number ($2\pi f/c$) in m^{-1}

e = source distance below the surface in m

Θ = angle from the vertical measured at the surface directly above the source,
i.e., up $\Rightarrow 0^\circ$, down $\Rightarrow 180^\circ$

Constraints: (ke^2/R) & $(e/r) \ll 1$

The following comparisons are relevant to the results illustrated in Figure 9:

- The u_R plots are minimized along the free surface boundary ($\Theta = \pi/2$) as expected.
- The u_T plots show the velocity gradients maximized along the free surface boundary.
- Along the main downward beam the u_R values closely match the expected plane wave result of $u = p/\rho c$.
- Near the source, the u_R term $[(1/kR)(1+(kR)^2)^{1/2}]$ clearly dominates, and tends to unity at long range as expected. Similarly, the u_T term vanishes as $1/R$ at long ranges, as would be expected.

Figure 10 provides a detailed graphical view of the near field pressure in the immediate vicinity of a line array of sources. The analysis used to create this result is based on a simple superposition of point sources.

The results illustrate the side lobes in the vicinity of the array as well as the coherent development of the main beam as it forms with increasing distance along the main axis of the array. This result is of importance in understanding the reduced strength of the near field relative to the effective far field source level of the array.

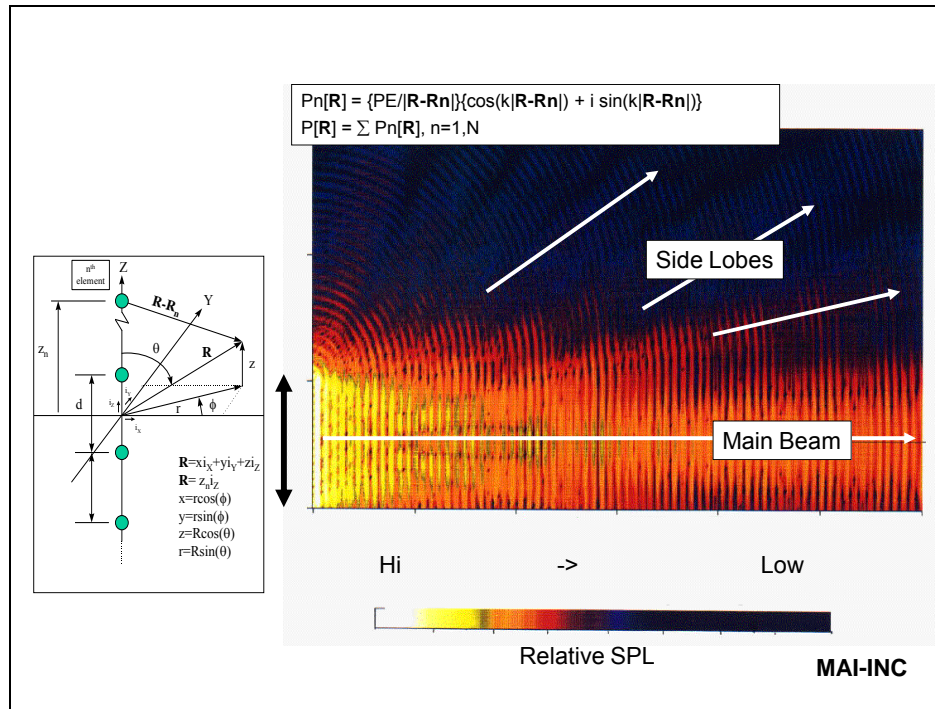

Figure 10. Modelling a simple line array.

Participants' Questions

- Are there cases where two or more different source models have been applied to a particular airgun configuration and the comparative results have been made public? This would, if available, be helpful in obtaining an understanding of the degree of similarity or difference in what is predicted by various source models. It was noted that Natalia Sidorovskaia published research, perhaps in JASA,⁴ on a modelling study of data acquired by the U.S. Navy in the Gulf of Mexico as part of the MMS (Minerals Management Service) SWSS (Sperm Whale Seismic Study) work. She compared predictions from the Gundalf model with empirical data. A related study is ongoing involving comparison of detailed empirical data for an airgun array operating in the Gulf of Mexico vs. Gundalf and Nucleus predictions. Participants also noted that a comparison of output from an earlier version of Gundalf vs. Nucleus revealed many differences in the outputs. The earlier version of the Gundalf model did not treat clusters the same way as Nucleus.
- How accurate are these models in predicting nearfield levels around airgun arrays, and to what degree does their accuracy depend on frequency? It was noted that modelling codes do not deal with high frequencies very well and that, in the very near field, there are non-linear effects that the models do not adequately address. It was also noted that sound levels vary from shot to shot and that the JIP is undertaking an airgun calibration

⁴ See Sidorovskaia et al. (2005).

study to measure source levels on a shot-by-shot basis and at high frequency to update source level modelling codes.

Propagation Modelling—Beaufort Sea Conditions

Dr. Roberto Racca, JASCO (Primary Talk)

This presentation discussed the issues surrounding the modelling of acoustic propagation in the bathymetric and geophysical environments encountered in the Beaufort Sea. To this end, it first reviews the basics of sound propagation modelling in general terms and examines how acoustic models are used for assessment of potential impacts on marine mammals and for mitigation planning. It then gives an introduction to the modelling of seismic array footprints, and lastly examines the important characteristics of the Beaufort Sea environment that affect sound propagation and make the estimation of acoustic levels in this region particularly challenging.

Propagation modelling refers to the use of numerical algorithms to predict how sounds are attenuated as they propagate through the ocean. In essence, it involves taking a source level (SL, expressed in dB re 1 μ Pa at 1 m) and applying to it a predicted transmission loss (TL, expressed in dB) to yield a predicted received level (RL, in dB re 1 μ Pa). The TL parameter depends on the range of propagation and the type of acoustic environment in which the signal propagates, both in the water column itself and in the sea floor which also acts as a transmission medium. Because transmission loss is frequency dependent, the overall attenuation along a particular propagation path will depend on the frequency spectrum of the source, i.e., the amplitude of the signal at specific frequencies. Quite often, when dealing with biological receivers (marine animals), the frequency-dependent sensitivity of the receiver is also built into the equation by adjusting the received levels by some measure of the auditory sensitivity of the animal at individual frequencies. In the context of estimation and mitigation of impacts on marine mammals, models are used to forecast the size of the zones or volumes over which sound levels may exceed specific impact thresholds, e.g., those at which temporary or permanent damage to the animal's hearing might result. For sub-injury assessments, such as the estimation of behavioural response effects, models can provide estimates of the number of individuals that may be exposed to a given sound level and thus potentially affected. By mapping the effect of changes in the acoustic source properties on the extent of the region ensonified above a threshold, models can be used to assess the effectiveness of certain mitigation measures. For the case of a geophysical exploration survey, these measures may include changing the orientation of the seismic lines or the seismic source array to avoid the projecting higher levels of noise toward environmentally critical areas, altering the tow depth of the source or using different configurations of the airguns in the array. Mitigation measures for potentially injurious levels of exposure, which occur relatively close to the location of the source, generally consist in shutting down the operation if an animal is observed within or approaching the boundary of a circular safety zone of specified radius. This radius, which may be subject to validation and refinement through empirical sound level measurements at the start of a survey, is commonly estimated by modelling the irregular acoustic footprint of the array to the prescribed threshold and setting the circular boundary so that it encompasses 95% of the estimated footprint area.

The modelling of sound propagation in the Beaufort Sea is made particularly challenging by the significant variability of acoustically relevant parameters including the vertical sound velocity

profile (SVP) of the water column, the seafloor depth, and the geoacoustic properties of the bottom. Large gradients in bathymetry occur at the edge of the continental shelf, leading to abrupt changes in the propagation conditions there. The scenario is further complicated by the strong geographic variability of the geoacoustic properties due to lithologic zonation and localized regions of permafrost. These factors lead to a highly non-uniform acoustic environment. As a result, estimated sound propagation footprints to given threshold levels can be very different, depending on the areas where surveys are to be conducted. From an operational standpoint, a single survey line may span regions with widely different propagation properties, requiring adaptive adjustment of safety radii based on pre-computed estimates of safety radii from modelling.

Participants' Questions

- *In response to a question about the nature of the JASCO propagation model, Dr. Racca explained that it is a combination of two things.* The first is a source model that has array modelling code developed by JASCO and verified in a number of conditions against some industry standards (primarily corresponding results from Nucleus software). This model generates the equivalent of a directional point source and predicts levels in terms of frequency and angle. Secondly, these predicted direction- and frequency-dependent source levels are injected into a propagation model, which is a parabolic equation code similar to RAM but takes into account loss due to transfer of energy into shear waves into the sea floor (something that the earlier version of RAM did not do). This code is normally run for frequencies that range from a minimum of 5-10 Hz to a maximum of 1-2 kHz. The model uses sound speed protocols most appropriate to the location and season in which the seismic survey will be conducted. Then JASCO tries to obtain the most accurate possible classification of likely sea floor properties based on core drilling and geoacoustic studies. JASCO generally looks at properties down to a few hundred metres below the seafloor to take into account potential propagation into deep strata.
- *What are the effects of influx of fresh water during spring melt on propagation modelling?* The major effect would be on the salinity profile; salinity would decrease in the near-surface portion of the water column. The JASCO model does not specifically take into account spring melt, but it does utilize the anticipated sound speed profile.
- *What about sound propagation under ice?* The model does not specifically address propagation under ice because seismic surveys are not typically conducted in these conditions. It was noted that JASCO had done studies for one client in which the model allowed for a layer of ice.

Impact Radii and CSEL

David E. Hannay, JASCO (Primary Talk)

A recent report (Southall et al. 2007) has recommended use of CSEL for estimating TTS and permanent threshold shift (PTS) effects on marine mammals exposed to impulsive sounds such as seismic pulses. This presentation (see Appendix E, p. E-92 to E-98) introduced the concepts of TTS and PTS and then discussed how the CSEL metric is computed from standard seismic pressure measurements. The discussion described the approach used to incorporate frequency-

dependent weighting appropriate for different marine mammal species groups (M-weighting). It presented CSEL values and compared them to root-mean-square (rms) values for several recent seismic surveys.

Participants' Questions

The JASCO recorders were placed on the seabed—how would the results differ if recorders were at different depths? The receivers were at 40 m depth. That was appropriate because close-to-maximum sound levels occurred near the bottom, whereas sound levels at the surface were near zero.

Calculating CSEL: A Virtual Example Using AIM
 Dr. William T. Ellison, Marine Acoustics Inc. (Follow-up Talk)

The objective of this follow-up presentation was to provide a simple but detailed example of CSEL calculations for animals exposed to a series of short pulses, each of equal duration and from a source operating at constant source level (SL). The elements of this example are illustrated in Figure 11.

The basic concepts of the Acoustic Integration Model © (AIM) are illustrated in Figure 12. The model calculates and integrates the various features shown in Figure 11. This includes determining the 3-D movement over time of the various animals and sound sources, and calculating the point to point transmission loss (see Step#4) to each animal location for each sound produced by the source.

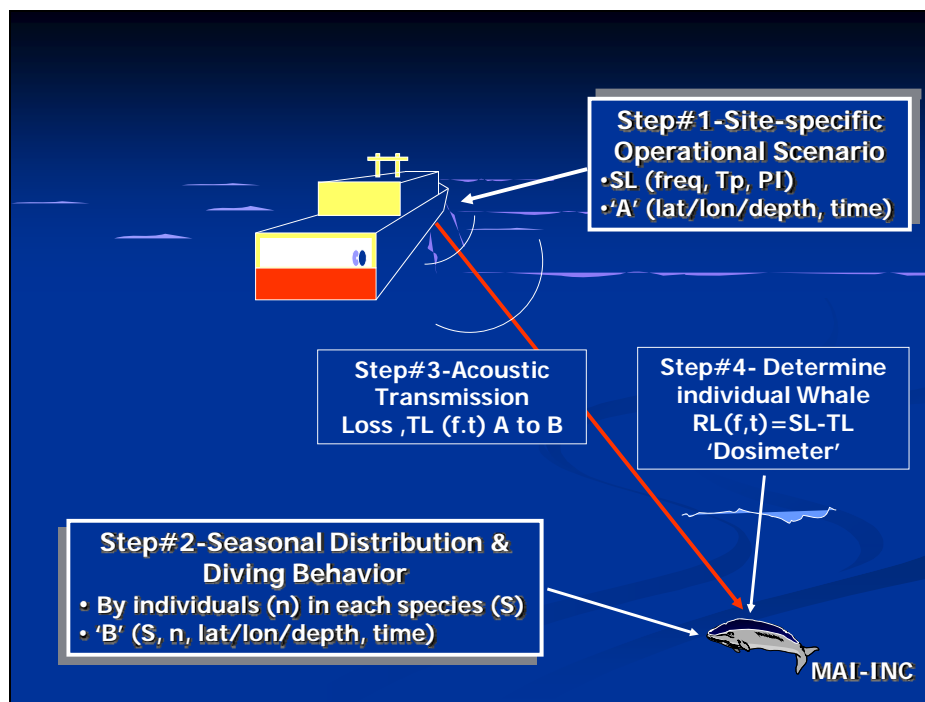

Figure 11. The key elements affecting a whale's cumulative sound exposure from a source of anthropogenic sound.

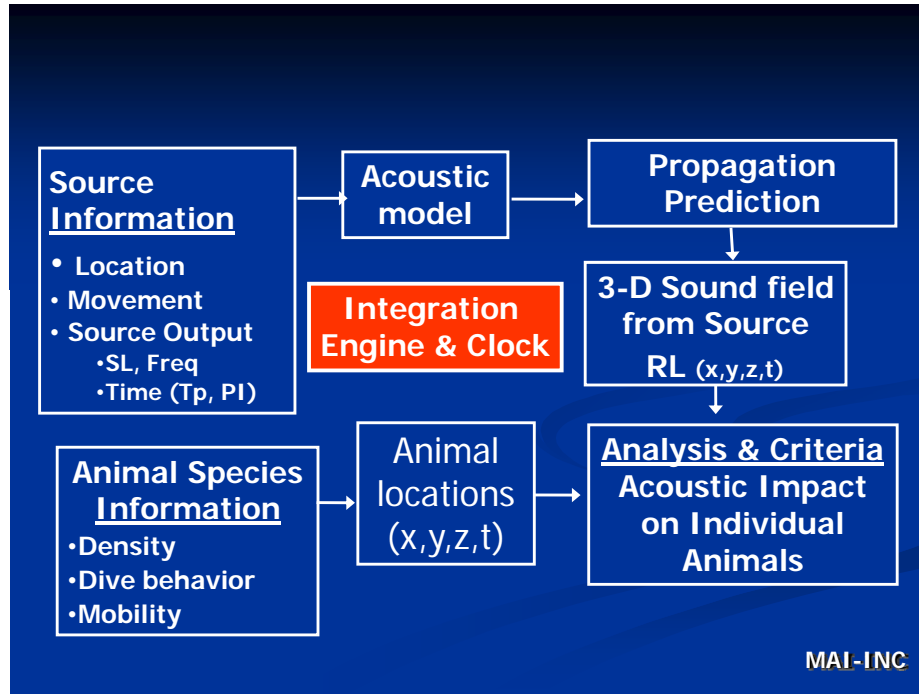

Figure 12. Basic concept of AIM: block diagram of components and data flow.

Figure 13 is a screen shot showing a typical AIM output window. The individual graphics screens provide a visual representation of the major features of the model. The chart at the upper right (Gulf of Mexico) shows the location of a number of whales distributed near the continental shelf.

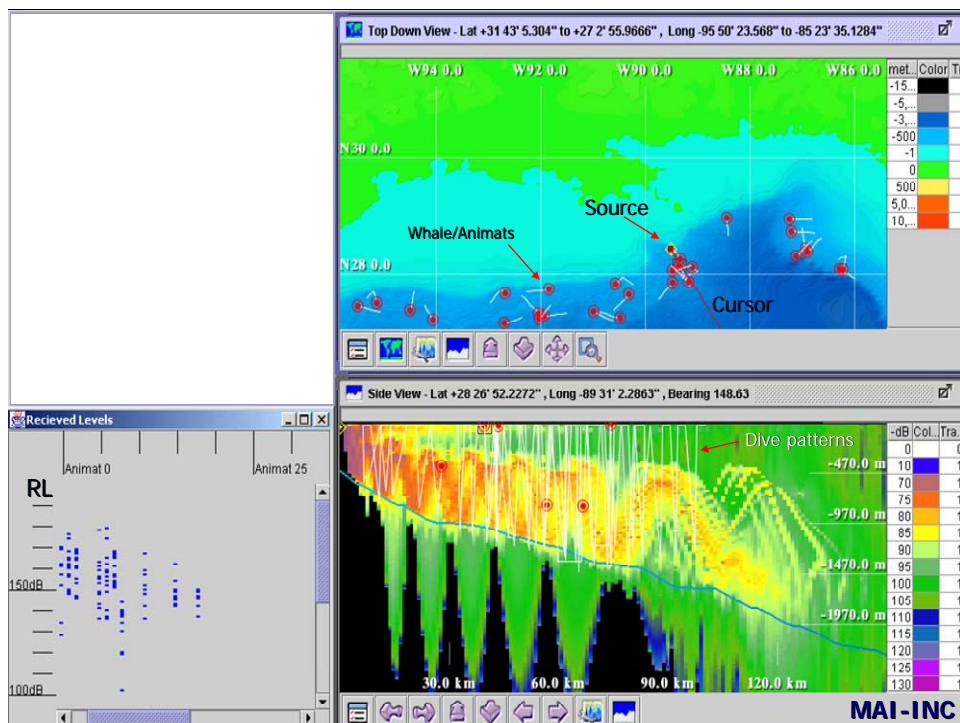

Figure 13. AIM model output and interpretation.

The lower right window in Figure 13 shows the propagation path (range and depth) from the source shown in the upper right panel. The graph in the lower left provides a ready reference for the history of sound exposure realized by each of the whales in the simulation.

Figure 14 provides an example of calculating CSEL based on the received levels calculated for animat #11 from the simulation illustrated in Figure 13.

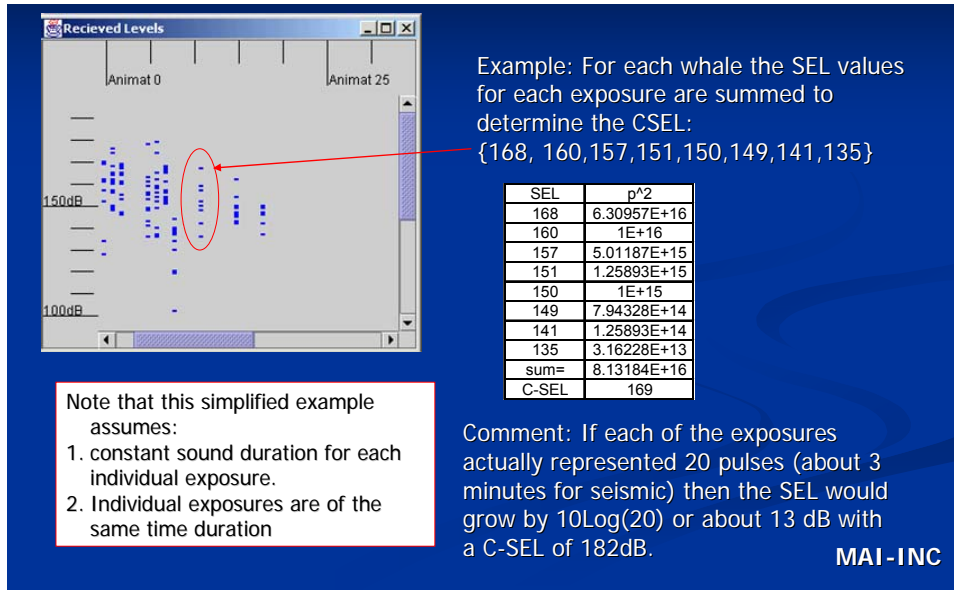

Figure 14. Determining CSEL.

Participants' Questions

- *In the AIM model, when is it appropriate to stop the accumulation of sound energy for the calculation of CSEL and reset the accumulated value to zero?* It was noted that one proposal is for the cumulation to be started and stopped every 24 hours. However, this really is an open question. One participant thought that the regulators should provide guidance on this issue.

Empirical Measurements of Airgun Sounds

Empirical Measurements – Canadian Beaufort

David E. Hannay, JASCO (Primary Talk)

Seismic sound propagation depends on the ocean environment in which the sound propagates. The speed of sound in the ocean varies with water temperature, salinity, and depth below surface. Gradients in temperature and salinity can lead to variations of sound speed that would not occur in a homogeneous ocean. When strong variations exist, sound is refracted and travels along curved paths. Sound can be refracted downward into the seabed, where it is often more strongly absorbed, or to the sea surface where it is strongly reflected back down into the ocean. Sounds can even be trapped within finite depth intervals, leading to long-range propagation with very little energy loss. The depth of the water and type of ocean bottom are also important factors that influence how well sound propagates. Much of the Beaufort Sea shelf has water depths less than 100 m and in some

areas the bottoms are good at reflecting seismic sound energy back up into the ocean. These shallow conditions can lead to enhanced sound propagation conditions where higher sound levels occur than in deeper waters. This presentation (see Appendix E, p. E-104 to E-112) provides the results of measurements of seismic sounds in the ocean and shows how sound levels have varied with distance away from seismic sources operated in water depths between 10 m and 160 m.

***Empirical Measurements of Airgun Sounds, Canadian Beaufort Sea:
Early Greeneridge Measurements***

Dr. W. John Richardson, LGL (Follow-up Talk)

⁵ During the summer open-water seasons of 1980–1984, Dr. Charles Greene measured sounds from airgun arrays and various other sources then in use for marine seismic exploration in the southeastern Beaufort Sea. This was part of a broader study of underwater sounds created by oil industry activities, and the effects of these sounds on behaviour of bowhead whales. That study was funded by the U.S. Bureau of Land Management and Minerals Management Service, and was conducted by LGL Ltd. and Greeneridge Sciences Inc. The data on characteristics and propagation of underwater sounds from airgun arrays and other seismic sources were published by Greene and Richardson (1988), with additional details in a technical report by Greene (1985) and in annual reports cited there. This was one of the first extensive studies of the characteristics and propagation of airgun and related seismic sounds to in-water receivers at medium and long horizontal distances (100s of metres to almost 100 km). This study was among the first to document several of the now widely-known characteristics of marine seismic signals in shallow-water areas, including the following:

- Airgun pulses are dominated by low frequency energy (<150 Hz) but include diminishing amounts of energy at progressively higher frequencies up to at least several hundred hertz;
- Airgun pulses exhibit dispersive propagation as they move away from the source, with pulse duration tending to increase from 10s to 100s of milliseconds at increasing distances;
- At longer distances, the higher-frequency components tend to arrive a fraction of a second before the lower-frequency components, resulting in a downward “chirp” effect.
- In some locations, there is an initial brief arrival of very low frequency bottom-borne energy prior to the onset of the downward-sweeping “chirp”.
- Received levels of pulses from a specific airgun array are quite variable even at a single distance. However, in the southeastern Beaufort Sea, the received level at 1.9 km range can be as much as 179 dB re 1 μ Pa (on an approximate rms-over-pulse-duration basis), and at times the sound pulses from an airgun array are detectable ≥ 73 km from the source.
- Received levels of sound pulses from an airgun array were, at a given distance, considerably higher than levels of other industry sources, although the latter were generally continuous whereas airgun pulses are intermittent.
- Depth in the water column affects the levels of sound pulses from distant airgun arrays, with the level tending to diminish as the receiver approaches the surface.

⁵ No PowerPoint presentation was given during this talk.

Participants' Questions

- *At what degrees perpendicular to the source do you define “broadside”?* It was noted that there is no set way or scientific basis for this. Typically, JASCO examines five points around the peak of the pulse lobe. One participant noted that defining the broadside aspect should be standardized.
- *What is the sampling rate for the JASCO studies?* JASCO noted that they typically sample at 48 kHz.
- *Do safety radii consider spatial components of the animals, i.e., will a marine mammal actually occur at a given water depth?* It was noted that in deep water, animals may not dive to bottom. Sperm whales can reach maximum depths of around 2 km and beaked whales slightly shallower depths. It would not be relevant to consider greater depths when assessing how far away from the source a given received level, e.g., 160 dB re 1 μ Pa (rms), could occur. Although these examples are not directly relevant to the Beaufort Sea, they do indicate that criteria should take account of the potential dive depths of the animals occurring in a given area.

Variability of Seismic Sounds Recorded in the Alaskan Beaufort Sea

Dr. William C. Burgess, Greeneridge Sciences (Primary Talk)

Assessment and regulation of seismic sound production typically depend on models of received level versus distance. These theoretical and empirical models provide general guidance, but rarely convey the degree of variability of sound signatures and received levels present *in situ*. Understanding this variability is essential when estimating model error and interpreting potentially associated animal behaviour.

Variability in received sound takes two forms: (1) variability in the time-frequency signatures of seismic pulses and (2) variability in received level associated with changing propagation conditions or aspect dependence of the source’s radiation pattern. The Beaufort Sea poses a particular challenge with regard to the latter because of its significant bathymetric and geoacoustic variability in regions of seismic interest. Seismic operations take place both inshore and offshore of barrier islands, in bays and river deltas, and over seabed types ranging from soft mud to hard permafrost.

Greeneridge Sciences has conducted several studies of seismic survey sounds in the Canadian and Alaskan Beaufort Sea since 1980. One study in particular, conducted on behalf of Western Geophysical in 1998 and 1999, focused on sounds from a 1,210-in³ airgun array towed over ocean-bottom cables (OBC) which contained hydrophones. All examples discussed here were drawn from this study.

The most common source of signature variability is the “waveguide cutoff”, a tendency of signal content below a certain frequency to attenuate rapidly. The water depth along a signal’s propagation path determines the cutoff frequency: the shallower the water, the higher the cutoff.

As the seismic vessel moves, propagation paths may change such that the cutoff frequency observed at a receiver increases or decreases with time. A spectacular example of this can be

seen in downslope propagation data from a 12-km seismic transect starting from inshore waters, crossing a bar, and proceeding into deeper offshore waters. As the seismic vessel progressed offshore towards the recording station, the lowest observed frequency of the received seismic pulses decreased from about 300 Hz inshore of the bar (5 m depth) to 10 Hz near the recording station (23 m depth).

At frequencies just above the waveguide cutoff, sounds propagate more slowly than at higher frequencies. This phenomenon, known as “geometric dispersion”, gradually modifies seismic pulses from clicks and pops when received at short ranges to downswept whistles when received at long ranges.

Another source of signature variability results from propagation through the sub-bottom. These signals tend to be at very low frequencies – below a few tens of hertz – and to arrive earlier than the water-borne portion of the seismic pulse. At longer ranges or when barrier islands block the water-borne pulse, the seismic signature may consist only of the sub-bottom wave.

Besides variability in the time-frequency signature of seismic pulses, variability in overall received levels is also common in the Western Geophysical data. One surprising example involves a profound 15-20 dB bow-stern aspect dependence observed in shallow (8 m) water that was absent in deep (23 m) water. Our hypothesis is that bubbles generated by the airgun array interfered with horizontal propagation when the array physically occupied much of the available water depth.

Changes in the geoacoustics of the propagation path can strongly affect received levels. The Beaufort Sea presents a particular challenge in this respect because of the abundant patches of relic subsea permafrost. Modelling done during the Western Geophysical study suggested that received levels of seismic shots that happened to be fired over relic permafrost could increase by 20 dB even at ranges in the low tens of kilometres. Permafrost patchiness could contribute not only to variability in received levels with time, as the seismic vessel moves over the patches, but also increased aspect dependence. OBC data obtained during the Western Geophysical study were consistent with this hypothesis, showing increased non-uniformity in the seismic source’s horizontal radiation pattern in a region believed to have relic permafrost.

Because of the variability of received levels and signatures with location in the Beaufort Sea, it is important to ask to what extent sound-source-verification (SSV) measurements of one survey configuration can be compared with those of another when the measurements are made at different sites. From a regulatory perspective relative comparisons are of great value; it is helpful to be able to say that one seismic source configuration is no stronger than another, or if it is, it is stronger by so much. However, the practice of conducting SSV tests at sites of opportunity when Beaufort Sea propagation conditions are so variable makes such relative comparisons difficult.

One approach to addressing the relative comparison issue is to establish “reference tracks” in the Beaufort Sea where SSV measurements would preferentially be made. Characterizing seismic sources in the same location would lend confidence to relative comparisons. This approach was used during the Western Geophysical study, where two reference tracks were chosen – one

inshore and one offshore – and all vessel-noise and seismic-pulse measurements were made with the sources following those reference tracks.

Participants' Questions

- *Relic permafrost is a special case of a different substrate, correct?* Dr. Burgess replied that it was his understanding that sound speed in permafrost would be faster than other substrates.
- *How did you know that there was relic permafrost in your study area?* Dr. Burgess noted that the information was gathered from a published paper.

Sound Source Verification: Procedural Issues in the Field and During Analysis

Dr. Susanna B. Blackwell, Greeneridge Sciences (Primary Talk)

Five procedural issues during fieldwork were discussed in some detail (see Appendix E, p. E-124 to E-146). These included (1) what maximum range (distance between recorders and seismic vessel) should be used to ensure that data are collected to the received level of interest; (2) the aspect dependence of the measurements, i.e., the fact that it is important to make measurements both in line with the ship (bow or stern aspect) and broadside to the ship; (3) the optimum source track that will yield the desired data (i.e., endfire and broadside data at a range of distances), while requiring the least travel by the seismic vessel; (4) how the recorder deployment may have to be modified as a function of water depth; and (5) how the sampling frequency to be used depends on the question asked, i.e., what type of animals are of concern. Five procedural issues that are encountered during analysis of the data were also discussed; these included (1) discrepancies that are often found between a quick-look field report and the final report; (2) what pulse analysis method to use; (3) curve-fitting issues, i.e., whether to report the best fit (median) or 95th percentile fit; (4) what frequency weighting scheme to apply to the data; and (5) the relationship between sound pressure level and sound exposure level as a function of distance from the seismic vessel.

Procedural Issues in the Field and During Analysis

Dr. John Diebold, L-DEO (Follow-up Talk)

This presentation⁶ examined the experimental design (cruise track) for R.V. *Langseth's* source array calibration in 2007–2008. The purpose of the design was to concentrate the measurements on fore-aft and athwartships aspect angles. In this way, directivity (if any) will be maximally revealed. This design requires a moored receiver. The spiral (see Figure 15) is designed to provide a constant ratio of distance along track and change in radial offset. This approach worked well for sound source verification measurements at L-DEO's shallow-water site (Tolstoy et al. 2009).

⁶ No PowerPoint presentation was given during this talk.

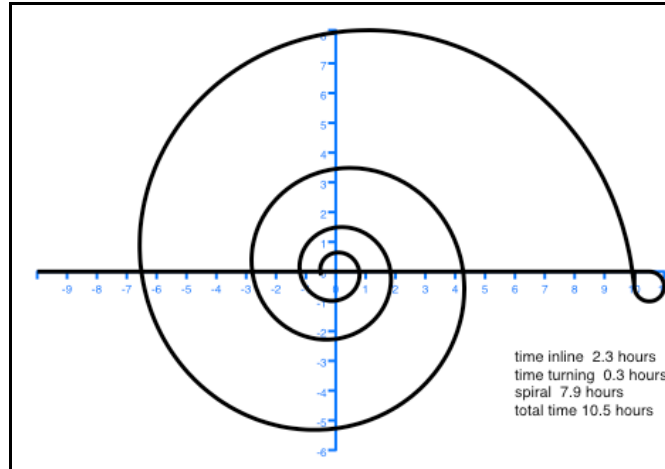

Figure 15. Experimental design (cruise track) for the L-DEO source array calibration.

Participants' Questions

- *If you could moor the receiving buoy, would this be a useful way to get broadside-aspect data at many distances?* Dr. Diebold replied that it was not a useful way because the broadside angle is not quite 90 degrees when using their approach. However, a participant noted that the spiral approach has the advantage of getting more sampled distances.
- *If you acquire one strange data point, is it common practice to discard it?* Dr. Diebold noted that if you cannot figure out what happened, for example, if there was no evidence of a recording instrument error or the airguns going out of spec, you would keep that data point.

Modelling and Empirical Comparisons

Model-Data Comparison

David E. Hannay, JASCO (Primary Talk)

Acoustic models have been used to estimate airgun sound levels vs. distance for planned seismic surveys in the Beaufort Sea. These models are often used to predict the areas ensonified above thresholds that represent impact levels to marine mammals. The predicted areas are then used in estimating numbers of animals that might be impacted and for determining initial exclusion zone radii that are to be monitored by marine mammal observers and subject to mitigation measures. This presentation (see Appendix E, p. E-147 to E-153) provides a comparison of pre-season model results with in-field measurements and summarizes the strengths and weaknesses of the model approach for predicting the different sound metrics commonly applied for impact assessments.

Pre-Season Modelling – Empirical Comparisons, Sakhalin Experiences

Michael R. Jenkerson, ExxonMobil (Follow-up Talk)

This presentation provides an example from the Odoptu seismic survey off Sakhalin Island in the Russian Far East⁷ [For more details, see the open-access paper by Rutenko et al. (2007).] Based on literature estimates, it was expected that the gray whales of concern would respond to sounds above ~163 dB re 1 μ Pa (rms). It was initially estimated that a 4 km buffer zone from the full operating airgun array would be needed to avoid exposure to ≥ 163 dB. Two in-field calibration experiments were conducted where sonobuoy receivers were placed on the seafloor and the seismic vessel with operating airguns sailed towards the receivers as well as broadside to the receivers. Results showed that a 7 km buffer zone would actually be required when the source was broadside to the receivers, indicating that the airgun array produced stronger than expected crossline sound. Ultimately, the airgun array size had to be halved to maintain the 4 km buffer zone. However, reducing the array size can sometimes result in data quality issues for the seismic survey. Since results showed that crossline and inline received levels were different than anticipated, the 3-D source characterization study being undertaken by the JIP will be valuable for future calibrations.

Seismic Sound Modelling Verification Against ENL 2001 Measurements

Dr. Roberto Racca, JASCO (Follow-up Talk)

This presentation describes the measurement layout used in 2001 to monitor the sound levels from a dedicated test line shot before the start of a seismic survey conducted by Exxon Neftegaz Limited (ENL) off the northeastern shore of Sakhalin Island in the Russian Far East. It then outlines the parameters used in the numerical modelling of the source and of the propagation environment and, lastly, compares graphically the measured and modelled levels at six bottom mounted recording stations for numerous source locations (shot points) along the test track. The comparison is only approximate in that the measurement and the modelling as performed yielded different per-pulse metrics: 90% energy rms SPL for the former and SEL for the latter. Taking into account the typical relation between these quantities for seismic pulses at a range of a few km, however, the model results are generally seen to track closely the trend of the measurements with range and indeed to tend toward over-estimation – thus providing precautionary values if used in impact assessment.

Participants' Questions

- *JASCO models seemed to under-predict measured sound levels in shallow water—what is the current understanding of that?* JASCO noted that this is a difficult question to answer. Ultimately, good geoacoustics data are required for accurate modelling results.
- *On average, models predict the shape of the received level vs. range curve quite well. However, have you come to any conclusions as to why there seems to be a difference of about 3 dB between predicted and measured sound levels in shallow waters over a*

⁷ This summary was prepared by LGL from notes and audio recordings and later reviewed by M. Jenkerson.

number of different JASCO studies? It was noted that there are uncertainties and errors in both modelling and field measurements. Also, it is often not possible to know (when pre-season modelling is done) exactly where the field measurements will be taken. A participant noted that this is a good reason to re-do modelling after the field measurements are acquired so as to allow (in the model) for the exact circumstances where field measurements were taken.

- *Do empirical results feed back into JASCO acoustic models to improve them?* Mr. Hannay noted that JASCO has used previous year's data, for example, bottom inversions for subsequent analyses. It was later confirmed that the algorithms of the model do not change, only the inputs for environmental conditions change.

Underwater Sound from On-Ice Vibroseis

There were no formal presentations on the topic of on-ice Vibroseis. There was a limited discussion of the topic among workshop participants. The group noted that there have been at least two empirical studies of underwater sound from on-ice Vibroseis. One of these studies was proprietary, and it was unclear whether the results of the second study are publically available. Two publically available reports (Cummings et al. 1981; Holliday et al. 1984) contain some limited sound measurements of Vibroseis from the Prudhoe Bay area of the Alaskan Beaufort Sea.

A participant asked what the environmental concerns were in the case of Vibroseis. It was noted that there are two main concerns: the effects of noise and ice vibrations on ringed seals (*Pusa hispida*) and polar bears (*Ursus maritimus*). Vibroseis occurs in areas of relatively smooth fast ice during the mid- and late-winter periods. This activity overlaps spatially and temporally with ringed seals, including periods when seals haul out on top of the ice in snow-covered lairs. There is concern about the effects of underwater noise and ice vibration from Vibroseis, primarily on seal behaviour. There is also concern about the effects of in-air noise and ice vibration on denning polar bears. Workshop participants agreed that if there is a need for information on sounds from on-ice Vibroseis, the best initial approach to the topic would be to obtain access to unpublished results.

Workshop Day Two

Workshop participants were given a list of over 70 data gaps and procedural issues that had been identified during Day One of the workshop (Appendix D). An extended discussion ensued to augment, clarify, and prioritize the data gaps. The intent was to narrow down the list to three data gaps that would be discussed in breakout groups, which were to outline follow up studies suitable for meeting the ESRF objectives. As a first step towards identifying the three most important and relevant data gaps, the workshop participants (through discussions) narrowed down the long list identified on Day One to a short list of eight data gaps and procedural issues. This list is provided below and organized by workshop topic. The group subsequently voted on what they deemed to be the three most important and relevant data gaps and procedural issues.

Top Eight Data Gaps and Procedural Issues

Sound Metrics: Relevant to Airgun Sounds

1. There is a need for better sharing of information about sound metrics relevant to airgun pulses and marine mammals, and related mitigation measures (i.e., safety zones), between industry organizations, regulators, and media representatives to minimize misunderstandings about key issues. Participants discussed the feasibility of a project that would provide the regulatory community, stakeholders and the media with instructional materials concerning geophysical surveys, underwater sound and associated metrics, and marine mammals.

Modelling of Predicted Airgun Sound Levels

Source Models for Airgun Arrays

2. How closely do outputs from different airgun array source models (e.g., Gundalf, Nucleus, JASCO's AASM) compare with one another (as a function of frequency and angle), and with available empirical data? In addition, some participants questioned the accuracy of nearfield sound estimates provided by airgun array source models, and the confidence that could be given to source level calculations.

Propagation Modelling in Beaufort Sea Conditions

3. A key data gap for propagation modelling in the Beaufort Sea is the limited available data on geoacoustic properties of the bottom and, to a lesser degree, the limited availability of accurate bathymetric data and sound velocity profiles (SVP). It was noted that available bathymetry and SVP data do not provide good spatial coverage of the Beaufort Sea, particularly in deeper offshore areas. Also, information on relic permafrost (distribution and properties) is considered scarce and workshop participants thought a compilation and statistical characterization of existing data could be useful. Participants also noted that a compilation of data on old river channels may be helpful because these channels are thought to affect sound propagation. It was acknowledged that data on seafloor and sub-bottom conditions are key components of sound propagation, and that high-resolution bottom data, especially those acquired at high frequency, would be very useful for propagation models. A second component of this data gap related to prioritizing the most important data inputs that influence propagation model results. Participants noted that the JIP is conducting a modelling sensitivity study to review the sensitivities to model parameters.

Impact Radii and CSEL Approaches

4. Workshop participants noted that widely varying mitigation approaches, monitoring requirements, and impact criteria are applied and/or recommended in different jurisdictions. Participants acknowledged that there is a need to take a broad look at the approaches currently applied in the Canadian Beaufort Sea in comparison to those used

elsewhere. Some questions to consider include the following: Is M-weighting appropriate? How should one translate an irregular acoustic footprint of an airgun pulse to a single impact radius?

5. When estimating CSEL, an appropriate and justifiable “reset” criterion (or decay constant) for accumulation of airgun pulse exposures has not been defined. Workshop participants discussed and questioned the appropriate interval or decay rate, but concluded that this was a biological question, probably beyond the scope of the ESRF objectives. Another gap identified under this topic was how background sound levels contribute to CSEL.

Empirical Measurements of Airgun Sounds

Canadian and Alaskan Beaufort Sea

6. There is a need to understand differences in shallow vs. deep water propagation and received sound levels in the Canadian Beaufort Sea. Workshop participants suggested the repeated use of selected reference tracks to obtain comparable data on the effect of different airgun sources, source depths, aspects, and upslope vs. downslope propagation of sound. A suitable approach would be to undertake a desktop study to identify candidate reference tracks and then to conduct a field study.

Procedural Issues in Field and in Analysis

7. Several techniques have been used to measure and analyse received levels of airgun pulses. It was recommended that a paper should be prepared on selected aspects of standardized field procedures and analytical approaches for measuring and estimating received levels of airgun sounds.

Modelling and Empirical Comparisons

8. Workshop participants noted the lack of comparative studies of propagation modelling results with empirical measurements. They suggested that researchers should characterize the distribution of differences between propagation modelling results vs. field measurements, and use these results to assess whether or not an offset of some magnitude should be applied to the model output. Participants noted the importance of ensuring that modelling depths (and other assumptions) correspond to the circumstances of the actual SSV measurements.

Key Data Gaps/Procedural Issues and Recommended Studies

As mentioned earlier, the top eight data gaps and procedural issues were voted upon by workshop participants in order to narrow the list down to the three most important and relevant data gaps and procedural issues. In prioritizing and selecting those three cases, workshop participants were

instructed to allow for the ESRF approach and funding realities. More specifically, ESRF studies should complement (and not repeat) other ongoing work (e.g., JIP studies), emphasize syntheses, and be practical, i.e., avoid expensive or very lengthy projects. After selection of the top three data gaps and procedural issues, workshop participants were divided into three breakout groups whose objective was to briefly describe the recommended studies. Based on guidance from the ESRF representatives, recommended studies were to include specific details of the concern, relevance to regulatory issues in the Canadian Beaufort Sea, suggested approach to resolve the concern, and expected outcome if that approach were applied. Breakout groups were also asked to provide an estimated cost of the study. The rapporteur for each breakout group presented the findings of their group at a concluding plenary session involving all participants. Key elements of the three recommended studies are provided below, as summarized by the three breakout groups.

Sound Metrics: Relevant to Airgun Sounds

Rapporteur: Dr. Bill Streever (BP)

Data Gap/Procedural Issue.—Workshop participants felt that there was a need for better sharing of information about sound metrics relevant to airgun pulses and marine mammals, and related mitigation measures (i.e., safety zones), between industry organizations, regulators, and media representatives to minimize misunderstandings about key issues.

Details of the Concern.—Recognizing that some regulators, industry representatives, media representatives, and other stakeholders do not have a firm grasp of issues related to potential impacts of underwater sounds associated with geophysical surveys, this recommended study will provide relevant information on geophysical surveys, underwater sound, and marine mammals in an easily understood instructional package. The primary product will be a computer based instructional package with capacity for user interaction.

Relevance to Regulatory Issues.—Well-informed regulators, industry representatives, media representatives, and other stakeholders will interact more effectively through the regulatory process.

Suggested Approach.—Seek out a contractor or contractor team that can provide experts in marine mammal biology, underwater acoustics, and construction of educational modules. The contract should require multilingual capabilities, including French, English, and First Nations languages. The contractor should have a demonstrated ability to build educational modules. The contractor should also have the ability to draw from existing material, including, for example, material presented on the University of Rhode Island’s DOSITS website, the Cornell University Bioacoustic Research Program’s website, the International Association of Geophysical Contractors’ (IAGC) geophysical exploration video, and others. The contractor should have a multidimensional review process that includes viewpoints from regulators and other stakeholders throughout the development and finalization of the project.

Potential content of the educational modules could include the following:

- An overview of how seismic surveys work. It was noted that the IAGC had produced a video on geophysical surveys that could be used in this project.

- A description of marine mammals of the Canadian Beaufort Sea and their respective hearing abilities.
- A tutorial on underwater sound, including the decibel scale, frequencies, propagation, computation of source levels (i.e., using far field measurements to back calculate a point source), and complications in estimating and using source levels.
- Potential impacts of seismic survey sound including hearing impairment (TTS, PTS), physical harm (tissue trauma), masking, and behavioural changes. It was recommended that examples of behavioural impacts should be provided along with a discussion of biological significance, and impacts on harvesting activities.
- A review of mitigation measures and monitoring techniques including source minimization/optimization, timing of surveys, avoidance of critical areas, use of MMOs, use of PAM, ramp up, and shut downs/power downs for marine mammals within a defined safety zone.
- An overview of the uncertainties and current and planned research.

The members of this breakout group also noted the following:

- The product should be updatable and suitable as entry-point information for reporters, with potential follow up that would include inviting reporters into the field.
- A well designed product could be modified to be used in other parts of the world and linked to or used by educational institutions. Also, the product might become a standard part of marine mammal training and/or required training for seismic crews and could be used in community meetings.
- Training materials should include quiz questions, an evaluation of effectiveness, video clips, and have the capacity for e-discussion groups.
- There should be clear accountability of ownership to ensure maintenance and promote use. It was questioned whether the ESRF would be the owner.

Expected Outcome and Estimated Cost.—The primary product will be a computer-based instructional package with modules on geophysical surveys, underwater sound, marine mammal biology, potential impacts, mitigation and monitoring. The instructional package, if properly designed and distributed, will result in better-informed participants in the regulatory process, who would then operate from a common knowledge base. A very approximate cost estimate of \$100,000+ was provided by the breakout group. It was noted that an appropriately designed product would likely attract collaborative funding from industry and others.

Propagation Modelling in Beaufort Sea Conditions

Rapporteur: David Hannay (JASCO)

Data Gap/Procedural Issue.—The scarcity of data on geoacoustic properties of the seafloor, along with incomplete data on water depths and sound velocity profiles in the Beaufort Sea, were selected as a key data gap that limits the accuracy of propagation modelling.

Details of the Concern.—Geoacoustic information is required as inputs to acoustic models used for predicting sound levels, which in turn are needed to gauge impacts on and establish

mitigation measures for marine mammals. Both 2-D and 3-D seismic exploration programs in the Canadian Beaufort Sea have expanded into new areas in recent years. For most areas of interest in the Canadian Beaufort Sea, there is only limited available information describing the following:

- bathymetry
- subsea permafrost distribution
- bottom type (via core samples, shallow hazard surveys)
- bottom roughness
- under ice roughness
- SVP in water column (spatial, temporal)
- SVP in the seafloor
- density profiles in the seafloor

In fact, many areas of interest (e.g., offshore Banks Island) have virtually no geoaoustic data.

Relevance to Regulatory Issues.—Regulators require information on acoustic footprints (impact radii) from seismic survey sources to guide their decisions on suitable mitigation approaches and potential impacts on marine mammals. In addition, for purposes of establishing potential lease options in the Canadian Beaufort, estimates of acoustic propagation that depend on geoaoustic information may influence which areas become available for lease. Also, the inclusion of reliable and detailed geoaoustic data in acoustic modelling will likely increase the willingness of regulators to trust and use acoustic model predictions.

Suggested Approach.—A two pronged approach was suggested, including creation of a geoaoustics parameter catalogue and a modelling sensitivity study. The creation of the catalogue would involve a search for and compilation of existing geoaoustic data from various sources, including previous studies by industry and government. It would allow for easy access to information and for examination of important spatial and temporal data gaps by groups conducting propagation modelling. A modelling sensitivity study would investigate the importance of geoaoustic parameters in terms of the influence of each parameter on predicted sound levels in the water.

Completion of the geoaoustics parameter catalogue and the modelling sensitivity study would allow researchers to make recommendations for directed field studies to address identified data gaps. Possible approaches to address anticipated data gaps include bathymetric studies, high-resolution seismic studies, coring, and grab samples.

Expected Outcome and Estimated Cost.—The expected outcome of the recommended study includes a catalogue of geoaoustic information that could be used in models for estimating acoustic footprints (i.e., impact radii) from seismic survey sources (or other noise sources). Other outcomes include a report identifying the importance of individual geoaoustic parameters in terms of their influence on acoustic model estimates and recommendations for directed studies to fill identified data gaps. The breakout group provided very approximate cost estimates of \$50,000 for each of the modelling sensitivity study and geoaoustics parameter catalogue.

Impact Radii and CSEL Approaches

Rapporteur: Dr. W. John Richardson

Data Gap/Procedural Issue.—Workshop participants acknowledged that there is a need to take a broad look at the mitigation approaches relating to impact radii currently applied in the Canadian Beaufort Sea in comparison to those used or recommended elsewhere. It is acknowledged that this data gap, though involving various acoustic issues within the scope of the present workshop, also involves biological issues that in a strict sense were outside the scope.

Details of the Concern.—A wide variety of mitigation approaches, monitoring requirements, and impact criteria are applied in different jurisdictions. Even within different Canadian regions, there are differences. The overall process typically involves numerous steps including but not limited to the following:

- initial identification of acceptable and unacceptable degrees of impact on marine animals;
- identification of impact criteria, including their units of measurement;
- translation of criteria into mitigation measures to be applied before and during the field program, including establishment of mitigation radii;
- real-time monitoring, as needed, to implement certain mitigation measures; and
- compilation and analysis of observations on effectiveness of monitoring and mitigation.

There is a need to take a broad look at the approaches currently applied in the Canadian Beaufort Sea in comparison to those used or recommended for use elsewhere. Questions to be addressed should include the following:

- Are current procedures (including mitigation radii) appropriate relative to now-available scientific data on biological effects?
- To what extent is the current approach overly conservative, about right, or not adequate?
- Should mitigation radii be based on received sound level vs. distance, and if so, how should sound levels be measured (e.g., rms, SEL for highest-level pulse, or CSEL)?
- If CSEL across an extended period of exposure is to be considered, how should the duration of accumulation be defined?
- Should received sound levels be frequency-weighted in relation to frequency-related differences in known or assumed hearing processes in marine mammals? If so, what weighting approach should be used? Should the same or different weighting procedures be applied when considering auditory effects vs. disturbance vs. masking? If frequency weighting is applied, how will that affect impact and mitigation radii and their practical application in the field?
- How precautionary should the process be, both overall and at individual steps in the monitoring and mitigation process?
- What are the tradeoffs and risks if precautionary procedures lead to longer-duration surveys?

The breakout group noted that there is concern about the possibility of auditory impairment or injury, behavioural disturbance, and masking and that these concerns should be distinguished.

Although all of the concerns should be addressed, the prevailing view of the breakout group was that emphasis should be placed on auditory impairment and injury.

Relevance to Regulatory Issues.—Specification of required mitigation measures is a key aspect of regulation, and establishment of mitigation radii is a major part of this process. There is a need to understand the linkages among sound exposure, acoustic metrics, mitigation measures, and biological effects.

Suggested Approach.—This topic should be addressed through an office-based review, analysis and integration of existing information and ideas in a variety of relevant fields. A collaborative team approach is needed. The team should include persons with knowledge of relevant aspects of acoustics, biology, the offshore oil and gas industry, and regulation. Also, one or more people with a broad systems-oriented view of all these aspects should be included to ensure an integrated approach. Emphasis should be on how mitigation radii can be defined in terms of sound levels and distance. However, this will require discussion of broader operational, physical acoustics, and biological issues. The project team will need to allow for what is known about seismic sound levels, propagation, environmental effects on sound, units of measurement, biological effects, and variability and uncertainty in all of these components. The connections between variability/uncertainty and the most appropriate degree of caution should be explored. For example, if the percentage of animals expected to incur a given effect diminishes with increasing distance, how should the specified mitigation distance be defined relative to the decline in percentage affected relative to distance?

The study should include a review of current practices in Canada (especially, but not exclusively, in the Beaufort Sea region) in relation to approaches elsewhere in the world where impact radii have been specifically implemented or recommended. Impact radii relevant to injury risk, behavioural disturbance, and masking need to be distinguished. It should be recognized that none of these types of potential impact is “all or nothing” in nature; impacts and impact radii have probabilistic attributes. There are variations in degree of impact and threshold for impact within as well as among marine mammal species. A risk assessment approach that allows for this variability would be appropriate.

Only limited additional acoustical modelling is likely to be needed for this review since existing model-based and empirical studies from the Beaufort Sea provide much of the needed acoustical information. However, some additional modelling work will probably be required when assessing whether or not mitigation based on CSEL might be preferable to mitigation based on sound exposure at closest point of approach (CPA), and if so, how mitigation radii allowing for CSEL might be defined, and how they would compare with radii based on maximum single-pulse exposures.

Expected Outcome and Estimated Cost.—A white paper that can be submitted to regulators and others in order to support a more biologically relevant, defensible, practical and understandable monitoring and mitigation approach. A very approximate cost estimate of \$100,000+ was provided by the breakout group.

Summary and Conclusions

The ESRF recognized that, with the granting of new exploration leases in the Canadian Beaufort Sea in recent years, hydrocarbon exploration through the use of 2-D and 3-D marine seismic programs would continue. The ESRF held a two-day workshop (July 14–15, 2009 in Calgary, Alberta) to address physical acoustics questions, specifically pertaining to modelling and measuring the characteristics, propagation, and received levels of seismic survey sound in the Canadian Beaufort Sea. The workshop was not intended to focus on the known and hypothesized effects of such seismic survey sounds on marine mammals. However, effects on bowhead and beluga whales and on the accessibility of beluga whales to Inuvialuit hunters are key reasons for interest in the physical acoustic properties of seismic survey sounds in the Canadian Beaufort Sea. Based on guidance from the ESRF, the emphasis of the workshop was mainly on empirical measurements and modelling of underwater sounds from marine seismic surveys, the most appropriate ways in which to measure these sounds (“metrics”), associated data gaps and procedural issues, and recommended studies.

During Day One of the workshop, experts in physical acoustics, particularly individuals with experience conducting empirical measurements and modelling of seismic survey sounds in the Canadian and Alaskan Beaufort Sea, presented findings from their work and discussed the limitations and data gaps. Presentations addressed the following main topics: Sound Metrics Relevant to Airgun Sounds, Modelling of Predicted Airgun Sound Levels, Empirical Measurements of Airgun Sounds, and Pre-season Modelling and Empirical Comparisons. Appendix E includes the PowerPoint presentations provided by the presenters. Brief summaries of the presentations are included in the report, in some cases providing explanatory information that may be helpful in following the corresponding PowerPoint presentation.

Day Two of the workshop involved further discussion of data gaps, including narrowing down a long list of gaps identified on Day One to shorter lists. With guidance from the ESRF, the participants were instructed to select the three most important and relevant data gaps pertaining to seismic survey sound propagation in the Beaufort Sea in order to build a suggested study design around each of these gaps. Workshop participants were divided into three breakout groups to outline a study design for each of the three key data gaps and procedural issues (see list below, which is in no particular order):

1. Ensure better sharing of information between industry organizations and regulators concerning (a) sound metrics relevant to airgun pulses and (b) related mitigation measures for marine mammals (i.e., safety zones or impact radii);
2. Provide better site-specific information on geoacoustic properties of the bottom of the Beaufort Sea, along with accurate water depth and SVP data, as inputs for sound propagation modelling; and
3. Examine mitigation approaches related to impact radii currently applied in the Canadian Beaufort Sea in comparison to those used or recommended elsewhere.

The breakout group addressing data gap and procedural issue (1) noted that some regulators, industry representatives, media representatives, and other stakeholders do not have a firm grasp of issues related to potential impacts of underwater sounds associated with geophysical surveys

and that this often leads to misunderstandings about key issues. The group recommended that a computer-based instructional package with modules on geophysical surveys, underwater sound, marine mammal biology, potential impacts, and mitigation and monitoring be developed. The instructional package, if properly designed and distributed, would result in better informed participants in the regulatory process, who would operate from a common knowledge base.

Geoacoustic data are key parameters in acoustic propagation models. The breakout group addressing data gap and procedural issue (2) noted numerous types of additional data that are needed for the Canadian Beaufort Sea, including more comprehensive data on bathymetry, subsea permafrost distribution, bottom type, bottom roughness, under ice roughness, SVP in water column, SVP in the seafloor, and density profiles in the seafloor. A two-pronged approach to address this data gap was suggested, including the creation of a geoacoustics parameter catalogue for the Canadian Beaufort Sea and a modelling sensitivity study. The creation of the catalogue would involve a search for and compilation of existing geoacoustic data from various sources including previous studies by industry and government. It would allow for easy access to information and for examination of important spatial and temporal data gaps by groups conducting propagation modelling. A modelling sensitivity study would investigate the importance of geoacoustic parameters in terms of the influence of each parameter on predicted sound levels in the water. Completion of the geoacoustics parameter catalogue and modelling sensitivity study would allow researchers to make recommendations for directed field studies to address identified data gaps.

The breakout group addressing data gap and procedural issue (3) noted that a wide variety of mitigation approaches, monitoring requirements, and impact criteria are applied in different jurisdictions. Even within Canadian regions, there are differences. Consequently, there is a need to take a broad look at the approaches, particularly for impact radii, currently applied in the Canadian Beaufort Sea in comparison to those used or recommended for use elsewhere. It was recommended that this topic be addressed through use of an office-based review, analysis and integration of existing information and ideas in a variety of relevant fields. Emphasis should be on how impact radii can be defined in terms of sound levels and distance. However, this will require discussion of broader operational, physical acoustics, and biological issues. The study should include a review of current practices in Canada (especially, but not exclusively, in the Beaufort Sea region) in relation to approaches elsewhere in the world where impact radii have been specifically implemented or recommended. Limited additional modelling work will probably be required when assessing whether or not mitigation based on CSEL (cumulative sound exposure level) might be preferable to mitigation based on sound exposure at CPA (closest point of approach), and if so, how mitigation radii allowing for CSEL might be defined, and how they would compare with radii based on maximum single-pulse exposures.

All three recommended studies would help regulators to support a more scientifically defensible, understandable, and biologically relevant monitoring and mitigation approach for seismic surveys in the Beaufort Sea.

References and Reviews

(cited in the report, plus other relevant documents)

- Abgrall, P., V.D. Moulton and W.J. Richardson. 2008. Updated review of scientific information on impacts of seismic survey sound on marine mammals, 2004-present. LGL Rep. SA973-2. Rep. from LGL Limited, St. John's, NL and King City, ON, for Department of Fisheries and Oceans, Habitat Science Branch, Ottawa, ON. 28 p. + appendices.
- Buck, B.M. and C.R. Greene. 1964. Arctic deep-water propagation measurements. **J. Acoust. Soc. Am.** 36:1526-1533.
- Cummings, W.C., D.V. Holliday and B.J. Graham. 1981. Measurements and localization of underwater sounds from the Prudhoe Bay region, Alaska, March, 1981. Environ. Assess. Alaskan Cont. Shelf, Final Rep. Princ. Invest., NOAA, Juneau, AK 19: 393-444. 565 p. NTIS PB85-200939.
- Finneran, J.J., C.E. Schlundt, D.A. Carder, J.A. Clark, J.A. Young, J.B. Gaspin and S.H. Ridgway. 2000. Auditory and behavioral responses of bottlenose dolphins (*Tursiops truncatus*) and a beluga whale (*Delphinapterus leucas*) to impulsive sounds resembling distant signatures of underwater explosions. **J. Acoust. Soc. Am.** 108(1):417-431.
- Gedamke, J., S. Frydman and N. Gales. 2008. Risk of baleen whale hearing loss from seismic surveys: preliminary results from simulations accounting for uncertainty and individual variation. Intern. Whal. Comm. Working Pap. SC/60/E9. 10 p.
- Gordon, J., D. Gillespie, J. Potter, A. Frantzis, M.P. Simmonds, R. Swift and D. Thompson. 2004. A review of the effects of seismic surveys on marine mammals. **Mar. Technol. Soc. J.** 37(4):16-34.
- Greene, C.R. 1985. Characteristics of waterborne industrial noise, 1980-84. p. 197-253 In: W.J. Richardson (ed.), Behavior, disturbance responses and distribution of bowhead whales *Balaena mysticetus* in the eastern Beaufort Sea, 1980-84. OCS Study MMS 85-0034. Rep. from LGL Ecol. Res. Assoc. Inc., Bryan, TX, for U.S. Minerals Manage. Serv., Reston, VA. 306 p. NTIS PB87-124376. Available at http://www.mms.gov/alaska/reports/1980rpts/85_0034/85_0034b.pdf
- Greene, C.R., Jr., and W.J. Richardson. 1988. Characteristics of marine seismic survey sounds in the Beaufort Sea. **J. Acoust. Soc. Am.** 83(6):2246-2254.
- Greene, C.R., Jr. 1998. Underwater acoustic noise and transmission loss during summer at BPXA's Liberty Prospect in Foggy Island Bay, Alaskan Beaufort Sea. Greeneridge Rep. 189-1. Prepared for BP Exploration (Alaska) Inc., Anchorage, AK, by Greeneridge Sciences, Inc., Santa Barbara, CA, and LGL Ltd., environmental research associates, King City, Ontario, Canada. 47 p.
- Greene, C.R., Jr., M.W. McLennan, R.G. Norman, T.L. McDonald, R.S. Jakubczak and W.J. Richardson. 2004. Directional Frequency and Recording (DIFAR) sensors in seafloor recorders to locate calling bowhead whales during their fall migration. **J. Acoust. Soc. Am.** 116(2):799-813.
- Harris, R.E., G.W. Miller and W.J. Richardson. 2001. Seal responses to airgun sounds during summer seismic surveys in the Alaskan Beaufort Sea. **Mar. Mamm. Sci.** 17(4):795-812.
- Harris, R.E., R.E. Elliott and R.A. Davis. 2007. Results of mitigation and monitoring program, Beaufort Span 2-D marine seismic program, open-water season 2006. LGL Rep. TA4319-1. Rep. from LGL Ltd., King City, Ont., for GX Technology Corp., Houston, TX. 48 p.
- Hildebrand, J. 2005. Impacts of anthropogenic sound. p. 101-124 In: J.E. Reynolds III, W.F. Perrin, R.R. Reeves, S. Montgomery and T.J. Ragen (eds.), Marine mammal research: conservation beyond crisis. Johns Hopkins Univ. Press, Baltimore, MD. 223 p.

- Holliday, D.V., W.C. Cummings and B.J. Lee. 1984. Acoustic and vibration measurements related to possible disturbance of ringed seals, *Phoca hispida*. Tracor Doc. T-84-06-001-U. Report from Tracor Appl. Sci., San Diego, CA, for Nat. Oceanic & Atmos. Admin., Juneau, AK. 148 p.
- Junger, M.C. and D. Feit. 1972. Sound, structures, and their interaction. MIT Press, Cambridge, U.S.A.
- Kastak, D., B.L. Southall, R.J. Schusterman and C. Reichmuth Kastak. 2005. Underwater temporary threshold shift in pinnipeds: effects of noise level and duration. **J. Acoust. Soc. Am.** 118(5):3154-3163.
- LGL Limited. 2008. Environmental assessment of GX Technology's marine vibroseis research project, March-May 2008. LGL Rep. SA971-2. Rep. from LGL Limited, St. John's, NL for GX Technology Canada Ltd., Calgary, AB. 100 p. + appendices.
- Ljungblad, D.K., B. Würsig, R.R. Reeves, J.T. Clarke and C.R. Greene. 1984. Fall 1983 Beaufort Sea seismic monitoring and bowhead whale behavior studies. Rep. for Minerals Management Service, Alaska OCS Region. 188 p.
- Ljungblad, D.K., B. Würsig, S.L. Swartz and J.M. Keene. 1988. Observations on the behavioral responses of bowhead whales (*Balaena mysticetus*) to active geophysical vessels in the Alaskan Beaufort Sea. **Arctic** 41(3):183-194.
- Lucke, K., U. Siebert, P.A. Lepper and M.-A. Blanchet. 2009. Temporary shift in masked hearing thresholds in a harbor porpoise (*Phocoena phocoena*) after exposure to seismic airgun stimuli. **J. Acoust. Soc. Am.** 125(6):4060-4070.
- Miller, G.W., R.E. Elliott, W.R. Koski, V.D. Moulton and W.J. Richardson. 1999. Whales. p. 5-1 to 5-109 *In*: W.J. Richardson (ed.), Marine mammal and acoustical monitoring of Western Geophysical's open-water seismic program in the Alaskan Beaufort Sea, 1998. LGL Rep. TA2230-3. Rep. from LGL Ltd., King City, Ont., and Greeneridge Sciences Inc., Santa Barbara, CA, for Western Geophysical, Houston, TX, and U.S. Nat. Mar. Fish. Serv., Anchorage, AK, and Silver Spring, MD. 390 p.
- Miller, G.W., V.D. Moulton, R.A. Davis, M. Holst, P. Millman, A. MacGillivray and D. Hannay. 2005. Monitoring seismic effects on marine mammals—southeastern Beaufort Sea, 2001-2002. p. 511-542 *In*: S.L. Armsworthy, P.J. Cranford and K. Lee (eds.), Offshore oil and gas environmental effects monitoring/approaches and technologies. Battelle Press, Columbus, OH. 631 p.
- Moulton, V.D. and J.W. Lawson. 2002. Seals, 2001. p. 3-1 to 3-48 *In*: W.J. Richardson and J.W. Lawson (eds.), Marine mammal monitoring of Westerngeco's open-water seismic program in the Alaskan Beaufort Sea, 2001. LGL Rep. TA2564-4. Rep. from LGL Ltd., King City, Ont., for WesternGeco LLC, Anchorage, AK; BP Explor. (Alaska) Inc., Anchorage, AK; and Nat. Mar. Fish. Serv., Anchorage, AK, and Silver Spring, MD. 95 p.
- Moulton, V.D., P. Abgrall, M. Holst and W.E. Cross. 2009. Efficacy of operational mitigation measures used to minimize impacts of seismic survey sound on marine mammals. LGL Rep. SA1019-1. Rep. from LGL Limited, St. John's, NL, King City, Ont., and Sidney, B.C., for Department of Fisheries and Oceans, Habitat Science Branch, Ottawa, Ont. 32 p. + appendix.
- Nowacek, D.P., L.H. Thorne, D.W. Johnston and P.L. Tyack. 2007. Responses of cetaceans to anthropogenic noise. **Mammal Rev.** 37(2):81-115.
- Richardson, W.J. and C.I. Malme. 1993. Man-made noise and behavioral responses. p. 631-700 *In*: J.J. Burns, J.J. Montague and C.J. Cowles (eds.), The bowhead whale. Spec. Publ. 2. Soc. Mar. Mammal., Lawrence, KS. 787 p.
- Richardson, W.J. and B. Würsig. 1997. Influences of man-made noise and other human actions on cetacean behav-

- our. **Mar. Freshwat. Behav. Physiol.** 29(1-4):183-209.
- Richardson, W.J., B. Würsig and C.R. Greene, Jr. 1986. Reactions of bowhead whales, *Balaena mysticetus*, to seismic exploration in the Canadian Beaufort Sea. **J. Acoust. Soc. Am.** 79(4):1117-1128.
- Richardson, W.J., C.R. Greene, Jr., C.I. Malme and D.H. Thomson. 1995. Marine mammals and noise. Academic Press, San Diego, CA. 576 p.
- Richardson, W.J., G.W. Miller and C.R. Greene, Jr. 1999. Displacement of migrating bowhead whales by sounds from seismic surveys in shallow waters of the Beaufort Sea. **J. Acoust. Soc. Am.** 106(4, Pt. 2):2281 (Abstract).
- Rutenko, A.N., S.V. Borisov, A.V. Gritsenko and M.R. Jenkerson. 2007. Calibrating and monitoring the western gray whale mitigation zone and estimating acoustic transmission during a 3D seismic survey, Sakhalin Island, Russia. **Environ. Monit. Assess.** 134(1-3):21-44.
- Sidorovskaia, N.A., A.M. Tashmukhambetov, G.E. Ioup and J.W. Ioup. 2005. Littoral acoustic demonstration center 2003 seismic calibration experiment: modeling acoustic energy distribution from seismic exploration array. **J. Acoust. Soc. Am.** 118(3):2002.
- Southall, B.L., A.E. Bowles, W.T. Ellison, J.J. Finneran, R.L. Gentry, C.R. Greene, Jr., D. Kastak, D.R. Ketten, J.H. Miller, P.E. Nachtigall, W.J. Richardson, J.A. Thomas and P.L. Tyack. 2007. Marine mammal noise exposure criteria: initial scientific recommendations. **Aquat. Mamm.** 33(4):i-iv, 411-522.
- Thomson, D.H., B.D. Fissel, J.R. Marko, R.A. Davis and G.A. Borstad. 1986. Distribution of bowhead whales in relation to hydrometeorological events in the Beaufort Sea. Environmental Studies Revolving Funds Report No. 028, Ottawa. 119 p.
- Tolstoy, M., J. Diebold, L. Doermann, S. Nooner, S.C. Webb, D.R. Bohnenstiehl, T.J. Crone and R.C. Holmes. 2009. Broadband calibration of the R/V *Marcus G. Langseth* four-string seismic sources. **Geochem. Geophys. Geosyst.** 10(8):1-15. doi: 10.1029/2009GC002451.

Acknowledgements

We would like to thank the ESRF for the opportunity to conduct this workshop and in particular Dave Kerr and Hugh Bain for handling logistics and Kym Hopper-Smyth for managing finances. We also extend our thanks to workshop presenters and other participants for taking time out of their busy schedules to participate in the workshop. The Canadian Association of Petroleum Producers (CAPP) was kind enough to provide their boardroom in Calgary for the workshop, thanks to the efforts of Paul Barnes, and the administrative staff was very supportive (notably Urszula Blaszcak, Anne Ward, and Michelle Williams). Ruby Martin of LGL was instrumental in managing workshop logistics and finances and Donna Hauser of LGL provided editorial assistance. Hugh Bain (DFO), Patrice Simon (DFO), and Dave Taylor (ESRF Secretariat) reviewed this document and we thank them for their input.



Presenters and organizers of the workshop. Front row (from left to right): Val Moulton (LGL), Dave Kerr (ESRF), Dr. Roberto Racca (JASCO), Hugh Bain (DFO), Dr. Susanna Blackwell (Greeneridge), Melania Guerra (Scripps). Back row (from left to right): Mike Jenkerson (ExxonMobil), Dr. Bill Ellison (MAI), Dr. John Richardson (LGL), Dave Hannay (JASCO), and Dr. Bill Burgess (Greeneridge). Missing from photo: Dr. John Diebold (L-DEO).

Dedication

This Proceedings volume is dedicated to the memory of Dr. John B. Diebold of Lamont-Doherty Earth Observatory of Columbia University, who participated in the workshop and passed away on July 1, 2010. John was involved in planning, conducting and interpreting academic seismic surveys for many years. He also facilitated the work of many other researchers involved in such research. In recent years, he was actively involved in addressing questions about the effects of marine seismic surveys on marine life, including modelling and empirical quantification of airgun signals. A summary of John's life and contributions can be found at <http://www.ldeo.columbia.edu/news-events/john-diebold-obituary>.

Appendix A: List of Acronyms and Key Definitions

AASM – Airgun array source model (e.g., Gundalf, Nucleus, JASCO’s AASM)

Airgun – A specialized acoustic sound source that creates underwater sound impulses by releasing a burst of compressed air into the water at a great velocity.

Acoustic Intensity – A fundamental measure of propagating sound, but is rarely measured directly. It is defined as the acoustical power per unit area in the direction of propagation; the units are watts/m². The intensity, power, and energy of an acoustic wave are proportional to the average of the pressure squared (mean square pressure) (for a more detailed discussion of acoustical issues see Chapter 2 in Richardson et al. 1995). For humans, sounds that are faint and barely perceptible have intensities near 1 pW/m², whereas those that are painful are near 10 watts/m².

Absolute Auditory Threshold – the minimum received sound level at which a sound with particular frequency and other properties can be perceived in the absence of significant background noise. A marine mammal can hear a fainter sound if the threshold is low than if it is high. The concepts of auditory threshold and auditory sensitivity are inversely related; a low threshold indicates high sensitivity, and vice versa.

AIM – Acoustic Integration Model. See *Presentations, Calculating CSEL: A Virtual Example Using AIM*.

Ambient Noise – The sea is a naturally noisy environment. The background noise caused by wave action and the sounds of ice and distant shipping is called ambient noise. This environmental background noise is not of direct interest during a measurement or observation.

ASA – American Standards Association.

ASAR (and DASAR) – (directional) autonomous seafloor acoustic recorder: Two particular designs for electronic recording devices that are deployed to the seafloor to record underwater acoustic data for a period of time determined by battery life, storage capacity, acoustic sampling rate, and duty cycle.

Broadband Sound – A sound that includes components over a wide range of frequencies. Music is typically a broadband sound. A tuning fork, in contrast, produces narrowband sound – close to a pure tone at a single frequency. An octave band is originally a musical term that includes 8 successive notes of the western musical scale or a range of frequencies where the upper limit is twice the lower limit. The bandwidth of a 1-octave band is 70.7% of its centre frequency.

CAPP – Canadian Association of Petroleum Producers.

CASS/GRAB – Comprehensive Acoustic System Simulation/Gaussian Ray Bundles. See *Presentations, Source Models for Airgun Arrays* (Follow-up Talk).

CPA – Closest Point of Approach.

CSEL – Cumulative Sound Exposure Level. See definition for SEL.

Decibel (dB) – The marine mammal ear is sensitive to sound energy across a broad range of frequencies. This response is logarithmic, rather than nonlinear; thus acousticians employ a logarithmic scale for sound intensities and levels, and denote the scale in *decibels*. In decibels, the *intensity level* of a sound of intensity I is given by the equation:

$$\text{Intensity Level (dB)} = 10 \log (I/I_0)$$

where I_0 is the reference intensity, for example, 1 pW/m^2 . Because intensity is proportional to pressure squared, the *sound pressure level* (SPL) of a sound pressure P is given by:

$$\text{Sound Pressure Level (dB)} = 20 \log (P/P_0)$$

where P_0 is the reference pressure, e.g., $1 \text{ }\mu\text{Pa}$. The phrase “sound pressure level” implies a decibel measure and that a reference pressure has been used as the denominator of the ratio.

E & P – Exploration and Production.

ENL – Exxon Neftegaz Limited.

Environmental Studies Research Funds (ESRF) – A body that funds research related to the oil and gas industry and is funded by a levy on participating companies.

FFT – Fast Fourier Transform.

Frequency-selective Weighting – a method of measuring sound pressure or energy in a specific frequency band by emphasizing or de-emphasizing particular frequencies depending on sensitivity to those frequencies. For marine mammals, special weighting functions (**M-weighting**) were proposed by Southall et al. (2007) based on consideration of weighting functions applied to humans along with information on marine mammal functional hearing bandwidths. M-weighting accounts for the fact that sounds at high and low frequencies must be more intense than sounds at intermediate frequencies in order to have equal auditory effect. The general M-weighting equation uses the estimated frequency cutoffs for each functional marine mammal hearing group, as follows:

$$M(f) = 20 \log_{10}(R(f)/\max\{|R(f)|\})$$

where

$$R(f) = (f^2_{high} f^2 / (f^2 + f^2_{high})(f^2 + f^2_{low}))$$

and the estimated lower and upper “functional” hearing limits (f_{low} and f_{high}) are described in Table 2 of Southall et al. (2007).

IAGC – International Association of Geophysical Contractors.

Impulse – A positive impulse is the sum of received pressure over time, from arrival of the leading edge of the pulse until pressure becomes negative. Impulse is measured in Pascal-seconds (Pa·s); as contrasted with pressure, in Pa; or total energy in the pulse, proportional to Pa²·s. Often used as a measure of blast, but not commonly used in relation to airgun sound.

Inverse-square Spreading Loss – Sound levels decrease with distance from a sound source due to several factors. The most pervasive of these, inverse-square spreading loss, is a geometrical decrease of SPL by 6 dB with every doubling of distance from a point sound source.

JASA – Journal of the Acoustical Society of America.

JIP – Joint Industry Program.

L-DEO – Lamont-Doherty Earth Observatory of Columbia University, New York.

Masking – Perception of biologically-important sounds is decreased due to interference by sound energy from other sources (including ambient noise). Masking is most pronounced if the interfering sound overlaps in frequency with the sound signal of interest.

Micropascal (μPa) – A Pascal is a standard unit of pressure in the SI system of units. One Pascal is the pressure resulting from a force of one newton exerted over an area of one square metre. Older reports use a different pressure unit, the dyne/cm², also called a microbar (μbar). A bar is the pressure of 0.986923 standard atmospheres. The microbar and micropascal are directly related: 1 μPa = 10⁻⁵ microbar.

MMO – Marine Mammal Observer.

MMS – Minerals Management Service.

NMFS – National Marine Fisheries Service, a part of the U.S. National Oceanic & Atmospheric Administration (NOAA).

PAM – Passive Acoustic Monitoring.

Peak level – In describing a transient sound, it is useful to present the *peak level* as well as some description of how the sound varies with time. The peak level is the absolute maximum instantaneous pressure. When transient sounds are so short as to be impulsive, they are best described in terms of their energy levels and energy density spectra.

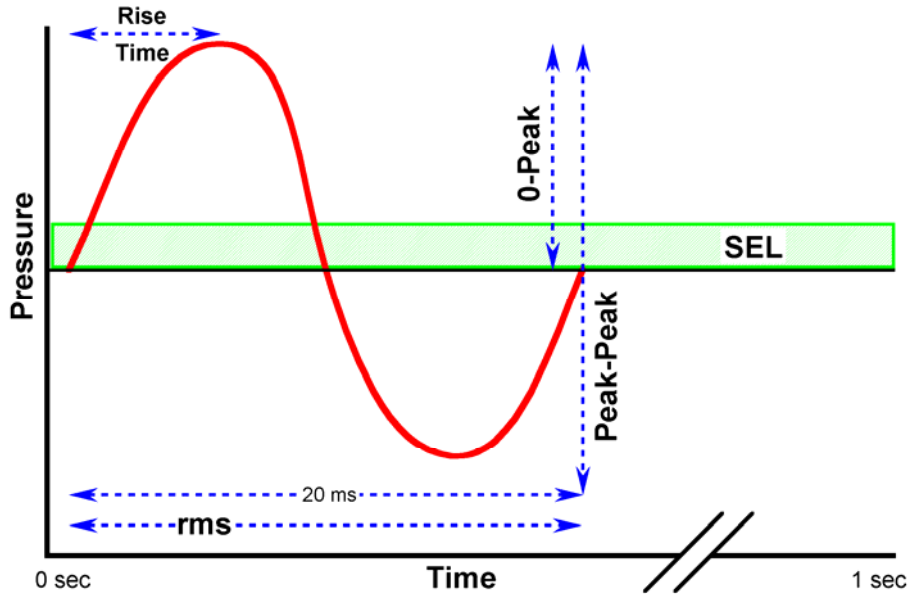

Permanent Threshold Shift (PTS) – Unlike TTS, PTS is a permanent decrease in hearing sensitivity caused by damage to auditory organs following exposure to sounds with high energy content, or large-amplitude pressure pulses.

RAM – Range-dependent Acoustic Model.

Received Sound Level – The sound level at a specific location, e.g., the location of an animal hearing a sound. Given a source with constant level over time, the received level (RL) will vary with distance from the source.

Root-mean-square (rms) level 1 – This is a type of average sound level over some defined interval.

Seismic survey – The offshore oil and gas industry uses seismic exploration techniques to evaluate the geology that underlies the sea. These techniques involve beaming powerful sounds into the ocean bottom and monitoring the return patterns. Modern vessels conducting marine seismic surveys using the streamer method are 80-95 m in length and have a crew of about 40 people. The vessels are capable of travelling at about 14 knots (26 km/h) when in transit with no equipment deployed. When seismic surveying equipment is in the water, vessel speed must be no less than 3.5 kts (6.5 km/h) and no more than 5.5 kts (10 km/h).

3-D Seismic survey – In areas where hydrocarbons are known to exist in economic quantities, it is usually cost-effective to acquire a 3-D seismic survey prior to design and construction of production facilities. A 3-D seismic survey provides a detailed ‘picture’ of the sub-surface, allowing the geoscientists and engineers to make realistic estimates of the amount and distribution of hydrocarbons within the reservoir. Marine 3-D seismic surveys are carried out using high pressure “airguns” for the sound source. The returning signals (echoes) are recorded,

during typical streamer surveys, by almost 3000 hydrophones which are towed behind the survey vessel.

2-D Seismic survey – Typically more regional in nature than are 3-D seismic surveys. Survey lines tend to be much farther apart (rarely closer than 1 km), and often are laid out in a number of different directions. The information that can be extracted from a 2-D seismic dataset is much more limited than that available from a 3-D seismic survey, but the 2-D is appropriate for exploring large areas relatively inexpensively with the intent of identifying areas that warrant further exploration, perhaps the acquisition of a 3-D survey or the drilling of an exploration well.

OBC Seismic Exploration – An Ocean Bottom Cable survey involves using a series of parallel receiving cables containing acoustic recorders (hydrophones) that are laid out in a “patch” rather than towed behind the vessel. The airgun array is towed back and forth across the OBC array and the acoustic energy of the airguns passes down into the underlying geological structures and is reflected back to the OBC receivers. The OBC method can only be used in shallow water. In very shallow water, it is the only method that can be used.

Sound Exposure Level (SEL) – The time-integral of the square pressure over a fixed time window long enough to include the entire airgun pulse (or other sound of interest). SEL has units of dB re $\mu\text{Pa}^2 \cdot \text{s}$. It is a measure of sound energy (or exposure) rather than sound pressure. SEL is a cumulative metric. SEL’s from multiple airgun pulses can be computed by summing (in linear energy) the SELs from multiple individual airgun pulses; this provides a measure sometimes referred to as CSEL (cumulative SEL).

Sound Pressure Level (SPL) – Animals respond to sound as pressure. The corresponding subjective measure of sound intensity, “loudness”, is closely proportional to pressure as long as the marine mammal is appropriately sensitive to the frequencies in the sound. For repetitive or continuous sound, a sound pressure level (SPL) is expressed as an average over a certain period of time. Because intensity is proportional to pressure squared, the *sound pressure level* (SPL) of a sound of pressure P is computed by:

$$\text{Sound Pressure Level (dB)} = 20 \log (P/P_0)$$

where P_0 is the reference pressure, e.g., $1 \mu\text{Pa}$. The phrase “sound pressure level” implies a decibel measure and that a reference pressure has been used as the denominator of the ratio. Sound pressure levels are related as follows:

$$\text{SPL (dB re } 1 \mu\text{Pa)} = \text{SPL (dB re } 1 \mu\text{bar)} + 100$$

$$\text{SPL (dB re } 1 \mu\text{Pa)} = \text{SPL (dB re } 0.0002 \mu\text{bar)} + 26$$

For example, an SPL of -40 dB re $1 \mu\text{bar}$, or re 1 dyne/cm^2 , is 60 dB re $1 \mu\text{Pa}$ (see Table 2.1 in Richardson et al. 1995).

SWSS – Sperm Whale Seismic Study.

SSV – Sound Source Verification.

Source Level (SL)– defined as the sound pressure level that would be measured at a standard reference distance (e.g., 1 m) from an ideal acoustic point source radiating the same amount of sound as the actual source being measured. This concept is necessary because sound

measurements near large, distributed sources like ships depend strongly on source size and measurement location, and are difficult to relate to levels measured far away. Near-field measurements are generally lower than would be obtained at the same distance from a point source radiating the same amount of energy.

Streamer – Cables, generally solid nowadays, that are towed 5 to 10 m below the surface of the water and contain the hydrophones. Seismic vessels tow one or more streamers, each of which is several thousand metres long.

SVP – Sound Velocity Profile.

Temporary Threshold Shift (TTS) – A temporary decrease in hearing sensitivity caused by exposure to sounds with high energy content, or large-amplitude pressure pulses.

Transmission Loss (TL or Propagation Loss) – A sound wave travelling from point A to point B diminishes in amplitude, or intensity, as it spreads out in space, is reflected, and is absorbed. If the source level (at 1 m) is 160 dB re 1 μ Pa-m, the received level at a distance of 1 km may be only 100 dB re 1 μ Pa; in this case TL is 60 dB. TL is generally expressed in dB, representing a ratio of powers, intensities, or energies of a sound wave at two distances from the source. The distance at which the denominator measurement was taken is the reference distance for TL. Because dB scales are logarithmic, and $\log(\text{ratio})$ equals $\log(\text{numerator})$ minus $\log(\text{denominator})$, TL can be expressed as the difference, in dB, between the levels at the two distances.

URI – University of Rhode Island.

Vibroseis – A geophysical assessment tool which involves the use of mechanical vibrators on ice or land as a seismic survey source.

WSS – Wide Sense Stationary.

Appendix B: Workshop Agenda

ESRF Workshop: Seismic Survey Sound Propagation in the Beaufort Sea

Day 1: 14 July 2009

Welcome/Introduction	
0830 – 0840 h	Welcome Hugh Bain, Dave Kerr (ESRF)
0840 – 0900 h	Introduction: Biological & Regulatory Context John Richardson (LGL)
Sound Metrics : Relevant to Airgun Sounds	
0900 – 0930 h	JIP Acoustic Standards Workshop / Discussion of Pk, SPL = rms, SEL, CSEL, Bandwidth Primary : Mike Jenkerson (ExxonMobil) Follow-up : Dave Hannay (JASCO), John Diebold (LDEO)
0930- 0945 h	Questions/Identification of Data Gaps
0945 – 1000 h	Quantifying Masking Effects of Seismic Survey Reverberation Off the Alaskan North Slope Melania Guerra (Scripps)
1000 – 1005 h	Questions/Identification of Data Gaps
1005 – 1025 h	Break
Modelling of Predicted Airgun Sound Levels	
1025 – 1055 h	Source Models for Airgun Arrays Primary : Diebold Follow-up : Bill Ellison (MAI)
1055 – 1110 h	Questions/Identification of Data Gaps
1110 – 1135 h	Propagation Modelling in Beaufort Sea Conditions Primary : Rob Racca (JASCO) Follow-up : none
1135 - 1150 h	Questions/Identification of Data Gaps
1150 – 1215 h	Impact Radii and CSEL Approaches Primary : Hannay Follow-up : Ellison
1215 – 1230 h	Questions/Identification of Data Gaps
1230 – 1330 h	Lunch (provided)
Empirical Measurements of Airgun Sounds	
1330 – 1355 h	Canadian Beaufort Sea Primary : Hannay Follow-up : Richardson
1355 – 1410 h	Questions/Identification of Data Gaps
1410 – 1435 h	Alaskan Beaufort Sea Primary : Bill Burgess (Greeneridge)

	Follow-up : none
1435 – 1450 h	Questions/Identification of Data Gaps
1450 – 1510 h	Break
1510 – 1540 h	Procedural Issues: in Field and in Analysis Primary : Susanna Blackwell (Greeneridge) Follow-up : Diebold
1540 – 1555 h	Questions/Identification of Data Gaps
Modelling – Empirical Comparisons	
1555 – 1625 h	Pre-season Modelling – Empirical Comparisons Primary : Hannay Follow-up : Jenkerson, Racca
1625 – 1640 h	Questions/Identification of Data Gaps
Vibroseis	
1640 – 1710 h	The Special Case of Underwater Sound from On-Ice Vibroseis General Discussion
Wrap-up/Planning	
1710 – 1730 h	Wrap-up and planning for Day 2 Richardson

Day 2: 15 July 2009

Data Gaps	
0830 – 1000 h	Review of Data Gaps Identified During Day 1 Facilitator: Richardson
1000 – 1020 h	Break
1020 – 1100 h	Identification of Additional Data Gaps General Discussion
Development of Experimental Design	
1100 – 1230 h	
1230 – 1330 h	Lunch (provided)
1330 – 1450 h	
1450 – 1510 h	Break
1510 – 1600 h	
Wrap-up	
1600 – 1620 h	Next Steps and Reporting Bain, Kerr

Appendix C: List of Workshop Participants

Attendee	Affiliation	E-mail address
Bain, Hugh	DFO	hugh.bain@df-mpo.gc.ca
Blackwell, Susanna	Greenridge Sciences	susanna@greeneridge.com
Brice, Tim	WesternGeco	tbrice@slb.com
Burgess, Bill	Greeneridge Sciences	burgess@greeneridge.com
Campbell, Steve	PGS	Steve.Campbell@pgs.com
Carr, Scott	JASCO Applied Sciences	scott.carr@jasco.com
Diebold, John	L-DEO	johnd@ldeo.columbia.edu
Ellison, William	Marine Acoustics Inc.	wemai@aol.com
Gagliardi, Joe	IONGEO	jgagliardi@iongeo.com
Gilders, Michelle	LGL Limited	mgilders@lgl.com
Graf, Linda	ConocoPhillips Canada	Linda.H.Graf@conocophillips.com
Guerra, Melania	Scripps Institution of Oceanography	melania@mpl.ucsd.edu
Hall, Matt	ConocoPhillips	Matt.Hall@conocophillips.com
Hall, Mike	IONGEO	mike.hall@iongeo.com
Hannay, Dave	JASCO Applied Sciences	David.Hannay@jasco.com
Jenkerson, Mike	ExxonMobil	Mike.Jenkerson@exxonmobil.com
Kerr, Dave	ESRF	Dave_Kerr@golder.com
Lemon, Dave	ASL Environmental	dlemon@aslenv.com
Moulton, Val	LGL Limited	vmoulton@lgl.com
Racca, Roberto	JASCO Applied Sciences	Roberto.Racca@jasco.com
Richardson, John	LGL Limited	wjr@lgl.com
Streever, Bill	BP Exploration (Alaska) Inc.	streevbj@BP.com
Taylor, Dan	Shell	Daniel.D.G.Taylor@shell.com
Tsoflias, Sarah	International Association of Geophysical Contractors	sarah.tsoflias@iagc.org

Appendix D: Data Gaps and Procedural Issues

The following “original” list of data gaps and procedural issues was compiled based on discussions during Day One of the workshop. In some instances, discussion during Day Two helped augment and clarify these gaps and issues. Gaps and procedural issues are organized by the five main topics of the workshop. The ❖ bullet symbol indicates the main data gap or procedural issue and the • bullet symbol indicates a follow-up point or related gap/procedural issue noted by the workshop participants.

Sound Metrics : Relevant to Airgun Sounds

- ❖ The relationship between SPL (rms) and SEL is quite variable because it depends on many factors including water depth, distance, etc.
 - Therefore, is it possible to use raw data from old studies (that mostly used rms metric) to calculate SEL or CSEL? If so, it may be possible to reshape key “historical” literature in terms of newer (+old) metrics.
 - If modelling SEL (e.g., by L-DEO), what procedure should be used to convert to SPL (rms) for regulatory purposes?
- ❖ A review / summary of possible metrics and measurement procedures is needed; standardization of measurement methodology needs to be settled. The JIP process for this task is ongoing.
- ❖ Long-term archiving and ability to retrieve older data needs consideration
- ❖ Appropriate background noise measures matched with seismic pulse measures are needed so we can determine signal to noise ratio.
 - A research cruise to address multiple data gaps including background noise, bottom conditions, etc. would be appropriate.
- ❖ Is SPL (rms) or SEL the more useful metric when assessing biological effects vs. sound exposure?
 - For behavioural effects, it would take expensive studies to test this question, and the results would probably be limited by small sample sizes.
 - For auditory effects of strong sounds vs. exposure, SEL metric would probably be better.
- ❖ What time window is appropriate to account for effects of multi-pathing?
 - Even SEL is subject to this effect.
- ❖ How to ensure that full waveform is accounted for in assessing potential impacts on marine mammals?
 - Both measurements and specific models are often limited in frequency range.

- ❖ There is a need for better sharing of information between industry and regulators.
Communication with / training of regulatory community, stakeholders and media to understand metrics, recent scientific developments, and associated issues; is this possible?
- ❖ Need to catalogue seafloor reflectivity for future operations given its effect on reverberation
 - This can be theoretically addressed from data collected during seismic surveys.
- ❖ Reverberation requires further examination:
 - Distinguishing ambient noise vs. reverberation (masking is the issue)
 - Should be considered as sound received by animals rather than by instruments “randomly” placed in the water column.

Modelling of Predicted Airgun Sound Levels

Source Models for Airgun Arrays

- ❖ How closely do outputs from different source models (e.g., Gundalf, Nucleus, JASCO’s AASM) compare with one another (as a function of frequency and angle), and with empirical data where available?
 - Some information is available for Gundalf model vs. Nucleus model vs. empirical data in the Gulf of Mexico.
 - What is accuracy of nearfield model of sources?
 - How confident are we in SL calculation?
- ❖ There is a need to test accuracy of modelling for airguns in clusters and for GI guns
 - Nucleus model has been tested for clusters, PGS has done this at frequencies <1 kHz; JIP study will test modelling accuracy for frequencies >1 kHz.
 - JIP study will do this for common airgun cluster configurations
- ❖ How does array tilting and torquing (not normally documented in field) affect SL?
 - Differences are large enough to be significant at high frequencies.
 - Airgun timing change can be a factor at high frequencies.
- ❖ There is a need to characterize array performance at higher frequencies (e.g., >1 kHz) as it relates to accuracy of modelling of high frequency sound output from an array. JIP has undertaken a related study.

Propagation Modelling in Beaufort Sea Conditions

- ❖ How does ice affect propagation of seismic survey sound?
 - This is becoming more of an issue as seismic programs expand offshore.
 - Some information on under ice sound propagation from Navy work.

- Any there any useful propagation data from 2008 BIO *Amundson* and *Healy* cruise?
- ❖ There are limited data on geoacoustic properties, particularly water depth and SVP in the Beaufort Sea. Also:
 - Data are considered to have poor spatial coverage.
 - Relic permafrost information (distribution and properties) is scarce; compilation and statistical characterization of existing accessible data could be useful.
 - Effects of high shear speed (when it occurs) may be important and if so a real challenge to address with propagation modelling – seafloor and sub-bottom conditions are key.
 - Potential influence of old river channels requires investigation; compilation of existing data would help.
 - High-resolution bottom data would be useful for models, especially at high frequencies.
 - Sensitivity analysis on these issues could help in prioritizing these data gaps.
- ❖ What sensitivities in model parameters influence output?
 - JIP is doing a study later in 2009 to review propagation modelling: are there ways to get key parameters by iterative calibrations?
- ❖ There is limited validation/calibration on propagation modelling in Beaufort and Chukchi seas even though it is more complex than source modelling.
- ❖ Most acoustic models are 2-D—do not allow for horizontal (transverse) curving/reflections, e.g. around an island or in a fiord.
- ❖ Are there alternatives to RAM/PE models that should be used for seismic? When?
 - JIP's new review will consider this.
- ❖ Production of an “intelligent” algorithm that selects appropriate procedure for given conditions would be very useful.

Impact Radii and CSEL Approaches

- ❖ There is need for a review of existing vs. possible alternative methods, criteria, degree of precaution, etc., for determining impact radii. Consideration should be given to:
 - Is M-weighting appropriate?
 - How to go from the irregular acoustic footprint of an airgun pulse to single impact radius?
 - CSEL, including an appropriate decay rate.
- ❖ Low TTS (and thus PTS) thresholds in some pinnipeds (and perhaps porpoises, where they occur) are a concern.
 - A JIP study on TTS in arctic seals is planned.

- ❖ There is a need to improve realism of animal movement assumptions in AIM and similar models.
 - Appropriate aversion (and attraction) rules for marine mammals exposed to seismic sound should be accounted for in these models.
- ❖ In estimating CSEL, is there a “reset” (or decay constant) on accumulation of pulse exposures?
 - After what interval (or decay rate) should energy accumulation stop? This is a biological question not a physical acoustics question.
 - How do background sound levels contribute to CSEL? Does “equivalent quiet” concept apply in marine mammals?
- ❖ What is the residency of marine mammals in a given area where seismic surveys may occur?
- ❖ What are the implications of marine mammals that are attracted to array?

Empirical Measurements of Airgun Sounds

Canadian and Alaskan Beaufort Sea

- ❖ What is the relationship between RL vs. depth in water column?
 - It is difficult to measure sound threshold distances in deep water due to depth dependence.
 - There is a near surface fall-off in RL, especially near airguns.
 - RL are needed for event reconstruction.
- ❖ High-frequency sampling is needed to determine frequency above which pulse components are below noise level.
 - There is a need to systematically evaluate what audio frequencies are relevant given source spectra, absorption, odontocete audiograms, etc.
 - JASCO usually samples at 48 kHz now; sometimes at 96 kHz.
- ❖ There is a need to consider dive behaviour of animals in deep water relative to RL vs. depth data. Threshold distances should relate to dive depths of species of interest.
- ❖ Can smaller airguns in back of an array create a bubble that reduces RL from larger airguns in the front when looking at stern aspect?
 - One study gave 15 dB difference in stern vs. bow aspects in 8 m water depth but not in 23 m depth.

- ❖ Repeated use of selected reference tracks was suggested to get comparable data on effect of different sources, source depths, aspects, upslope vs. downslope, etc .
 - An office analysis to identify candidate reference tracks would be the first step to address this data gap, followed by a field study.
- ❖ There is a need to understand differences in shallow vs. deep water propagation and RLs in the Canadian Beaufort.
- ❖ What is the temporal pattern of SL and RL during ramp up?
 - Modelled and empirical measurements are required: OGP/IAGC Task Force has funded a study to address ramp up questions.
 - Does ramp-up work? This is considered a biological question which would be costly to address adequately; JIP is considering this study.
- ❖ Do shoal waters or barrier islands block sound?
- ❖ How does sound propagate between gaps in barrier islands?

Procedural Issues in Field and in Analysis

- ❖ Prepare a paper on selected aspects of standardized field and analytical approaches about received levels of airgun sounds; coordinate with JIP standardization process (see “Metrics” section, above).
 - If one needs to know “distance to low RL” like 120 dB, sound measurements are required at long ranges.
- ❖ An optimum source track is needed to get both endfire and broadside RL.
 - RL vs. range curves can have quite different shapes as well as levels.
- ❖ The frequency range sampled in the field should include high frequencies.
 - Components up to several kHz are weak relative to low frequencies but still can be substantial.
 - Higher frequencies are important when M-weighting for odontocetes is applied, which emphasize high frequencies.
- ❖ What is the best curve fitting approach in analyses?
 - Best fit regression *or* best fit + x dB (to include all points) *or* best fit + 95th percentile?
 - Separate curves should be used for different depths (or depth should be used as a parameter in more complex curve fitting procedures).
- ❖ Pulse analysis: energy method for SEL; determine 90% SPL for comparisons.

- ❖ How should outlier data be treated?
- ❖ For frequency weighting: is the inverse audiogram (e.g., dB_{ht} approach) preferable to M-weighting when dealing with effects of low-level sounds on behaviour?

Modelling vs. Empirical Comparisons

- ❖ If assumed conditions in pre-season modelling do not match conditions for empirical measurements, re-run model for actual location, depth, SVP, and bottom type.
- ❖ Characterize variation in measurements, and the distribution of differences between model vs. measurements, and use results to assess whether an offset of some magnitude should be applied to model output.
 - Ensure that modelling depths match SSV measurements; this ties into procedures used to acquire measurements.
- ❖ Can empirical data be used more effectively to improve future modelling?
 - JASCO currently uses field data to improve environmental data input and in suggesting alternate models, e.g., for steep angles.

On-Ice Vibroseis

- ❖ If there is a need for data on sounds from on-ice Vibroseis, start by trying to access existing unpublished results.

Appendix E: Presentations

Biological and Regulatory Context: A Brief Introduction

Dr. W. John Richardson, LGL Limited (Primary Talk)

Standardizing Methods of Measuring Underwater Noise

Michael R. Jenkerson, ExxonMobil (Primary Talk)

Sound Pressure Metrics

David E. Hannay, JASCO (Follow-up Talk)

Sound Metrics

Dr. John Diebold, L-DEO (Follow-up Talk)

Quantifying Masking Effects of Seismic Survey Reverberation off the Alaskan North Slope

Melania Guerra, Scripps (Primary Talk)

Source Models for Airgun Arrays

Dr. John Diebold, L-DEO (Primary Talk)

Source Models for Airgun Arrays

Dr. William T. Ellison, MAI (Follow-up Talk)

Propagation Modeling—Beaufort Sea Conditions

Dr. Roberto Racca, JASCO (Primary Talk)

Impact Radii and CSEL

David E. Hannay, JASCO (Primary Talk)

Calculating CSEL: A Virtual Example Using AIM

Dr. William T. Ellison, MAI (Follow-up Talk)

Empirical Measurements – Canadian Beaufort

David E. Hannay, JASCO (Primary Talk)

Variability of Seismic Sounds Recorded in the Alaskan Beaufort Sea

Dr. William C. Burgess, Greeneridge Sciences (Primary Talk)

Sound Source Verification: Procedural Issues in the Field and during Analysis

Dr. Susanna B. Blackwell, Greeneridge Sciences (Primary Talk)

Model-Data Comparison

David E. Hannay, JASCO (Primary Talk)

Pre-Season Modeling - Empirical Comparisons, Sakhalin Experiences

Michael R. Jenkerson, ExxonMobil (Follow-up Talk)

Seismic Sound Modeling Verification Against ENL 2001 Measurements

Dr. Roberto Racca, JASCO (Follow-up Talk)

Biological & Regulatory Context: A very brief introduction

W. John Richardson

LGL Ltd., environmental research associates
King City, Ont. – wjr@LGL.com

for

ESRF Workshop: Seismic Survey Sound Propagation
in the Beaufort Sea

Calgary, 14-15 July 2009



Biological & Regulatory Context:

What is their relevance to a workshop on physical acoustic issues such as

- metrics?
- modeling?
- empirical measurements?
- model/empirical comparisons?

Biological effects (known or suspected) are the reason why the physical acoustics of seismic sounds are of such strong concern.

Known or Suspected Biological Effects

- Audible
- Masking - usually minimal?
- Behavioral Disturbance
 - subtle / short-term
 - dramatic / longer term
- Auditory Impairment
 - temporary (TTS) ?
 - permanent (PTS) ?

Can Occur With

Low RL, i.e., to
large distance

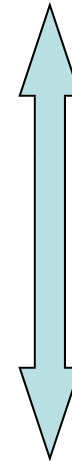

High RL, i.e., to
small distance

Known or Suspected Biological Effects

- Audible
- Masking - usually minimal?
- Behavioral Disturbance
 - subtle / short-term
 - dramatic / longer term
- Auditory Impairment
 - temporary (TTS) ?
 - permanent (PTS) ?
- Physiological problems ?

Can Occur With

Low RL, i.e., to
large distance

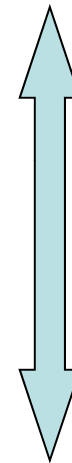

High RL, i.e., to
small distance

???

Known or Suspected Biological Effects

Onset (in mysticetes) at

- **Audible** → RL (received level) > ambient (10s-100s of km)
- **Masking** - usually minimal?
- **Behavioral Disturbance**
 - subtle / short-term → Highly variable RL, sometimes 120-150 dB re 1 uPa (rms)*, → roughly 10 - 50 km
 - dramatic / longer term → 160-170 dB re 1 uPa (rms)* → roughly 2 - 5 km
- **Auditory Impairment**
 - temporary (TTS) ? → Estimated from captive odontocetes (Southall et al. 2007) as ~183 dB re 1 uPa²-s (CSEL)**
 - permanent (PTS) ? → ~198 dB re 1 uPa²-s (CSEL)** → short distances, but difficult to estimate
- **Physiological problems ?** → ???

* **rms** = root mean square Sound Pressure Level

** **CSEL** = Cumulative Sound Exposure Level



see “Metrics” and “Impact Radii” presentations, later

Common Regulatory Thresholds

Some regulatory criteria are not well linked to biological effects:

- **500 m “safety” distance:**
 - originally based on sightability considerations, not biological effects
 - corresponds to widely varying received levels depending on source strength, aspect, & propagation conditions.
- **190, 180 and 160 dB re 1 uPa rms:**
 - each corresponds to widely varying distances, depending on those same factors
 - 190 and 180 dB “**safety criteria**” are largely arbitrary; no direct link to CSELs associated with TTS, PTS
 - 160 dB “**disturbance criterion**” came from mysticete studies but often assumed to apply to other mar. mammals; actual response threshold highly variable even in mysticetes.

Some Conclusions on Biological Effects & Regulatory Context

- Seismic sound exposures associated with onset of specified biological effects vary widely and are not well documented for most species and situations.
- To measure sound exposure, we need well-defined and biologically-relevant measures of received sound.
- Need to understand relationships of different sound measures
 - to one another;
 - to factors that affect source and received sound levels
- The most appropriate regulatory criteria may need to be expressed using different sound metrics than at present.
- **Understanding seismic sound levels is central to interpreting biological effects of seismic sound, and in establishing appropriate regulatory procedures.**

Sound Metrics: Relevant to Air Gun Sounds



Standardizing Methods of Measuring Underwater Noise

Mike Jenkerson

ESRF Workshop: Seismic Survey Sound Propagation in The Beaufort Sea
14th-15th July 2009

Motivation

- Acoustic data has been compiled both for seismic and non-seismic sources (Seiche)
- Acoustic data has been used in other studies (Behavior)
- Further data collection for E&P sources will probably be undertaken by the JIP and Industry and the JIP is likely to fund further studies involving acoustics
- A standard method for the acquisition and analysis of this data will facilitate better assessments and comparisons of E&P industry sounds
- This project will define a standard methodology (and equipment specifications) for the acquisition and analysis of E&P acoustic data that will allow new high quality comparable data to be acquired

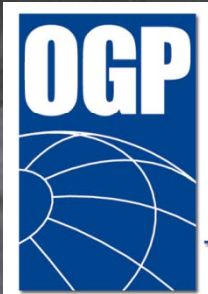

Strategy

- Conduct working groups on:
 - Analysis metrics, correction factors and calibrations
 - Acoustic acquisition equipment and methodology
- Determine the key acoustic metrics relevant to biological exposure assessments and any estimation of biological significance
- Provide standard acquisition methodologies and metrics which can be referenced by consultants/contractors or researchers working on JIP and industry E&P projects to improve experimental rigor and reporting consistency.
- If accepted, the standard will be published in a peer reviewed publication or as a defined standard (SEG or ASA). The standard could also be integrated with another appropriate standard if the integrity of the work conducted under the JIP standard is maintained.

www.soundandmarinelife.org/site/



International Association of Oil & Gas Producers

www.ogp.org.uk

Project Goals

- Ensure that results from JIP acoustic studies are reported using consistent metrics and that all required supporting data (e.g. window lengths, signal to noise) are recorded and reported, so studies can be appropriately compared
- Determine which metrics are most appropriate when discussing different features of an acoustic signal. This will include:
 - Methodologies for the analysis of transient and continuous acoustic data.
 - Methodologies for the analysis of velocity data.
 - Recommendations on the treatment of calibrations. (e.g. should the calibrations be defined as part of the analysis?)
 - Where possible establish the relationship between any new analysis metrics and those used in previous work, especially biological (e.g. damage or behavior) studies, and determine any correction factors to be applied to data acquired or analyzed in a non-standard manner to bring it to the standard.



Status

Working group on analysis metrics, correction factors and calibrations

- Workshop conducted in October 2007
- Draft standard – 3Q 2009
- Internal Review – end Q4 2009
- External Review – end Q1 2010
- JIP release standard – Q2 2010
- Publication - ?
- Integration of standard - ?

Working group on acoustic acquisition equipment and methodology

- Workshop will (hopefully) be conducted by Q1 2010
- Draft standard – Q2 2010
- Internal Review – Q3 2010
- External Review – Q4 2010
- JIP release standard – Q1 2011
- Publication - ?
- Integration of standard - ?



Acknowledgements

Workshop on analysis metrics, correction factors and calibrations

- **Tom Carlson - Battelle**
- **Bill Ellison - Marine Acoustic Inc**
- **Jim Finneran - US Navy Marine Mammal Program**
- **Ingebret Gausland – StatoilHydro**
- **Roger Gentry - JIP**
- **Charles Greene - Greenridge Sciences Inc**
- **David Hedgeland – PGS**
- **Mike Jenkerson - ExxonMobil**
- **Ron Kastelein -**
- **Darlene Ketten - WHOI/NIH - NIDCD/ Harvard Medical School**
- **Robert Laws – WesternGeco**
- **Jeremy Nedwell - Subacoustech**
- **Rob Racca - JASCO Research Ltd**
- **John Richardson - LGL Ltd**
- **Susan Blaeser - Acoustical Society of America**
- **Stephen Robinson/Richard Hazelwood – NPL (UK)**
- **Roy Wyatt – Seiche Measurements Ltd**

www.soundandmarinelife.org/site/



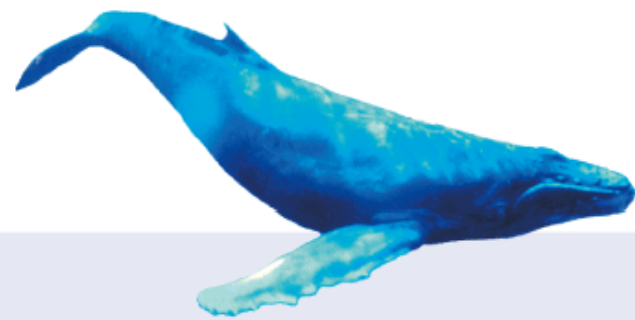
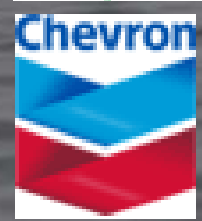

E&P Sound and Marine Life Programme

The E&P Sound and Marine Life Programme is an international consortium of oil & gas companies organised under OGP in London.

The Programme's objectives are to obtain scientifically valid data on the effects of the sounds produced by the E&P industry on marine life.

The project and website are in their initial stages. Please check back soon for additional information.





Sound Pressure Metrics

David Hannay, JASCO

**ESRF Workshop: Seismic Survey Sound
Propagation in the Beaufort Sea**



Overview

- Characteristics of pressure signatures (pressure versus time) of seismic sounds.
 - Metrics commonly used for evaluating seismic sound levels:
 - Introduction to decibels
 - Peak and Peak-to-Peak pressure, L_{pk}
 - Root-mean-square (RMS) pressure, L_p
 - Sound Exposure Level (SEL), L_E
 - Cumulative SEL
 - Frequency-weighting
-

Pulse sound at increasing ranges (change in amplitude and shape)

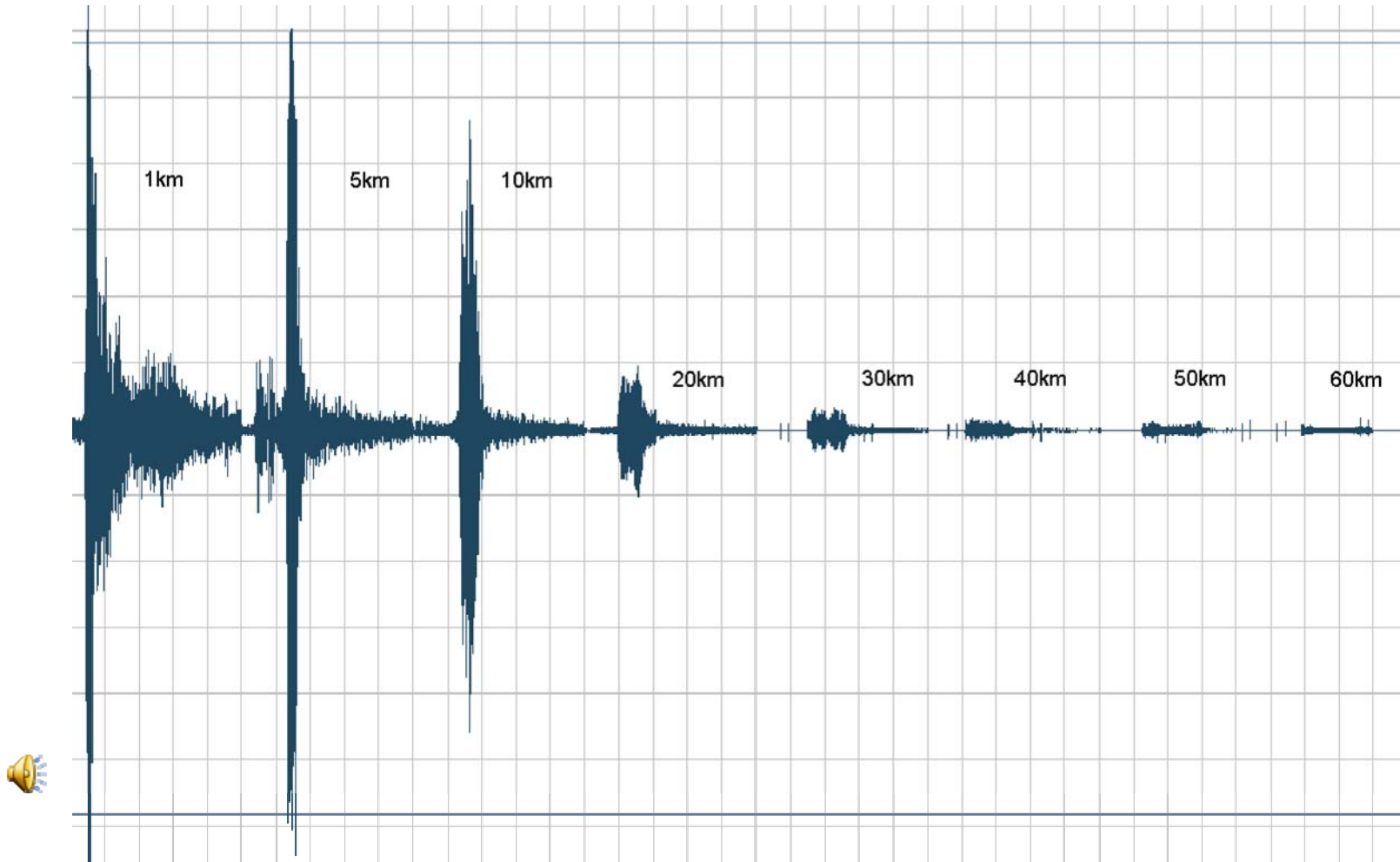

Decibels

- Sound levels are generally expressed in decibels (dB) relative to a reference pressure.
- The current standard pressure for underwater sound is one microPascal (1 μPa). The reference in air is 20 μPa .
- If we express pressure p in units of microPascals then the decibel level in dB re 1 μPa is:

$$L = 20 \log_{10}(p)$$

Peak and Peak-Peak Pressure

- Peak pressure is the maximum absolute pressure reached throughout the duration of the pulse.

$$L_{pk} = 20 \log_{10} (\max |p(t)|) \quad L_{p-p} = 20 \log_{10} (\max(p(t)) - \min(p(t)))$$

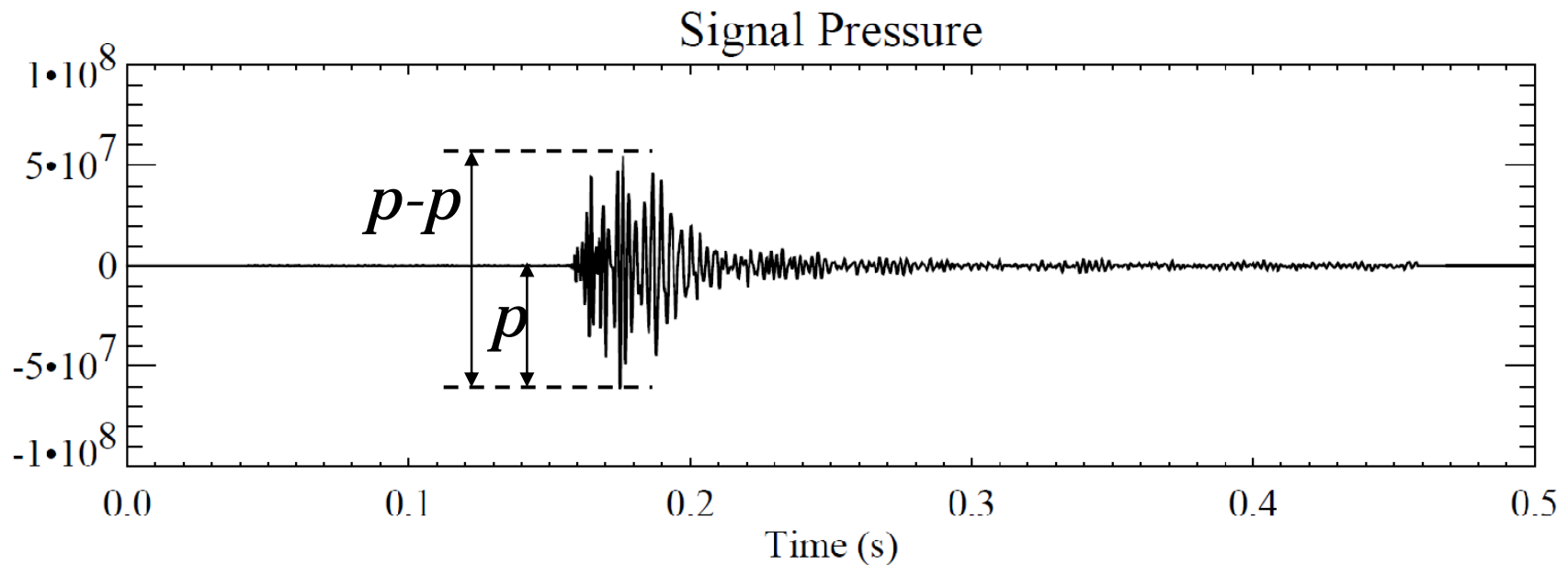

RMS Pressure (L_p)

- Root-mean-square pressure over pulse duration.
- Duration defined as the time period between receipt of 5% and 95% of cumulative square pressure.

$$L_p = 10 \log_{10} \left(\frac{1}{T} \int_T p^2(t) dt \right)$$

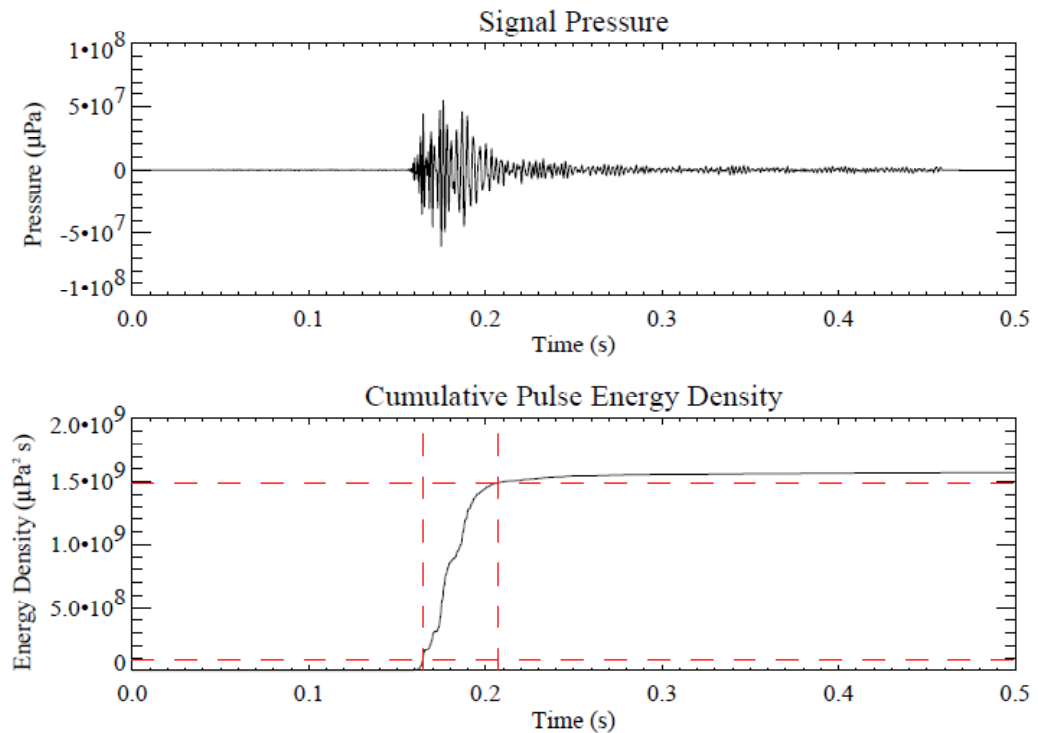

Sound Exposure Level (SEL)

- A measure of the amount of acoustic energy* received by the listener.
- Computed as the time integral of square pressure through a time period long enough to capture the *entire* pulse.

$$L_E = 10 \log_{10} \left(\int_T p^2(t) dt \right)$$

* Energy flux density for plane waves is $E = \frac{1}{\rho c} \int p^2(t) dt$

Cumulative SEL

- Cumulative SEL is simply a running total of previously-received SEL.

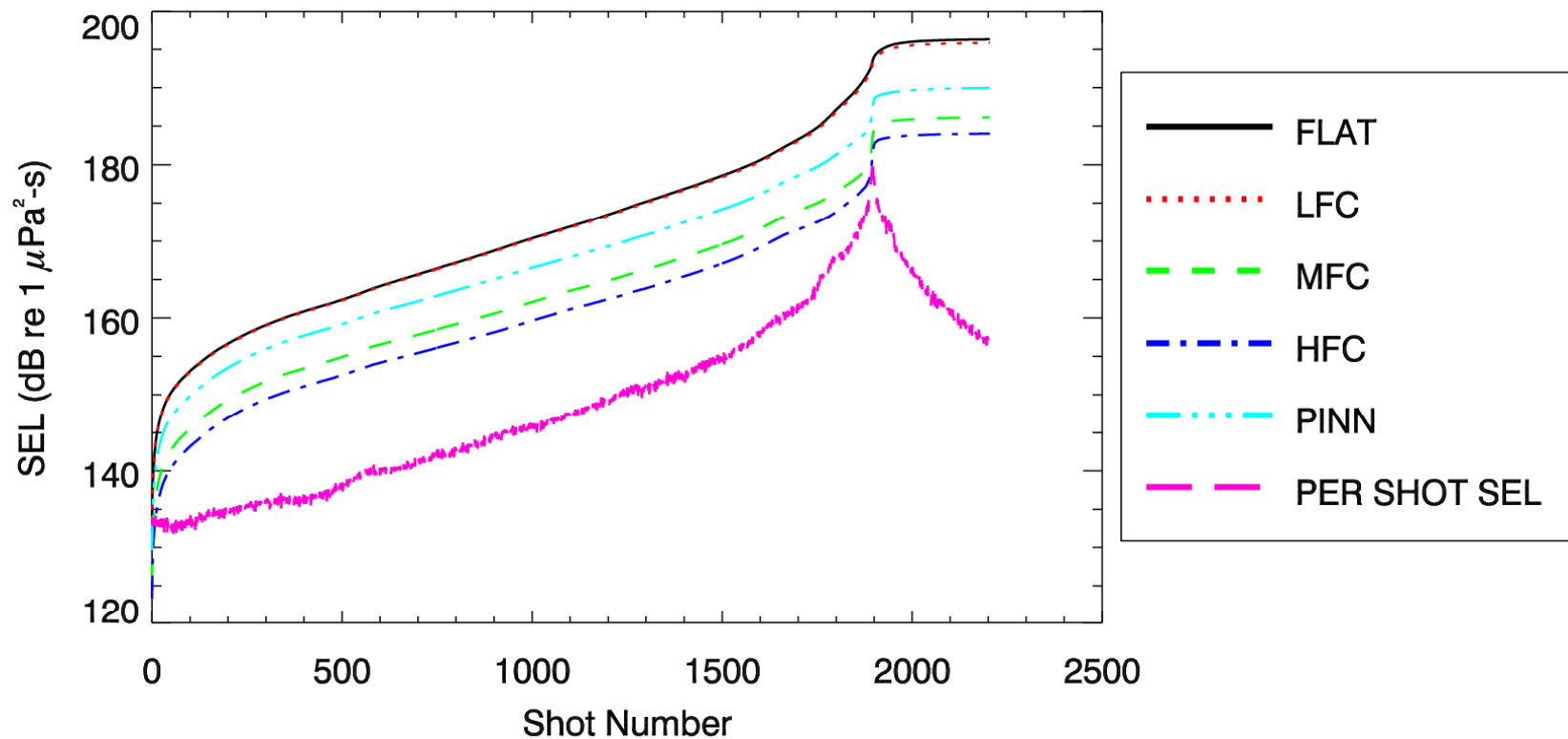

M-Weighting

- Discounts sound energy if it is outside the hearing frequency range of specific species group.

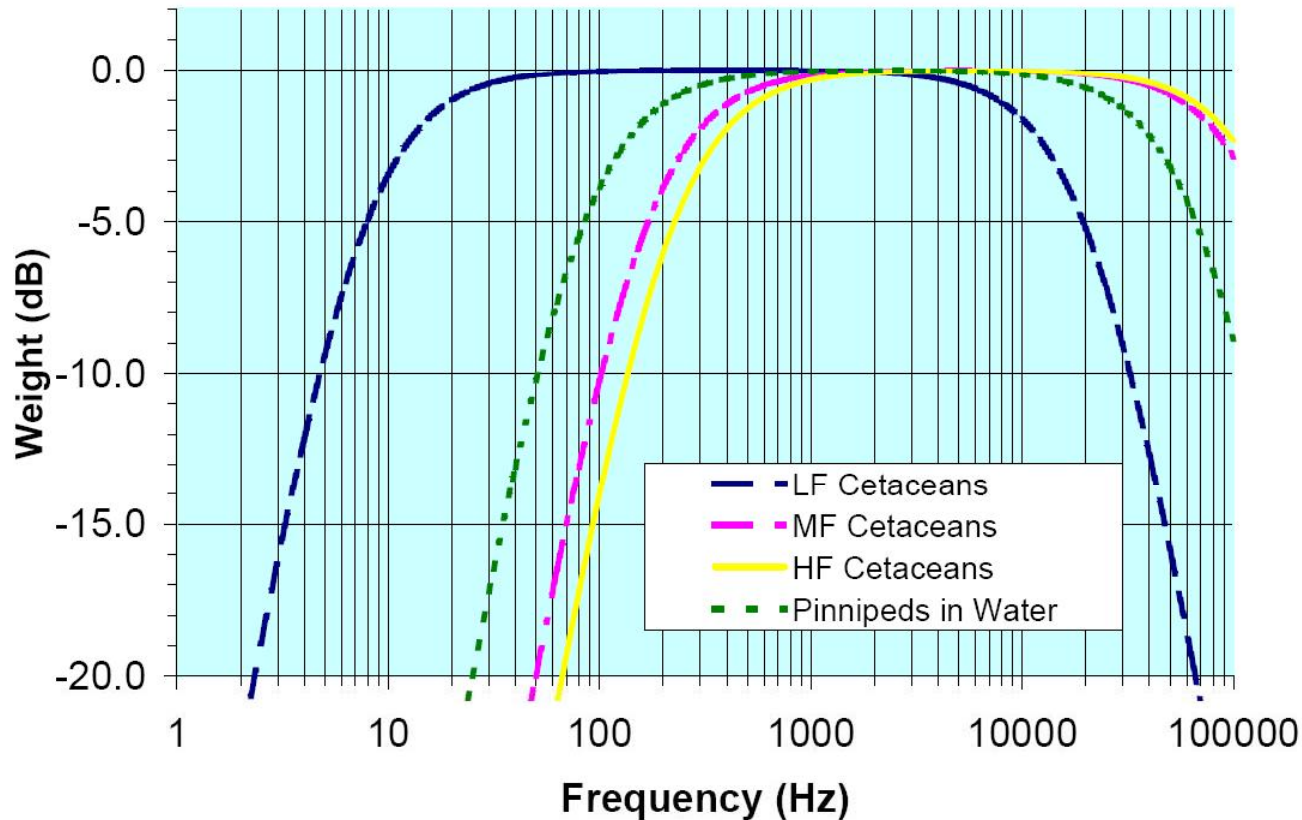

Summary

- **Discussed the Metrics:**
 - Peak Pressure and Peak-Peak pressure
 - RMS pressure
 - Sound Exposure Level (SEL)
 - Cumulative SEL
 - M-Weighted Cumulative SEL
- **Historically the RMS pressure has been used to gauge impacts. We expect a shift toward Cumulative SEL based metrics for future assessments.**

Sound Metrics

Presented by Dr. J. Diebold, L-DEO

ESRF Workshop on Seismic Survey Sound Propagation in the Beaufort Sea
Calgary, 14 July 2009

SEL - RMS comparisons

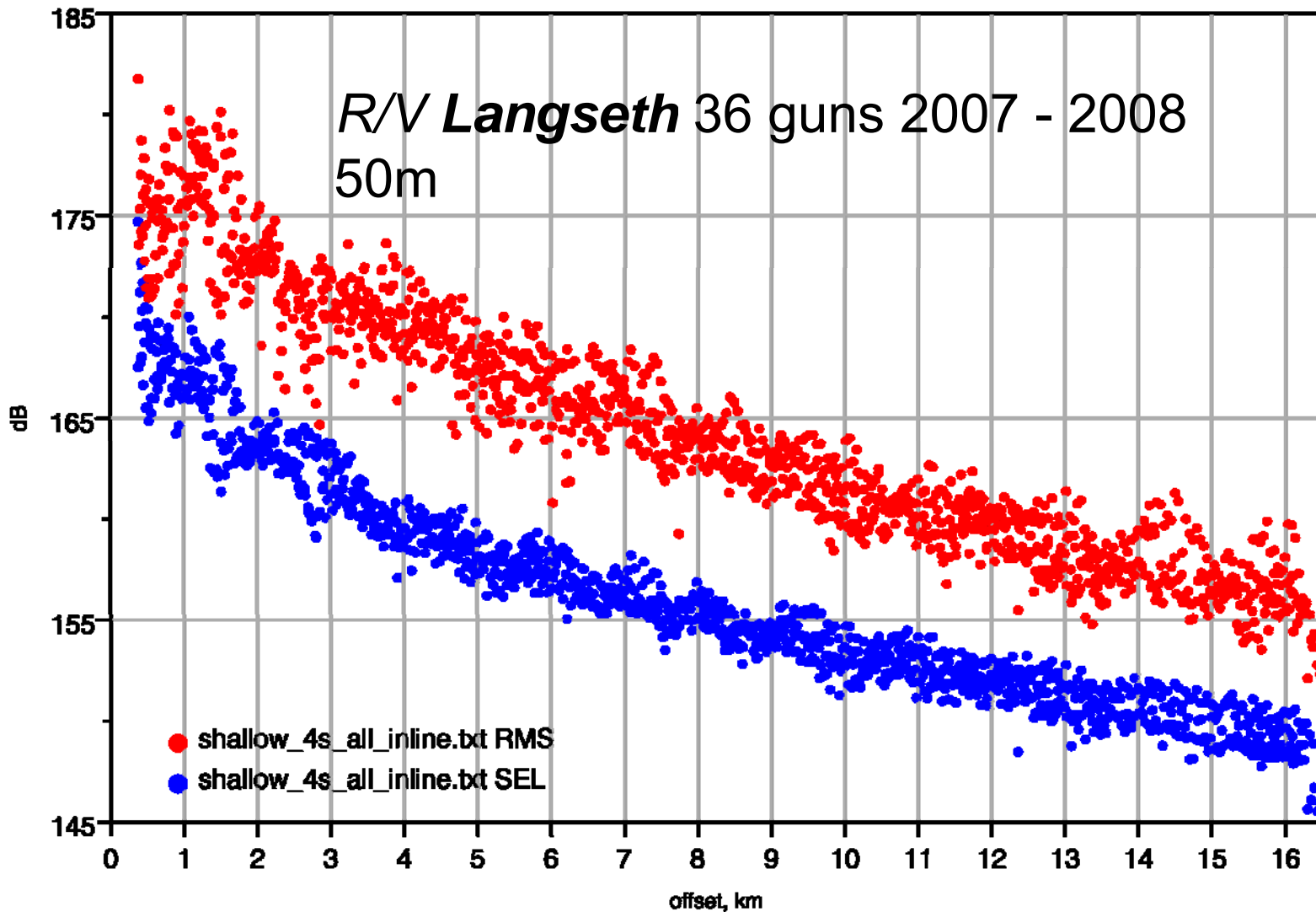

Shallow water - back projected

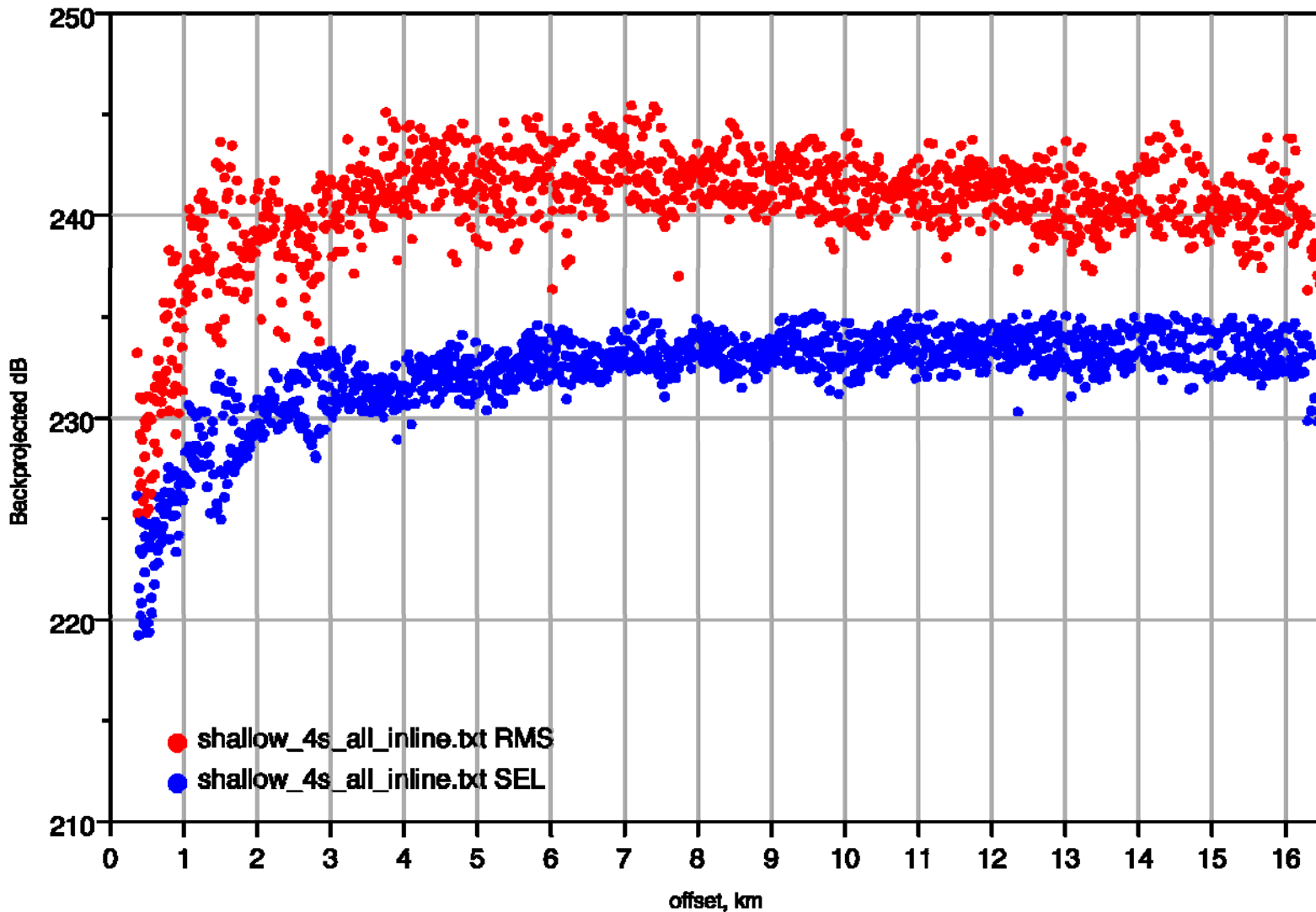

Direct arrival - back projected

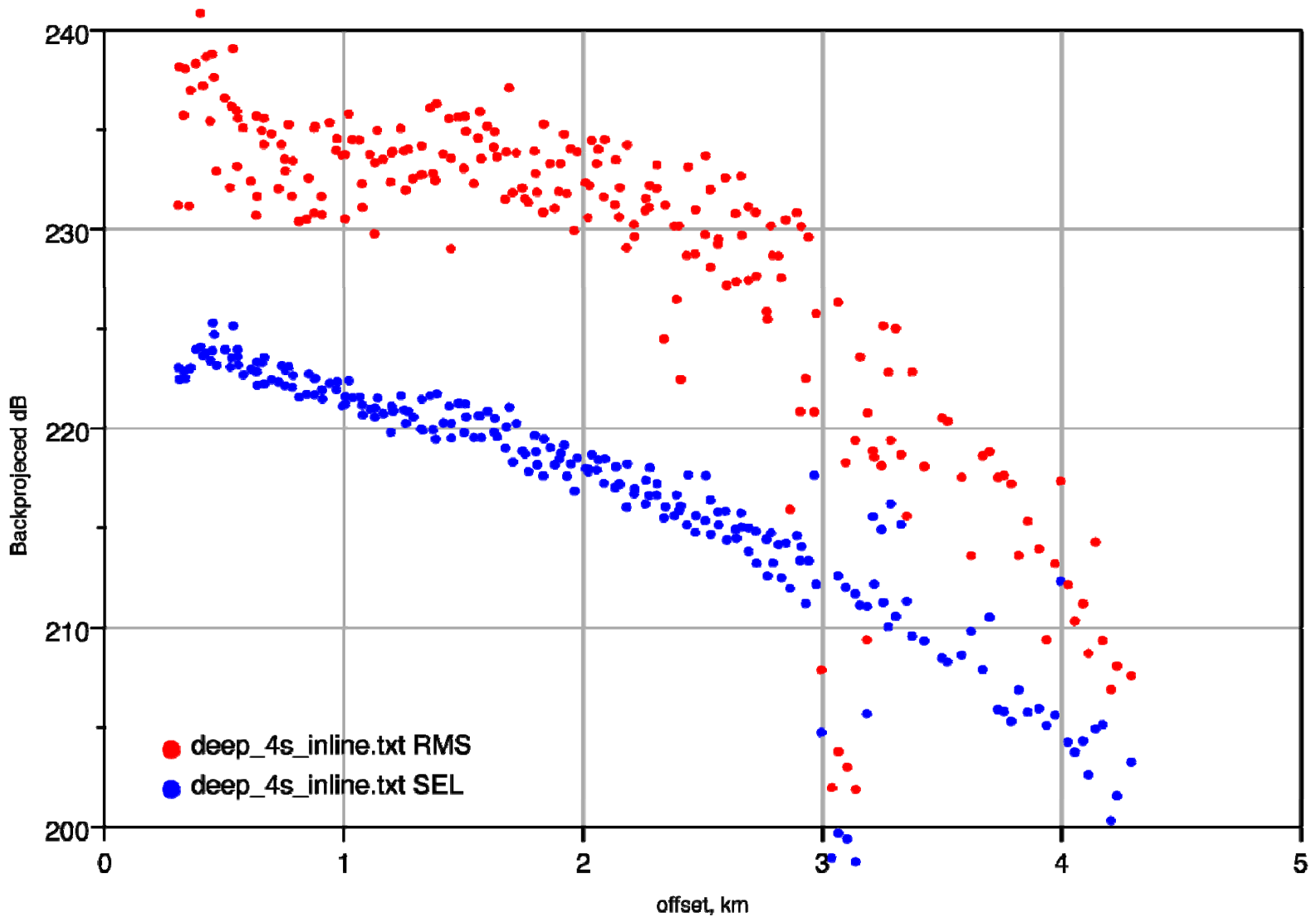

Direct arrival - back projected

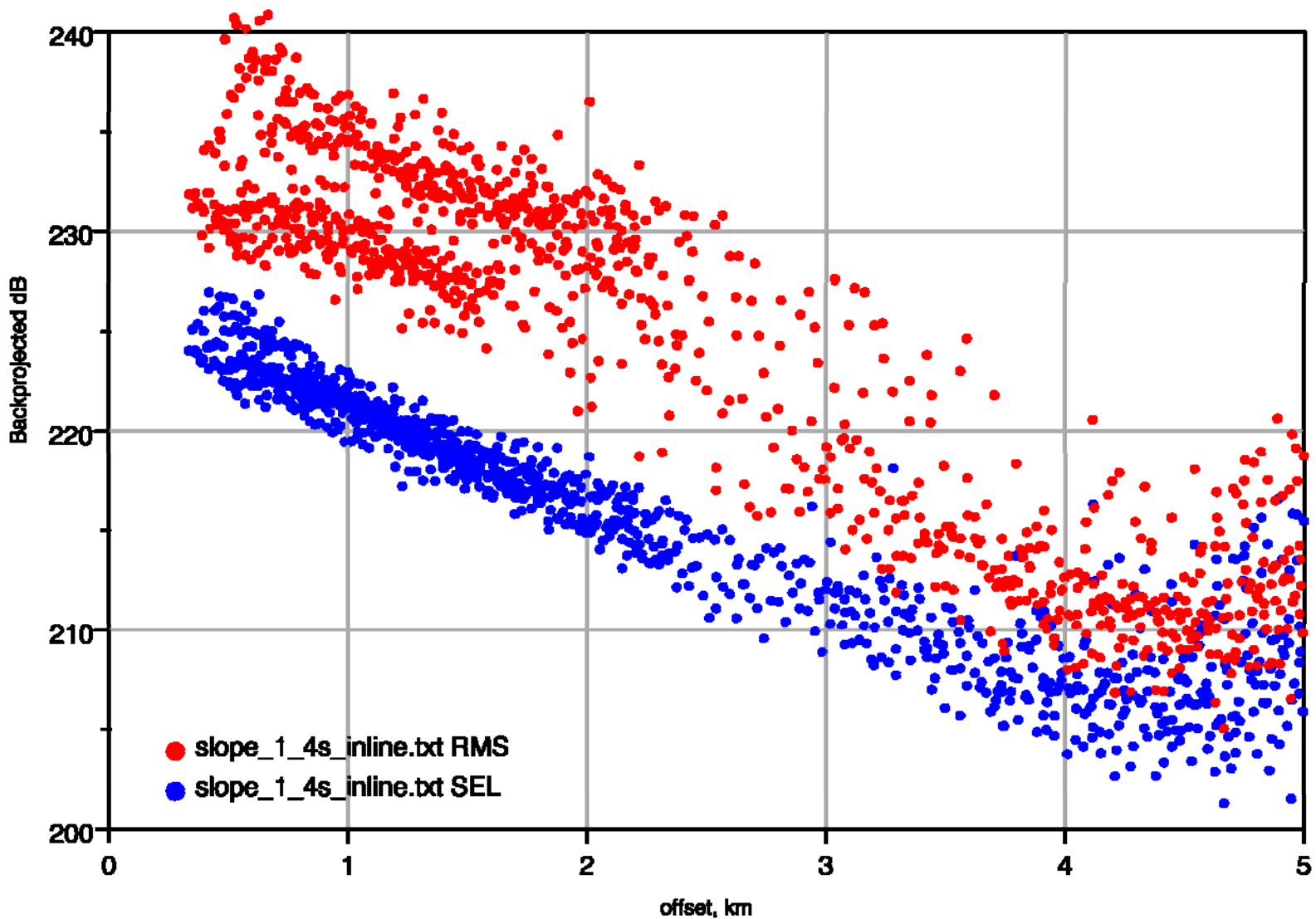

QUANTIFYING MASKING EFFECTS OF SEISMIC SURVEY REVERBERATION OFF THE ALASKAN NORTH SLOPE

*Melania Guerra
Aaron M. Thode
Scripps Institution of Oceanography*

*Susanna Blackwell
Charles Greene Jr.
Greeneridge Sciences Inc.*

*Michael Macrander
Shell Exploration and Production Company*

*ESRF Workshop
Calgary – July 14th, 2009*

[Work supported by Shell Exploration and Production Company]

Overview

- ⦿ Motivation:
 - A desire for a standardized reverberation metric
 - Reverberation is important for determining potential masking effects
 - This is a research topic, not part of official reporting requirements
- ⦿ Definition of reverberation metric
 - Three time scales must be defined
- ⦿ Case study:
 - Measurements from 2008 Beaufort Sea Project
- ⦿ Preliminary thoughts on converting reverberation metric into masking metric

Motivation: How to quantify reverberation?

- Calibrated spectrogram of close-range airgun activity
- ~95% cumulative energy in main pulse (red)
- However, reverb levels persist longer than pulse duration (gray)
- Although small fraction of total energy, reverb still greater than background levels
- How to quantify reverberation levels?
- How to translate into “masking” levels?

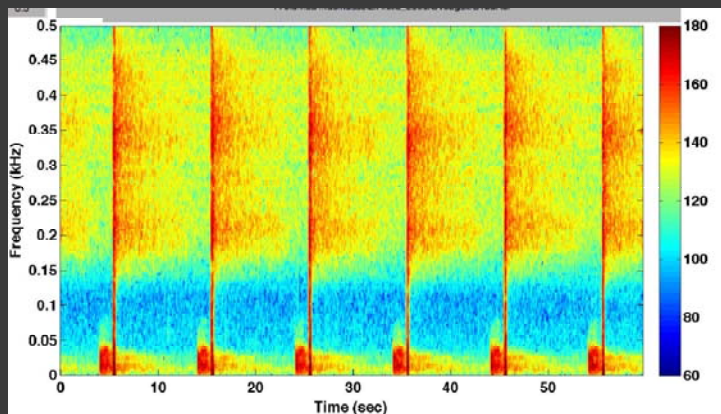

Shallow

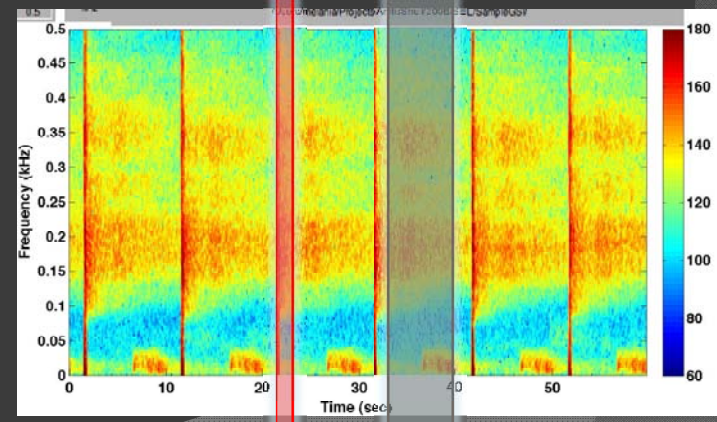

Deep

Dasars S108A0 & S108G0 – Sept/09/2008 03:31:00
Fs = 1000Hz – NFFT = 256 with 75% overlap

Suggested metric for reverberation requires the definition of *three* time scales (instead of one)

- ⊙ An “*energy integration*” time scale Δt_i
 - Same timescale for *rms* or SEL pulse measurement
- ⊙ A “*wide-sense stationary*” time scale Δt_{wss}
 - Time period over which random signal mean and autocorrelation (first and second-order statistical moments) are assumed constant
 - Metric averaged over this time interval to reduce variance
- ⊙ A “*secular, long-term*” time scale Δt_{decim}
 - Time window over which a significant change in source/receiver distance or environmental conditions occur.
 - Pick a minimum level within this time frame to characterize reverberation

“Energy integration” time scale Δt_i
used in the definition of Sound Exposure (SE)

$$SE_i(t) = \int_{T_{i-1}}^{T_i} (p^2(t)) dt = \int_{f_l}^{f_h} (P^2(f)) df$$

- Calculation similar to calculating SEL or *rms* SPL for a transient sound
 - It is a function of frequency band as well
- The difference:
 - Value calculated throughout entire time series, whether a pulse is present or not.
 - Thus need to define an integration time scale that does not rely on a pulse presence
- **We selected a time scale Δt_i** that reflects an estimate of the biologically-relevant energy-integration timescale of a particular species' hearing mechanism
- Case study $\rightarrow \Delta t_i = 1\text{sec}$
 - Simplest scaling, transferable to other cases
 - ~Representative duration of a bowhead whale call

Southall *et al*, 2007
Madsen *et al*, 2005

Search for a “*wide-sense stationary*” timescale Δt_{wss} over which a stochastic acoustic signal’s statistical moments are constant

$$\overline{SE_j} = \frac{1}{N_{samples}} \sum_{j=i}^{i+N_{samples}} SE_j$$

- “Wide-sense stationary” signal \rightarrow ensemble mean and autocorrelation of the signal are invariant at different times throughout interval
- Reduces the variance of the metric
- Case study $\rightarrow \Delta t_{wss} = 2\text{sec}$
 - compromise between the duration of airgun pulse ($\sim 1\text{sec}$) and its periodicity ($\sim 10\text{sec}$)
 - enables a window that does not contain direct airgun pulse.
 - at 50% overlap this averages 3 samples

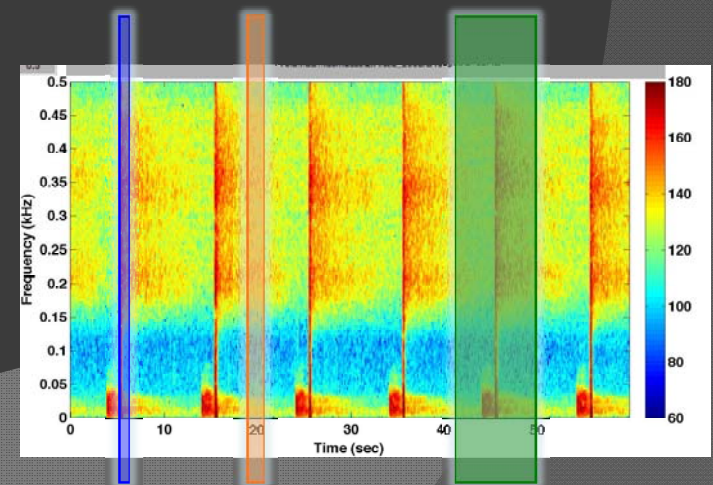

“Secular” timescale Δt_{decim} captures significant long-term changes

- “Secular” = slow varying trend vs short-term oscillatory fluctuations
- Example: Keeling curve – CO₂ content in atmosphere over decades

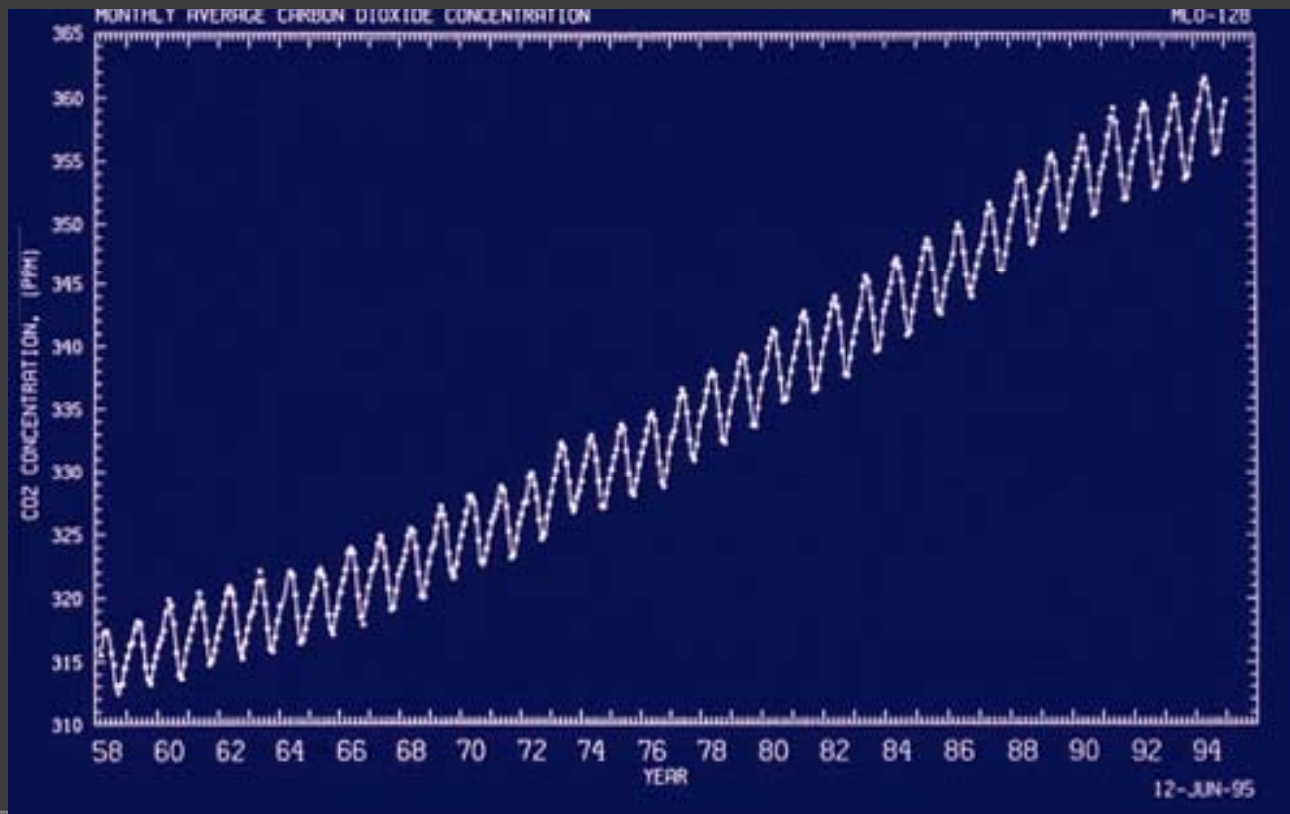

Selecting **minimum value** over several cycles captures long-term trend of curve

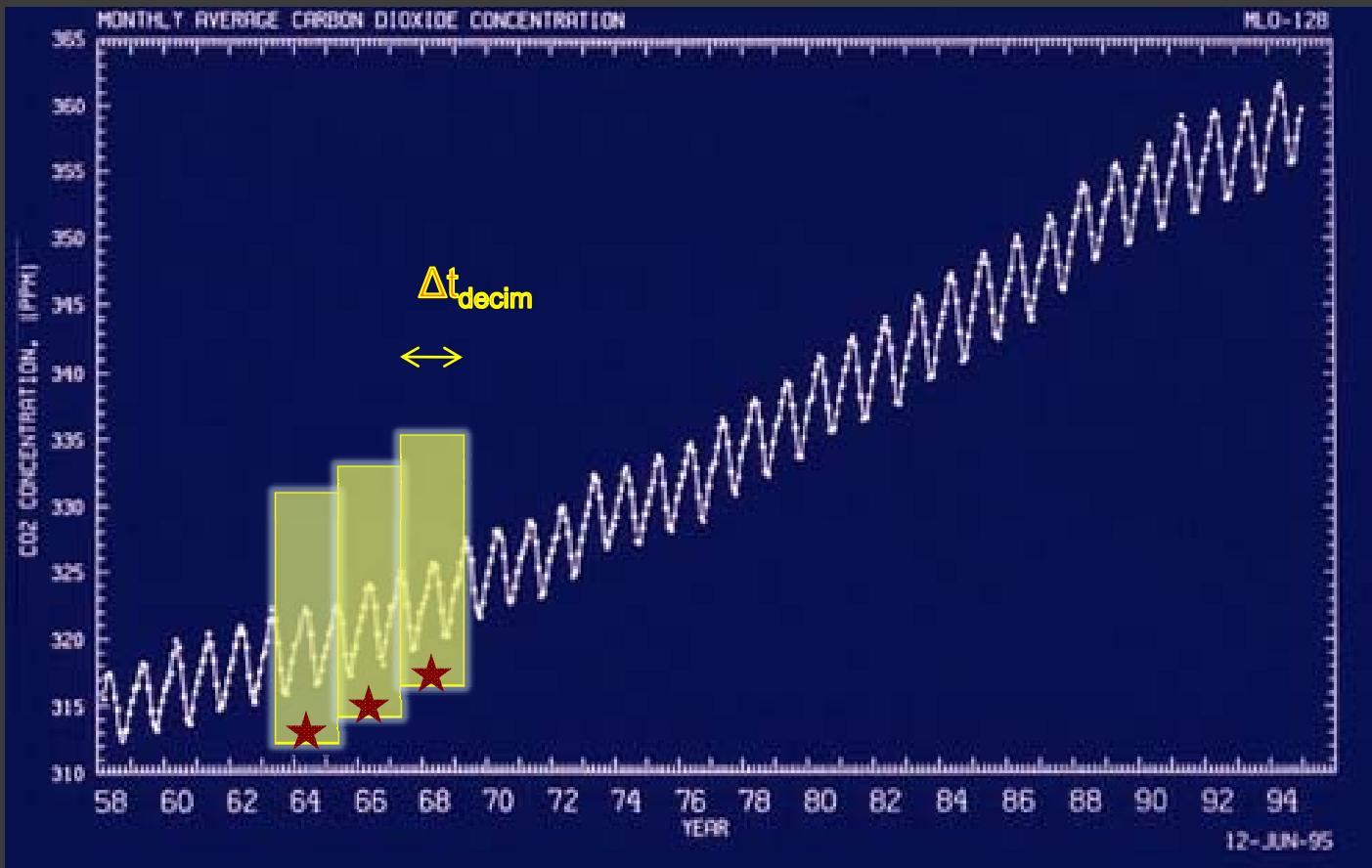

- Median, mean, max values would also capture trend

Selecting **minimum value** of averaged SEL over a time that spans several airgun pulses extracts background/reverberation noise level

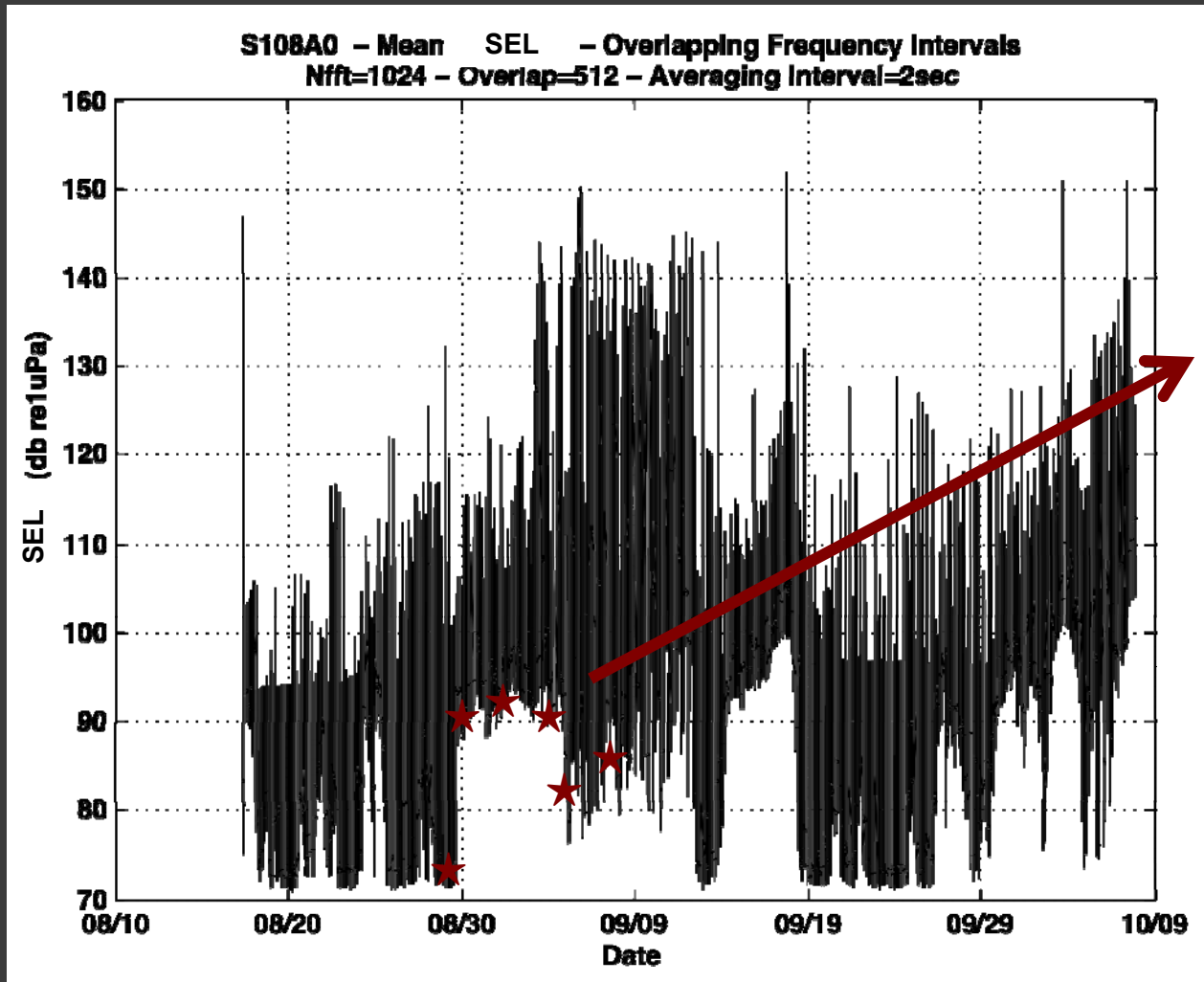

Reverberation
Metric

Case study $\rightarrow \Delta t_{decim} = 1800\text{sec}$

CASE STUDY:

2008 Beaufort Sea Acoustic Project

2008 Beaufort Sea Acoustic Project Site

- **Narrow continental shelf**
 - (30- 60 mi)
- **Several marine mammal species are present in the summer months**
 - Bowhead whale
- **DASAR recording packages @ 1kHz**

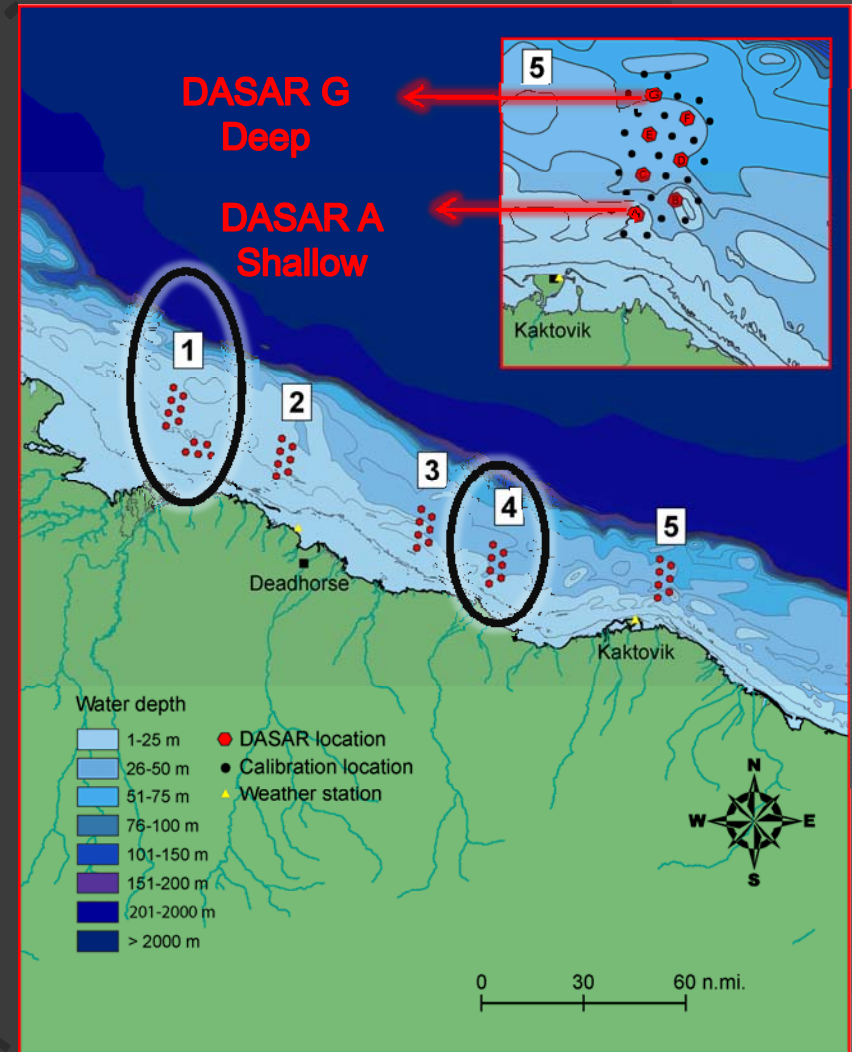

Local seismic activity within DASAR sites

- 2 WesternGeco towed arrays ~275m behind the R/V Gilavar
- 24 airguns ea. – distributed into three sub-arrays – total volume of 1049 in³
- Bolt airguns shot at intervals of 25m (~10sec) - vessel speed ~4-5 knots
- Operated at $P_{\text{air}} = 2000\text{psi}$

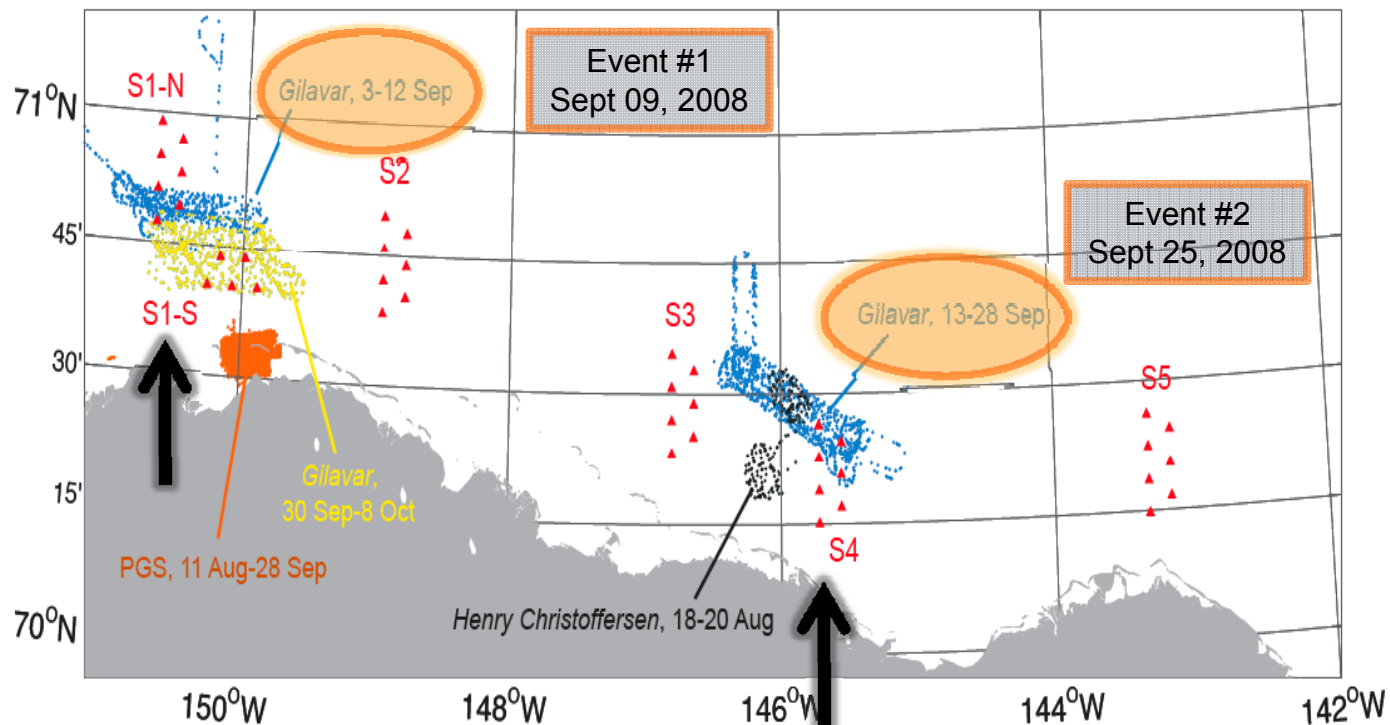

Calibrated airgun spectrograms demonstrate water depth and aspect-dependent reverb behavior

Site 1 G - Shallow

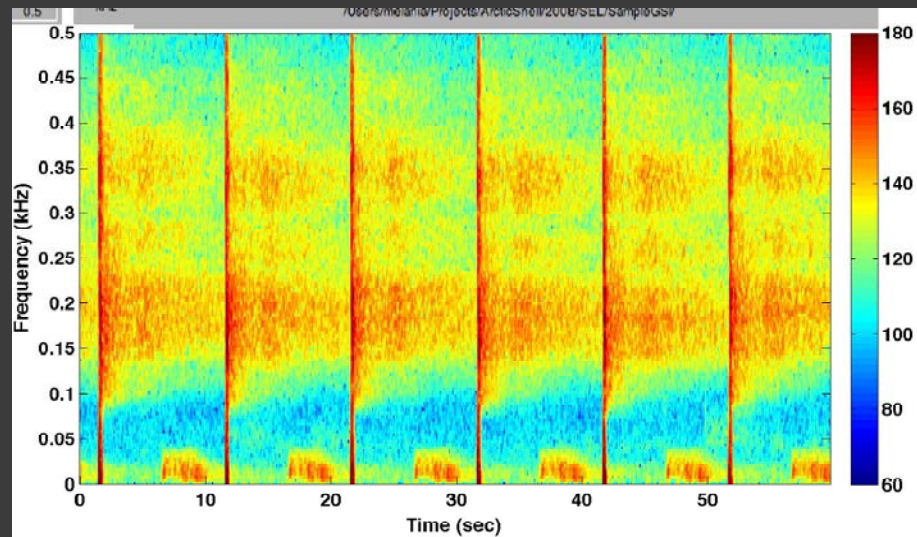

Site 4 G - Deep

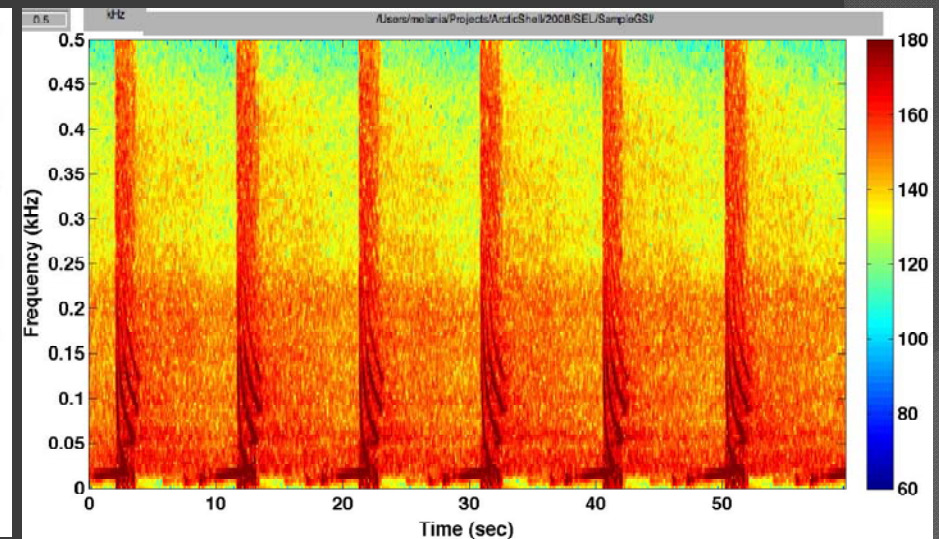

- Differences in reverberation: frequency range, duration and levels

Review of parameters used in case study

- Time scales:

- “*energy integration*” time scale $\Delta t_i = 1\text{sec}$
- “*wide-sense stationary*” time scale $\Delta t_{\text{wss}} = 2\text{sec}$
- “*secular*” time scale $\Delta t_{\text{decim}} = 1800\text{sec}$

- Frequency bands:

- Broadband (10-450Hz)
- Narrow bands (10-110Hz, 110-210Hz, 260-360Hz, 360-460Hz)
- Overlapping bands (10-110Hz; 60-160Hz; 110-210Hz; 160-260Hz; 210-310Hz; 260-360Hz; 310-410Hz; 360-460Hz)

Frequency dependence of reverberation metric

Site 4 A
Shallow

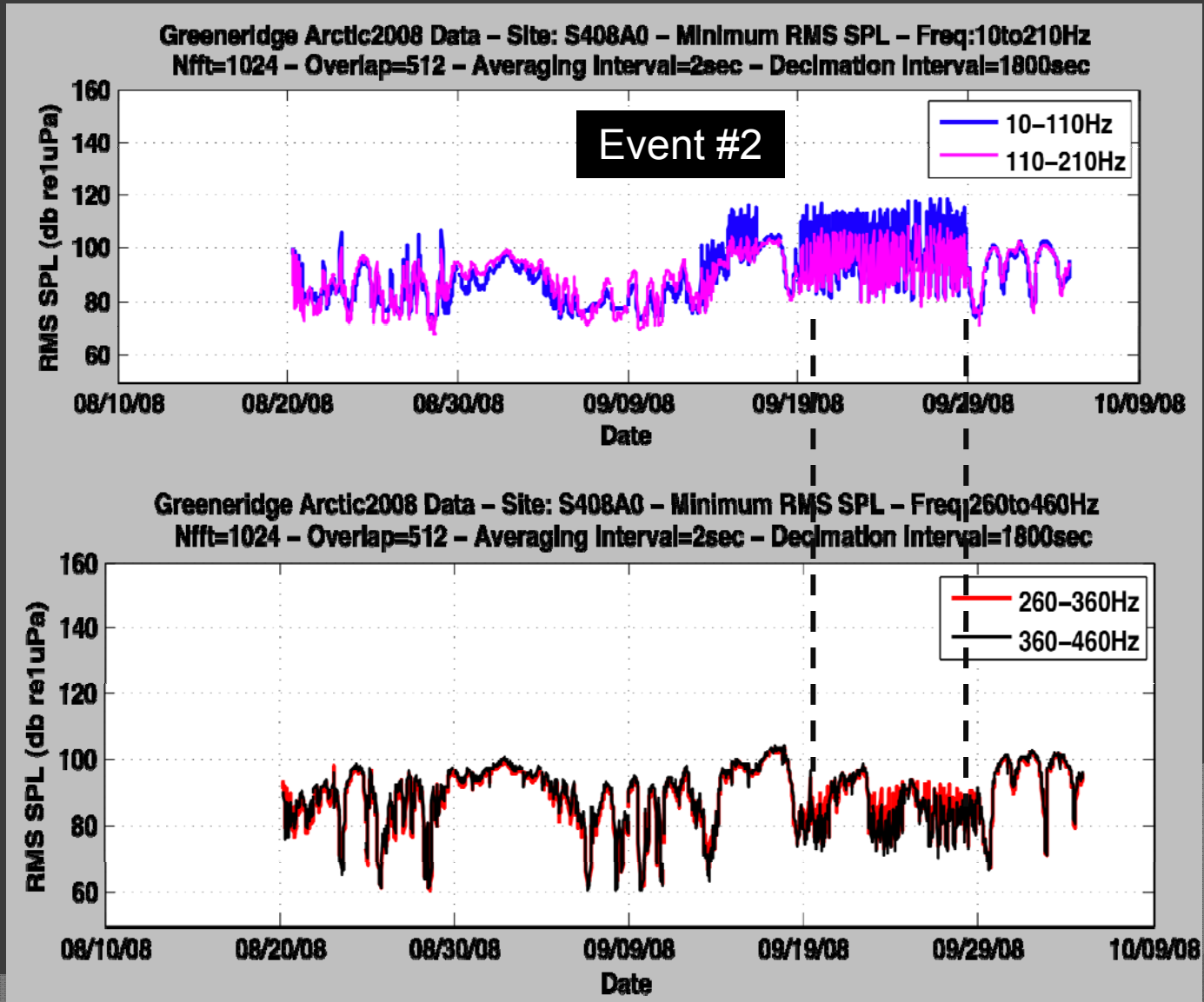

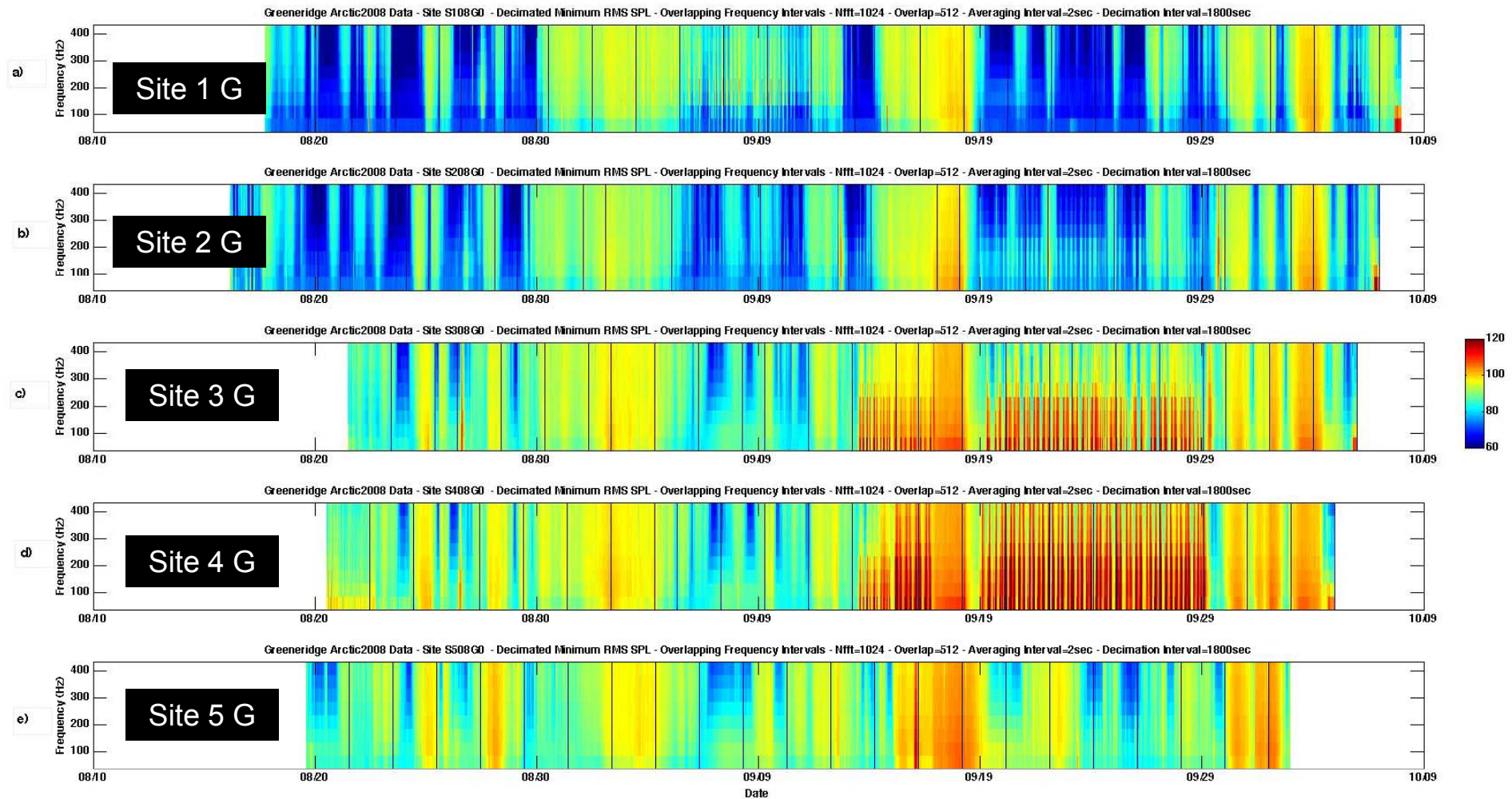

- Time/frequency image of minimum background levels over 30 minute blocks – overlapping frequency bands between 10-450Hz

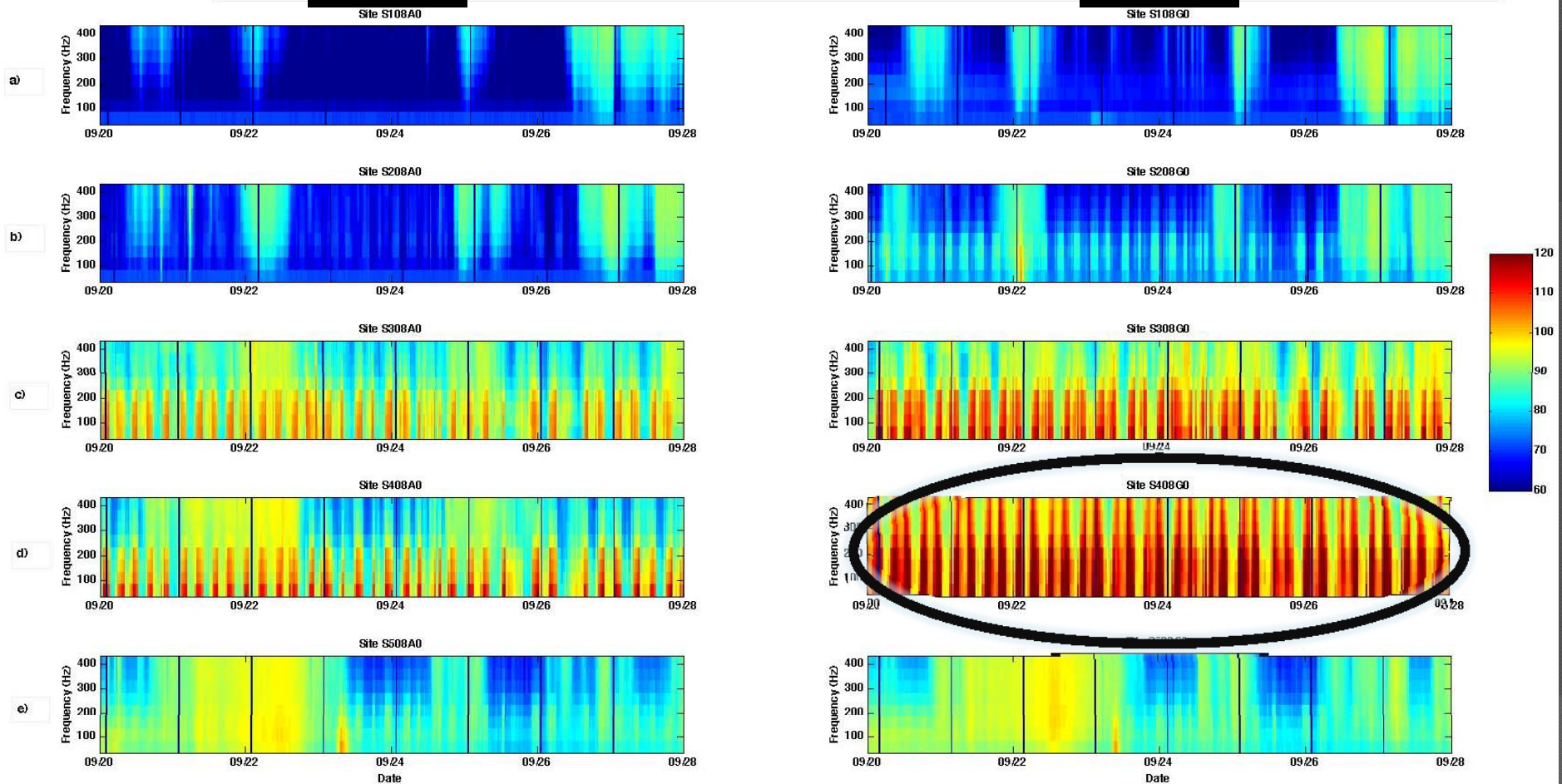

- Deeper locations observe higher reverberation levels
- Reverberation above background at multiple sites, including Site 2
- “Mowing the lawn” effect → range/orientation source dependence

How to convert reverberation metric into quantitative masking?

- Work in progress
- Define a fourth time scale:
 - Assume minimum levels indicate ambient conditions
- Assume ambient noise is primarily driven by wind
 - Wind highly correlated with noise
 - Use wind curves to estimate what ambient noise would be without seismic activity
 - Example: Site 1 minimum noise levels vs. wind speed.

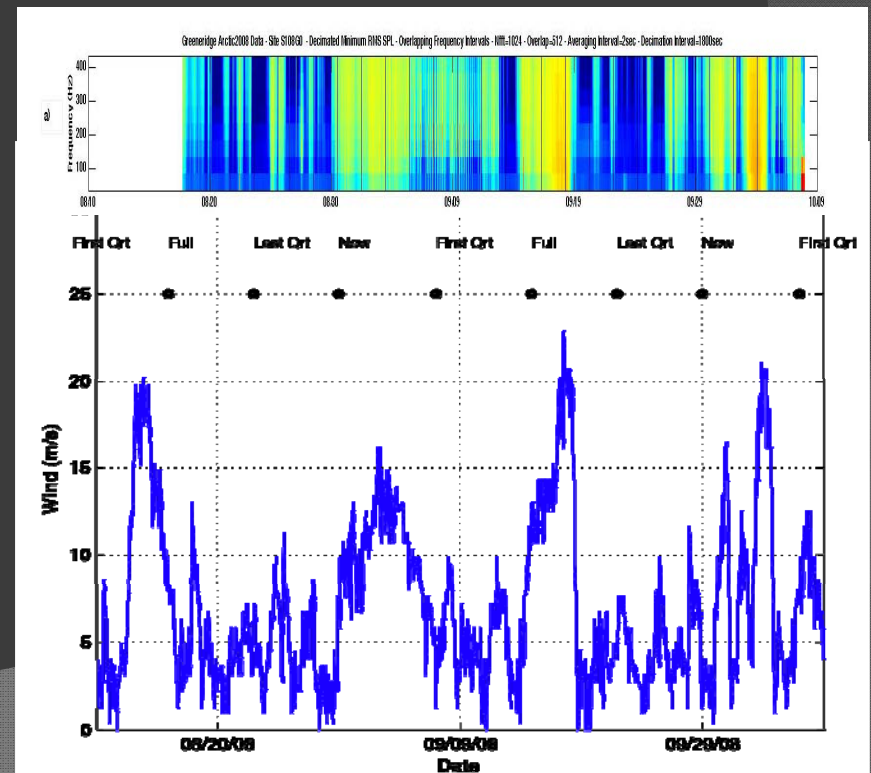

Credit: Susanna Blackwell

Closing remarks

- ⦿ Desire to define a metric for reverberation in impulsive acoustic environments
 - levels are much ↓ than pulse, but ↑ than background
 - reverberant levels are persistent over longer times than pulse itself
- ⦿ Quantifying reverberation requires the designation of three time scales (estimated and/or empirical)
 - “energy integration”
 - “wide-sense stationary”
 - “secular”/long-term trend
- ⦿ Converting ambient noise level to masking still work in progress
 - two possible approaches reviewed
- ⦿ Limitations:
 - fixed to single receiving point, not whale perspective
 - function of site characteristics
 - requires some a priori knowledge for defining multiple time scales

Questions?

Source models for airgun arrays

Presented by Dr. J. Diebold, L-DEO

ESRF Workshop on Seismic Survey Sound Propagation in the Beaufort Sea
Calgary, 14 July 2009

R/V Langseth source arrays

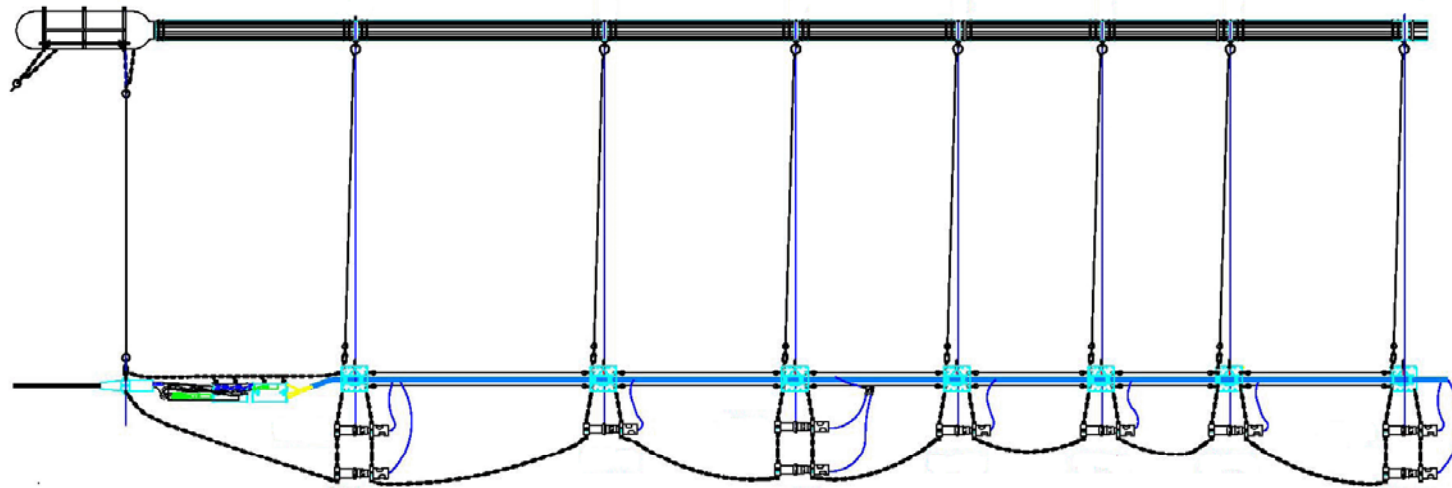

One, two, three or four identical linear subarrays, each with 9 active elements, one ready spare. Individual airgun volumes range between 40 and 360 cu. In.

Deep Water Mitigation Radius

The plotted positions X1, XR and X2 are given by Illustrator. The Radius, plotted at position XR is found by:

$$\text{Radius} = 4000\text{m} + (XR - X1) (6000\text{m} - 4000\text{m}) / (X2 - X1) = 5666\text{m}$$

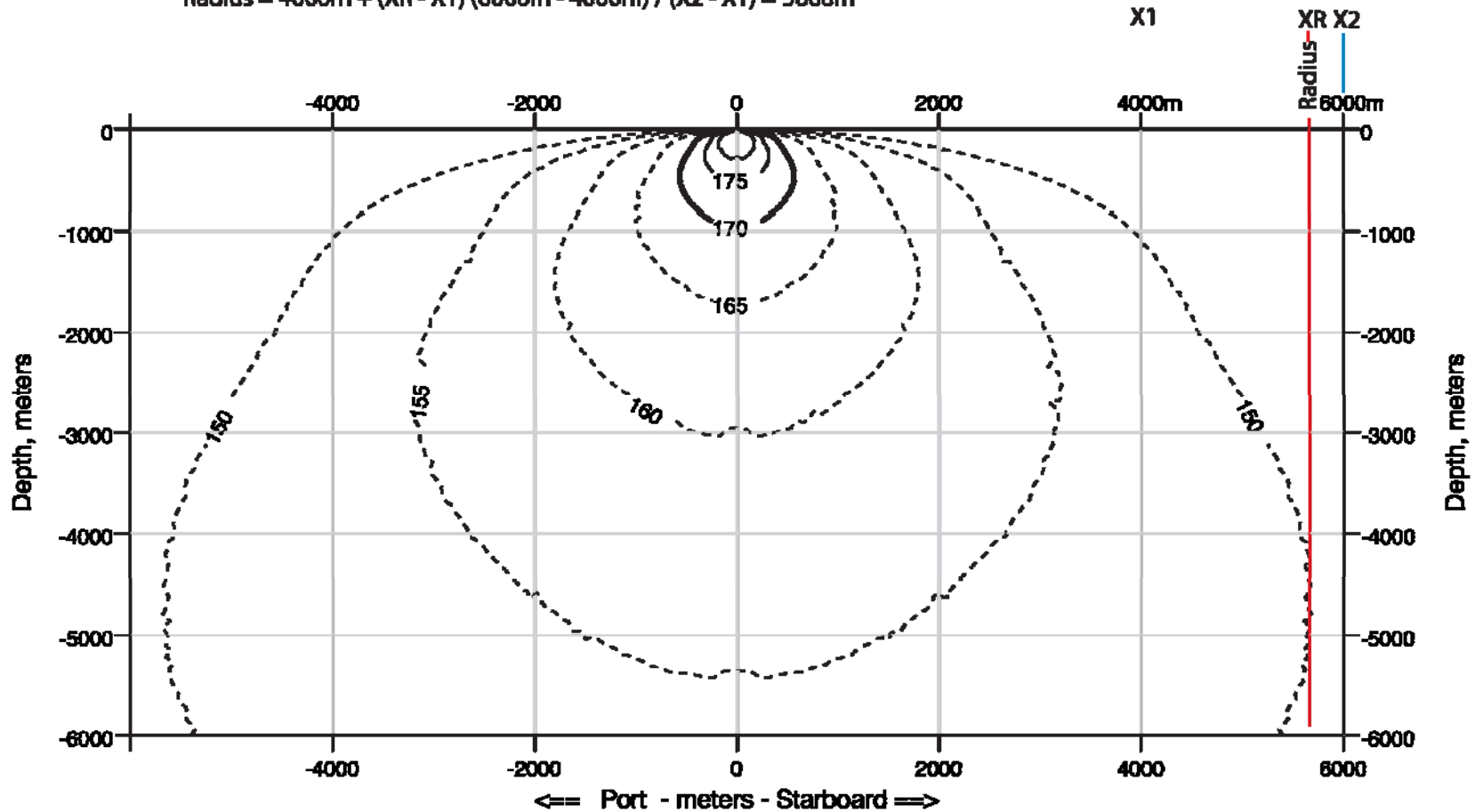

LANGSETH radiuses

array	SEL	Radius
1string 4.5m	170	306
1string 6m	170	352
1string 7.5m	170	383
1string 9m	170	407
1string 4.5m	160	967
1string 6m	160	1112
1string 7.5m	160	1211
1string 9m	160	1291
1string 4.5m	150	3064
1string 6m	150	3516
1string 7.5m	150	3837
1string 9m	150	4072
2string 4.5m	170	373
2string 6m	170	450
2string 7.5m	170	514
2string 9m	170	568
2string 4.5m	160	1177
2string 6m	160	1427
2string 7.5m	160	1632
2string 9m	160	1798
2string 4.5m	150	3724
2string 6m	150	4500
2string 7.5m	150	5150
2string 9m	150	5666

array	SEL	Radius
3string 4.5m	170	442
3string 6m	170	535
3string 7.5m	170	617
3string 9m	170	687
3string 4.5m	160	1412
3string 6m	160	1707
3string 7.5m	160	1966
3string 9m	160	2190
3string 4.5m	150	4514
3string 6m	150	5449
3string 7.5m	150	6271
3string 9m	150	6937
4string 4.5m	170	593
4string 6m	170	719
4string 7.5m	170	833
4string 9m	170	927
4string 4.5m	160	1886
4string 6m	160	2292
4string 7.5m	160	2641
4string 9m	160	2956
4string 4.5m	150	6008
4string 6m	150	7244
4string 7.5m	150	8398
4string 9m	150	9334

PGS source modeling

Chapter 8. Nucleus Technical Manual

Marine Source Modelling (MASOMO)

Method/Algorithm:

Physical thermodynamic modelling which includes effects of clustering and interaction.

Recommended Usage:

- Model, design and evaluate marine seismic arrays.
- Range of modelled guns includes:
 - Bolt 2800 LLX, 1900C, 1900LL, 1900 LLX, 1500C, 1500LL, and 1500 LLX.
 - Bolt Annular Port guns
 - Sleeve guns
 - LLP 7 and 8 inch guns
 - Soderia G-guns, Soderia Mini G-guns
 - Soderia S15, S80 and P400 waterguns

Nucleus creates nearfield signatures

Notional source signatures : 1string_6m_array

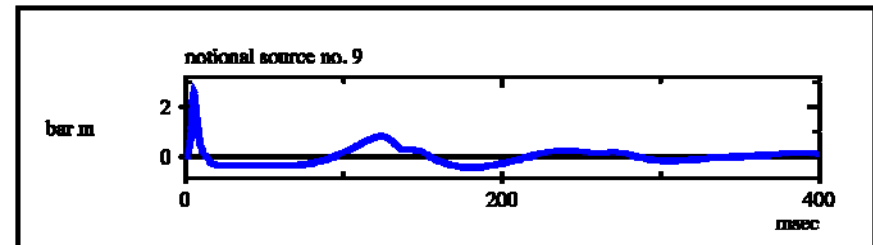
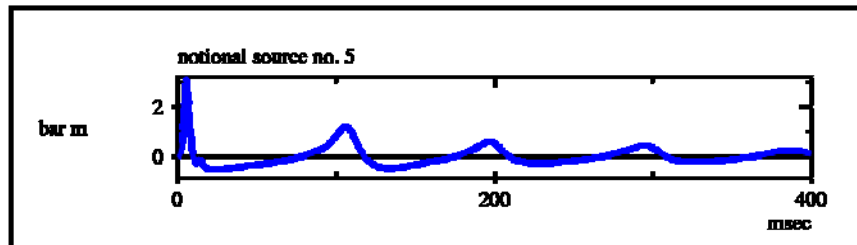
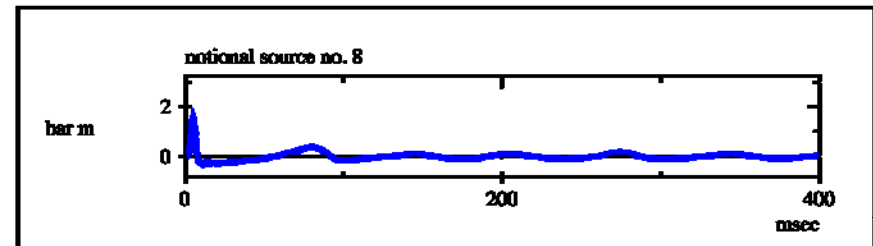
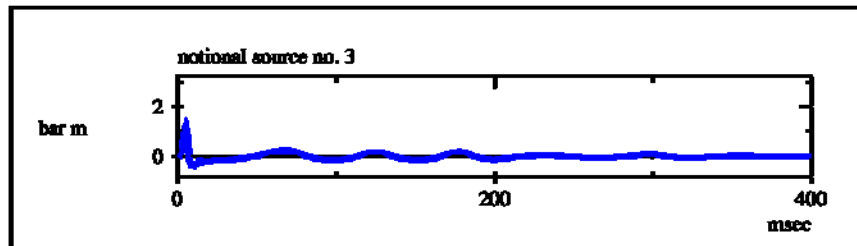
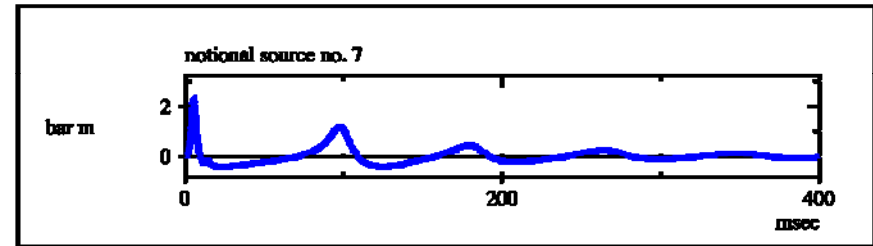
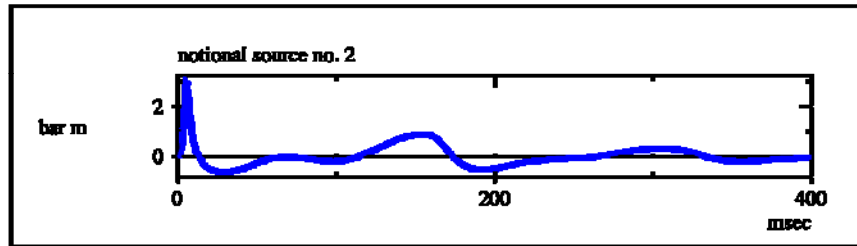
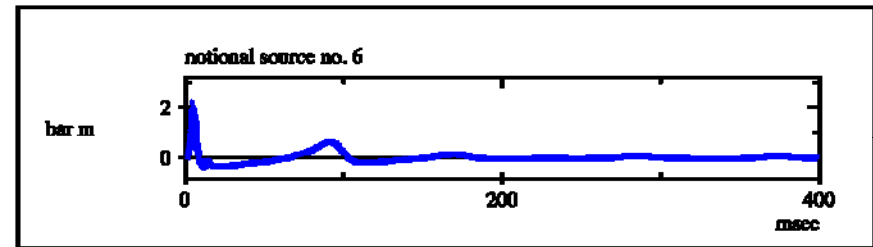
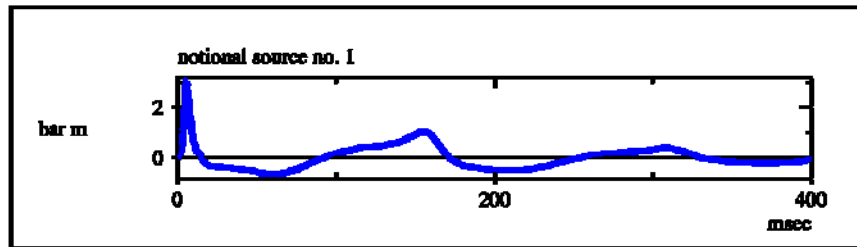

Langseth single string

Array effects - no ghosting

Here, all the airguns in a marine seismic source array unrealistically occupy the same spot in an infinite, homogeneous medium. Thus, the array is omni-directional; the exact relationships previously described hold true, and life is simple. The signal at the right is typical of a tuned airgun array as measured in the “near field,” and the negative peak is small.

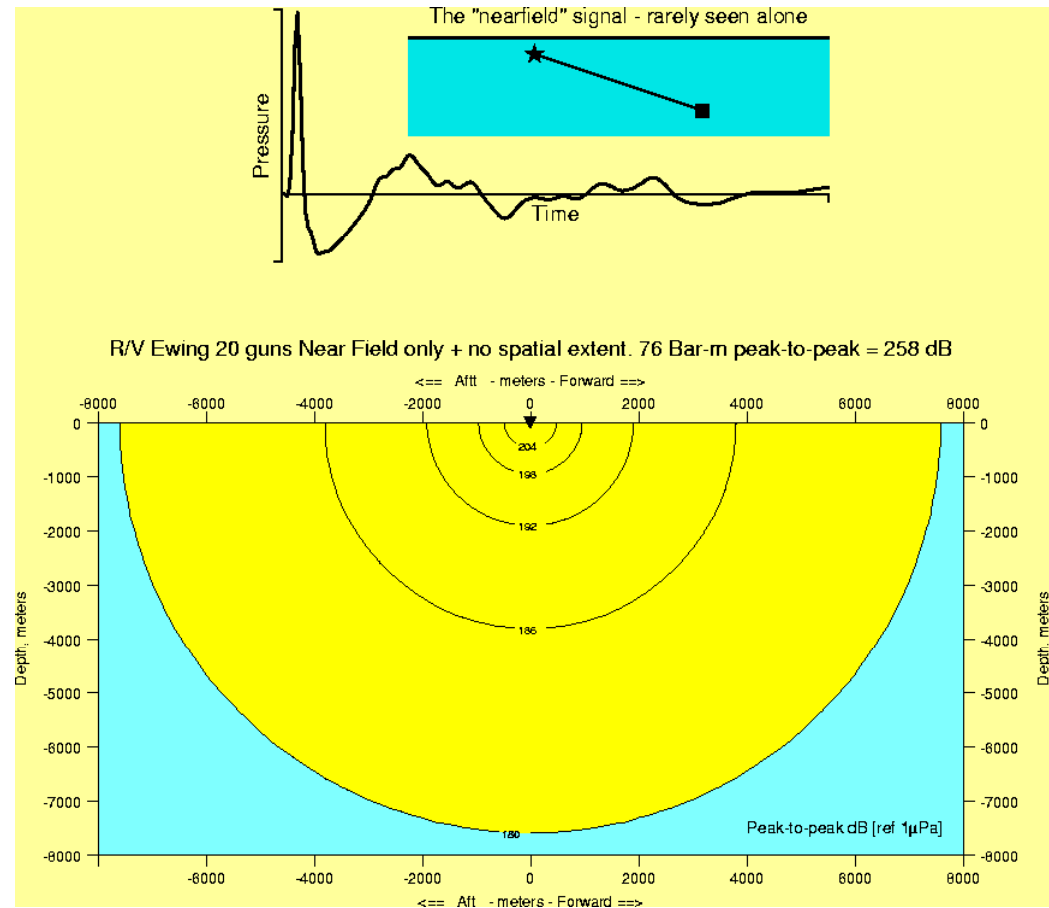

John Diebold, L-DEO

Array Directivity

Any multi-element marine seismic source array has spatial extent, and is therefore “directional” in its output. The near field beam pattern of the R/V *EWING* 20-airgun array in the athwartships (port – starboard) direction is significantly compressed. The specified 262 dB source level is never actually attained.

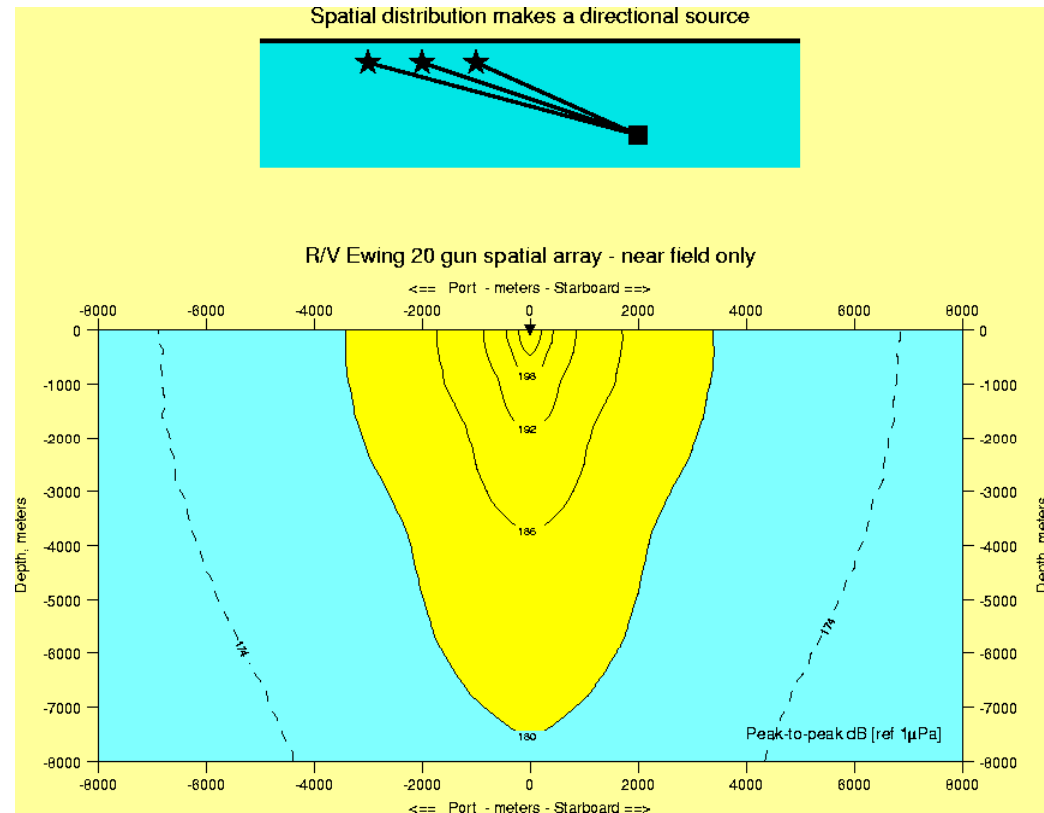

John Diebold, L-DEO

Array Directivity (2)

The R/V *EWING* 20-airgun array is wider than it is long, so that its directivity is less marked in the fore-and-aft, or along-track direction. Since this represents the worst case for mammal mitigation, we will use this orientation for the figures that follow.

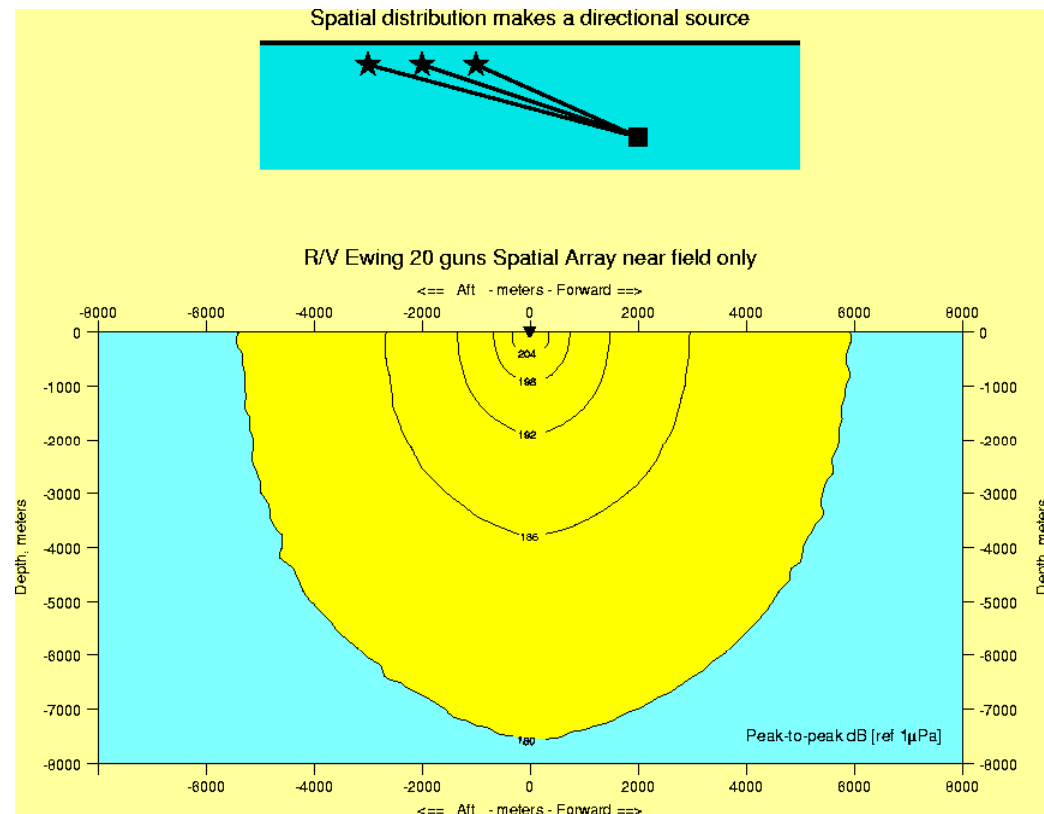

John Diebold, L-DEO

The Free Surface and Ghosting

Ships sail not in an infinite medium but on the surface of the sea. This surface is an excellent reflector of sound, but returns a negative version of the primary signal. At shallow grazing angles, this negative reflection cancels much of the primary energy.

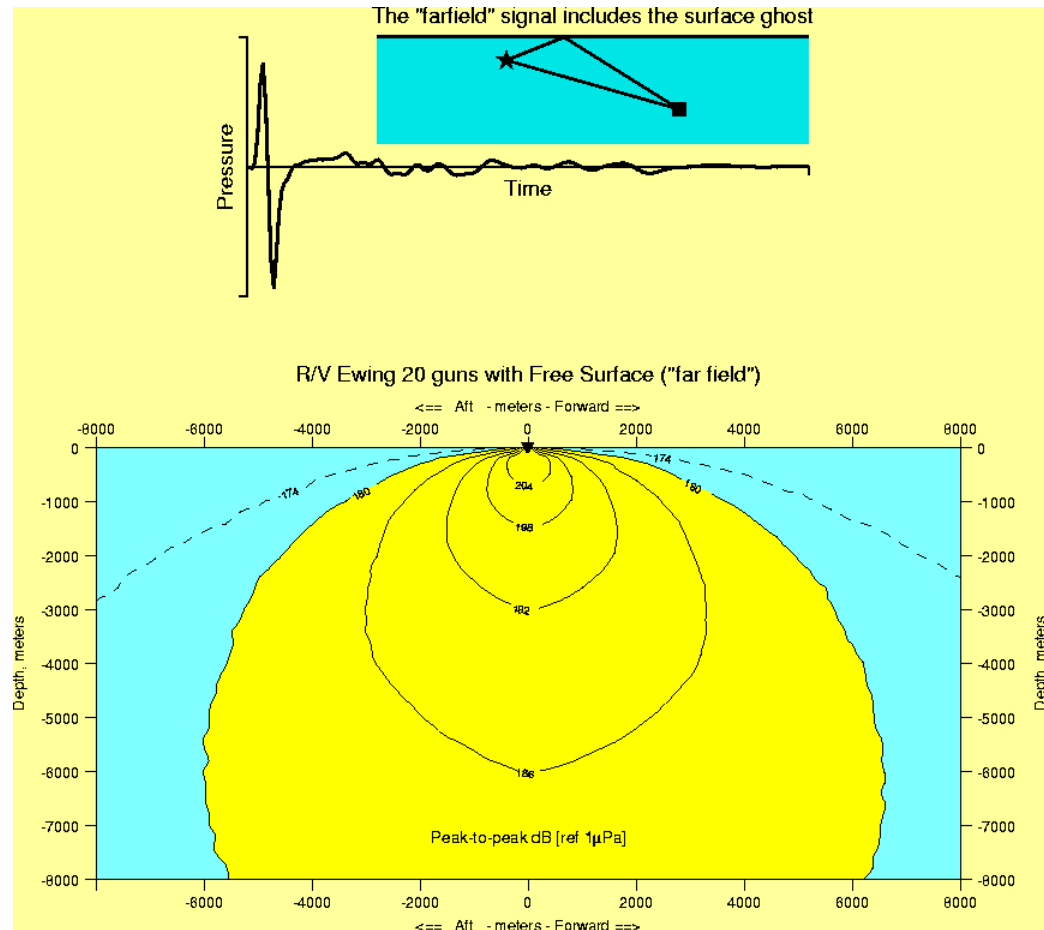

John Diebold, L-DEO

Procedure summary

- Define the array in volume, type and X, Y, Z coordinates
- Model near field signatures
- Define a mesh in 1,2 or 3 dimensions
- Create the signal for each mesh point; for each element:
 - travelttime and distance; scale and shift
 - ditto for surface ghost pathway
 - sum results
- Determine metrics for the summed signal
- Contour the mesh
- Determine Radiuses from contours.

Advantages - Disadvantages

Time domain - easy metrics

Full array geometry

Good for directivity analysis

Publicly available (\$\$ to PGS)

Homogeneous water column

No bottom interaction

Frequency limited

Signal Metrics

Published studies measure sound levels in terms of root-mean-square or RMS. While this measurement is a natural one for signals of long duration, they are less successful in characterizing impulsive seismic signatures. Automatic calculation of RMS directly from signals can produce variable results.

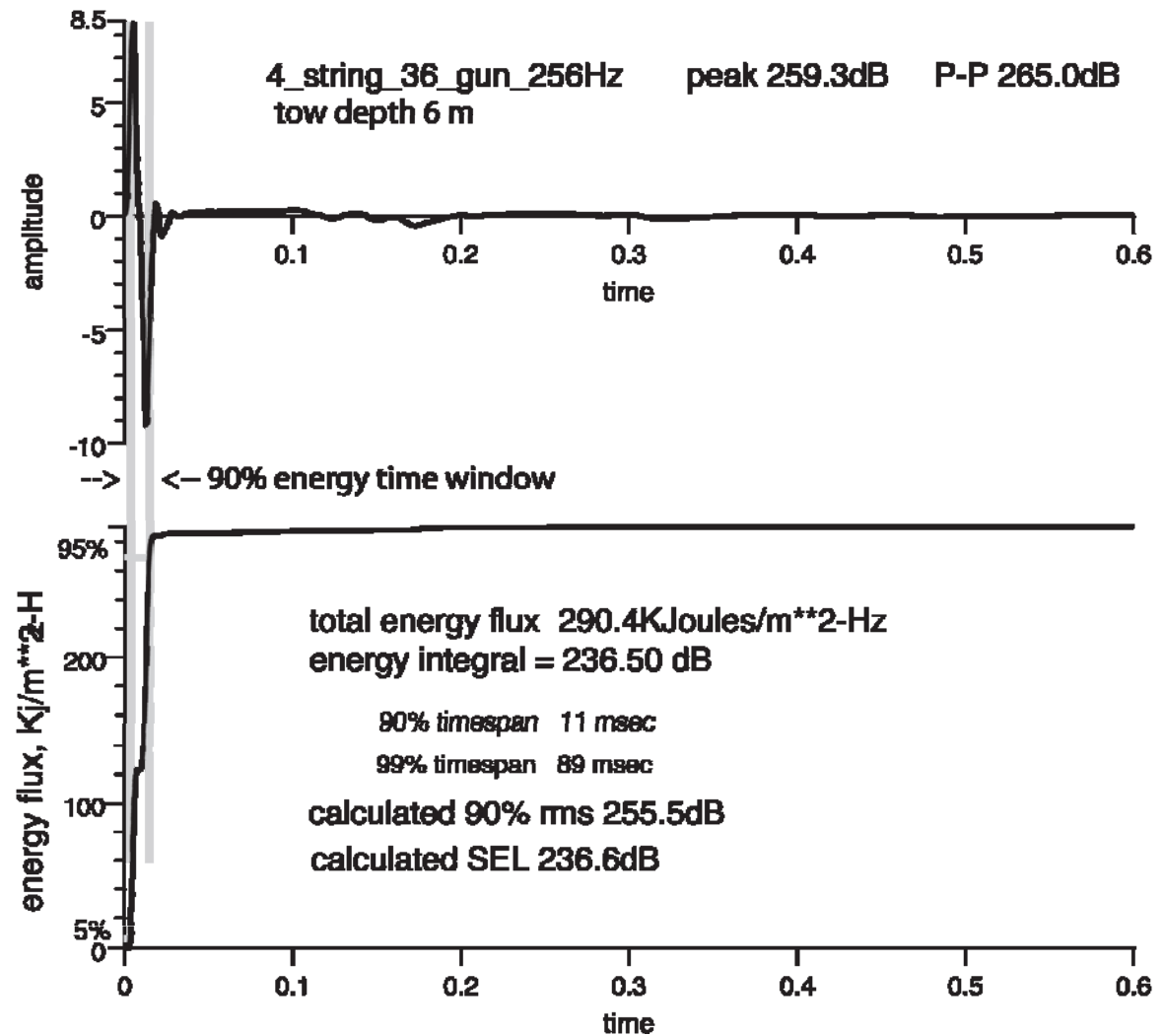

John Diebold, L-DEO

CSEL for models

$$\text{CSEL} = \text{RL} + 10 \cdot \log_{10}(N)$$

Where RL is received level of a single shot and N is the number of shots.

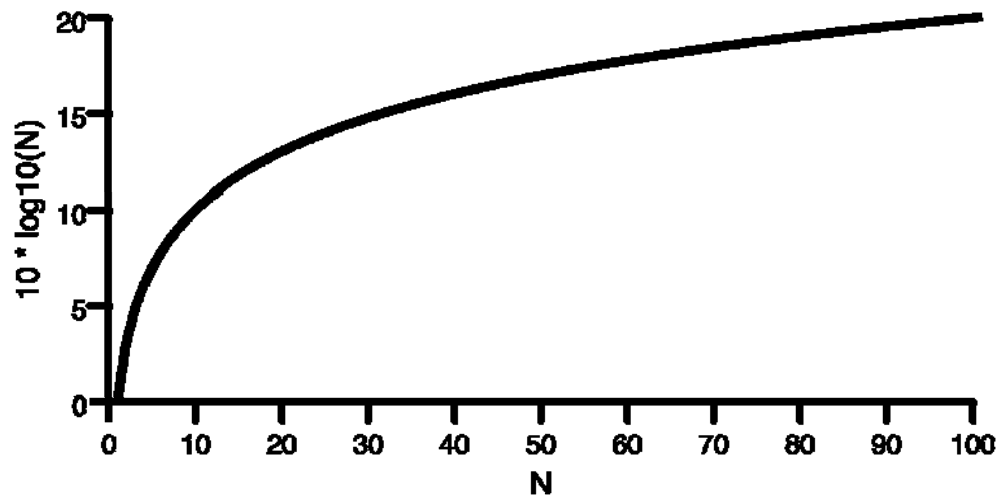

Signal Metrics (2)

In the spectral domain, signal energy is decomposed according to frequency content. Geophysicists generally display energy spectra with a linear frequency scale [top] while biologists prefer the 1/3 octave display [bottom.] In either case, the total integrated energy should be equal to that obtained from the signal in the time domain.

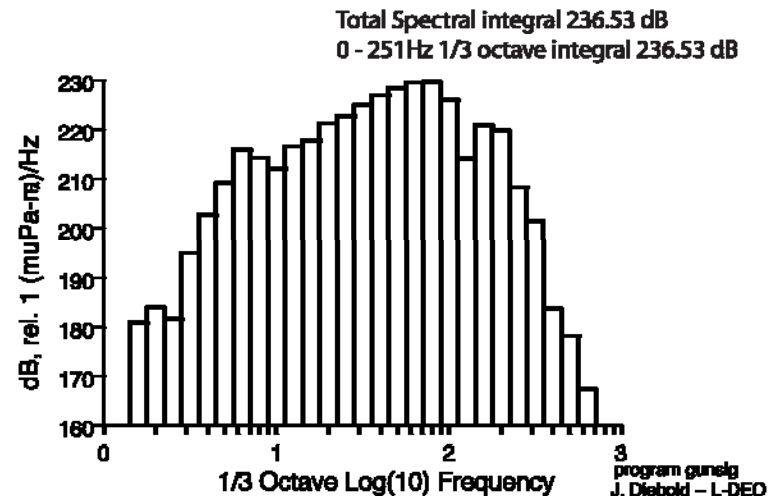
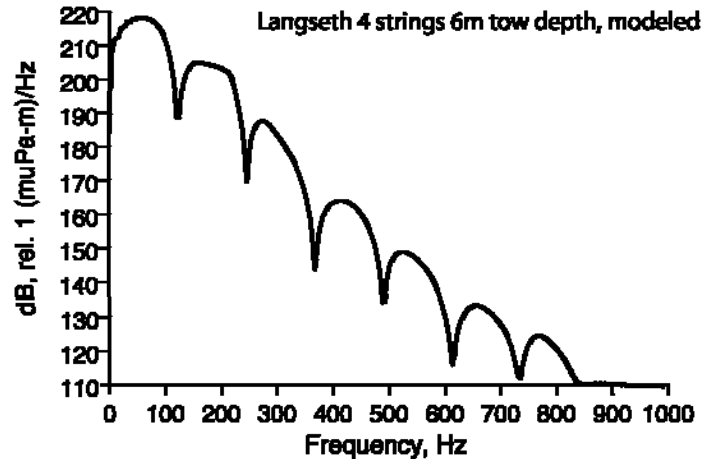

90%RMS: the penalty for array
tuning

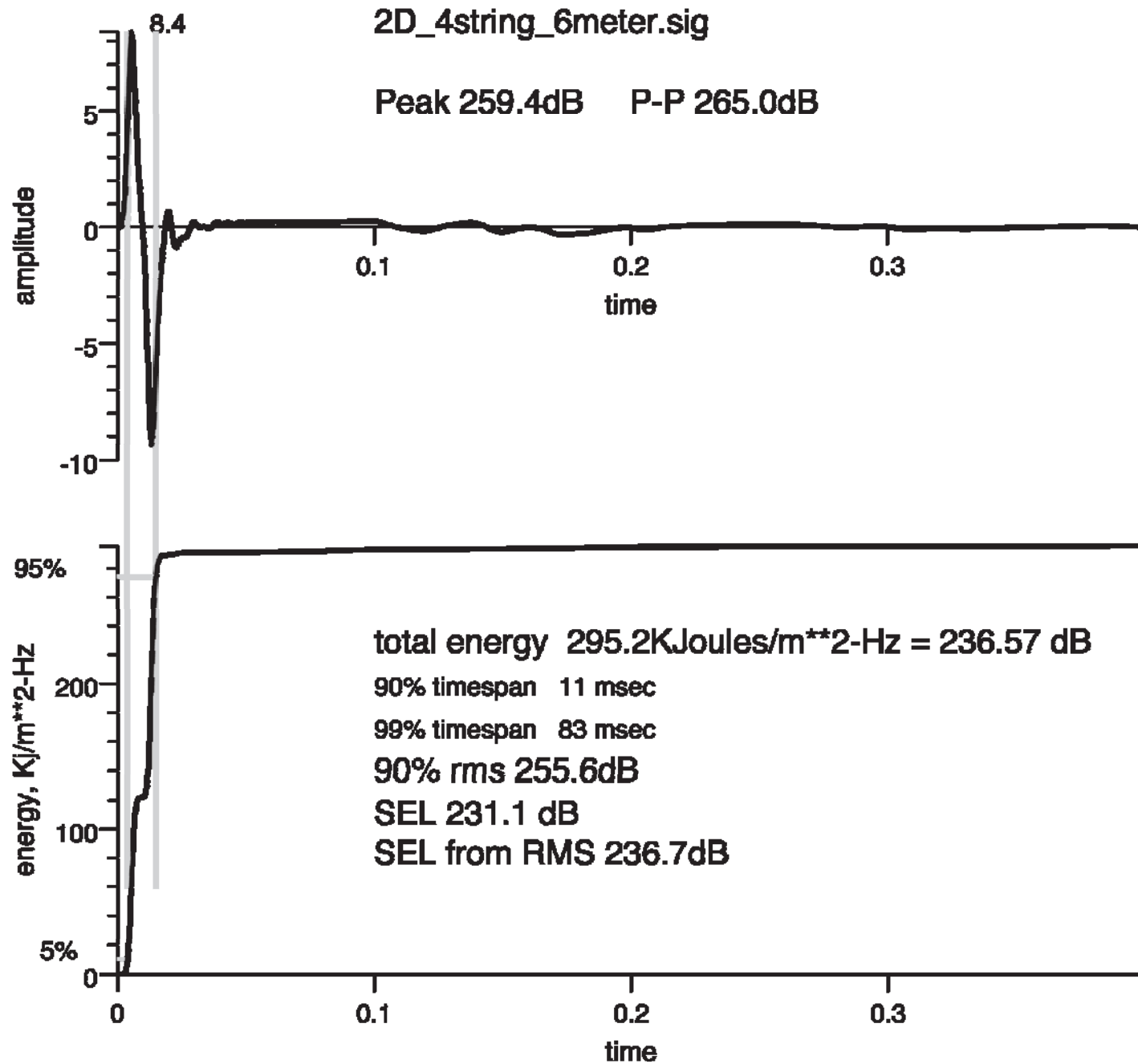

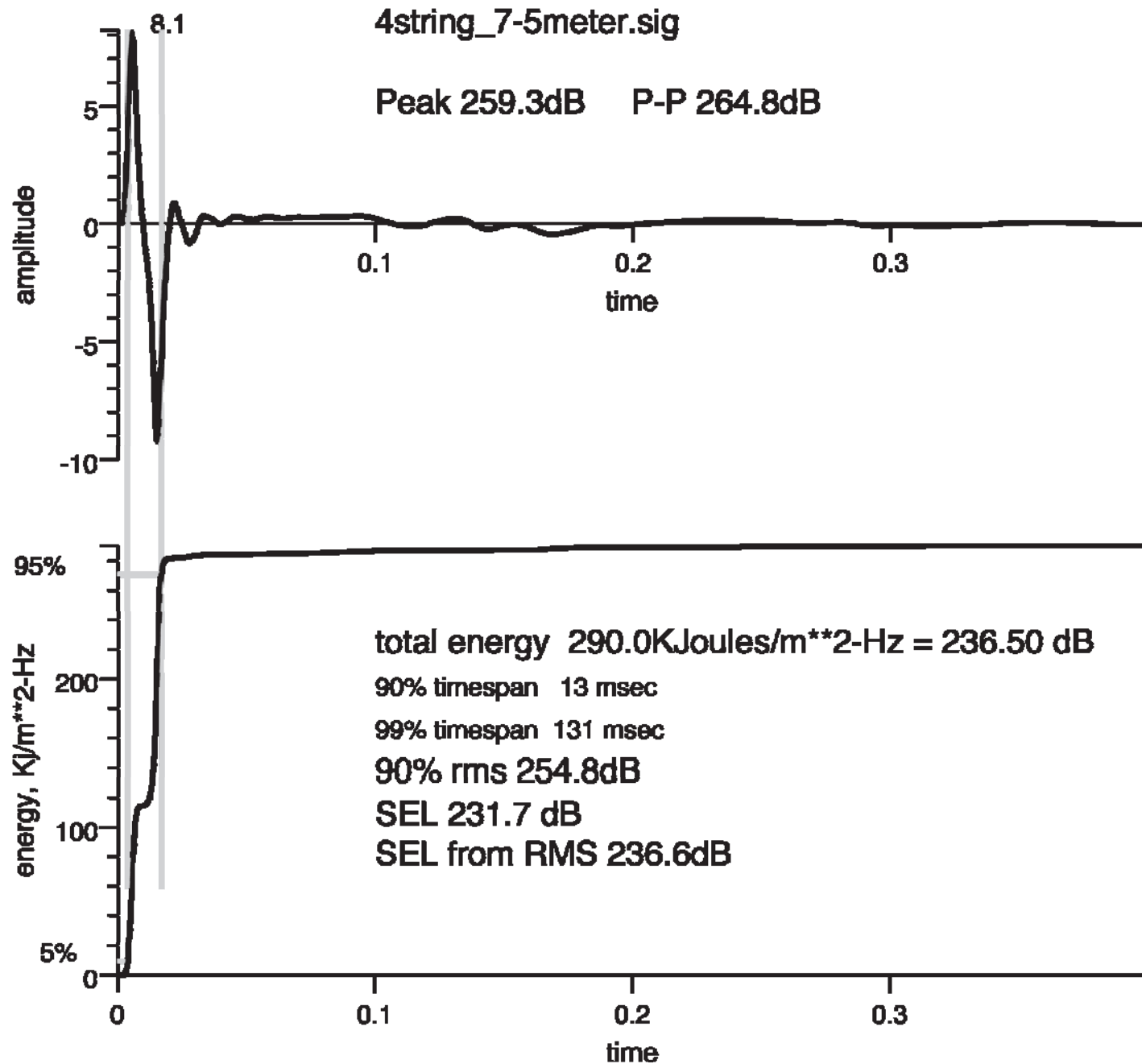

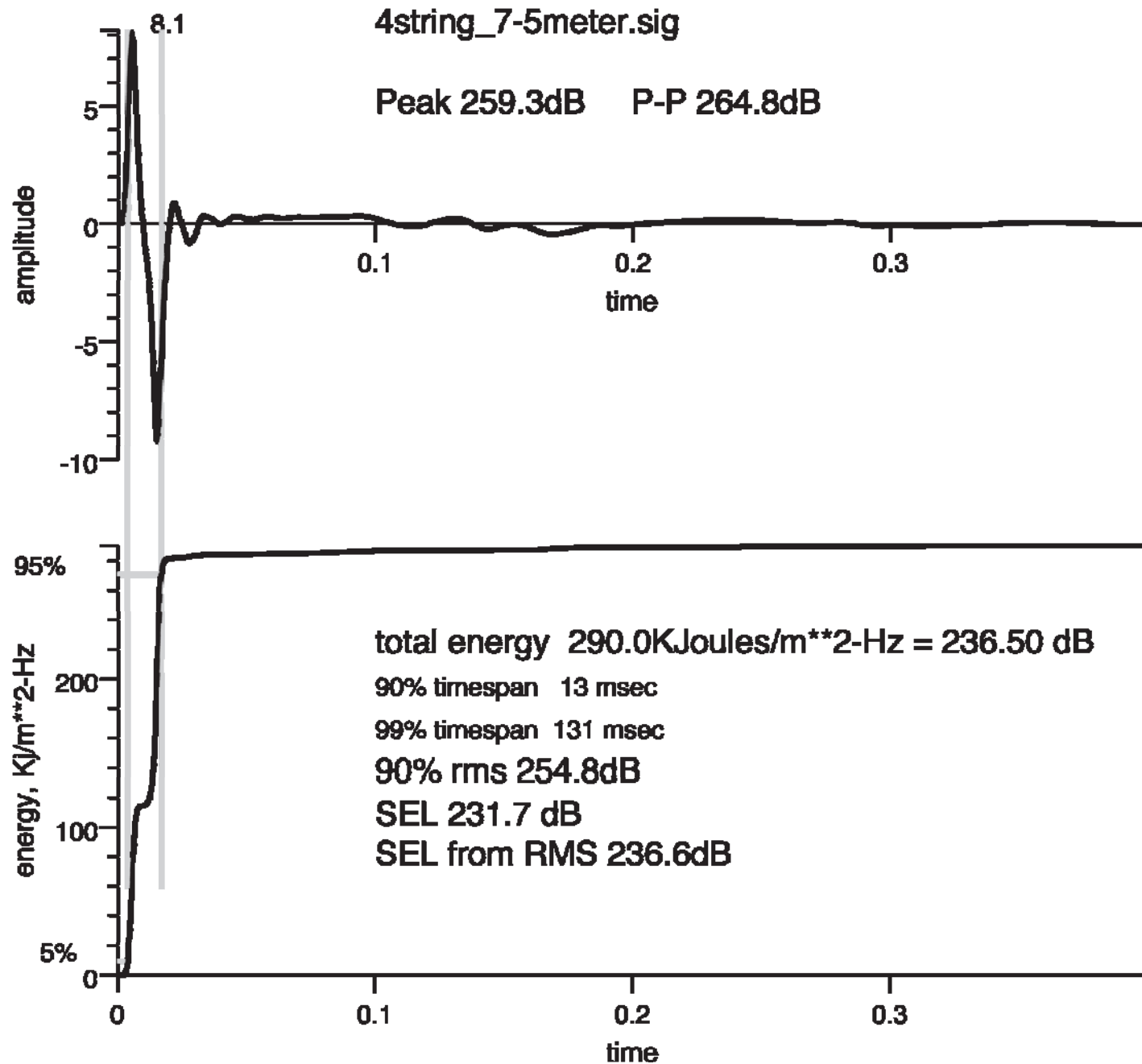

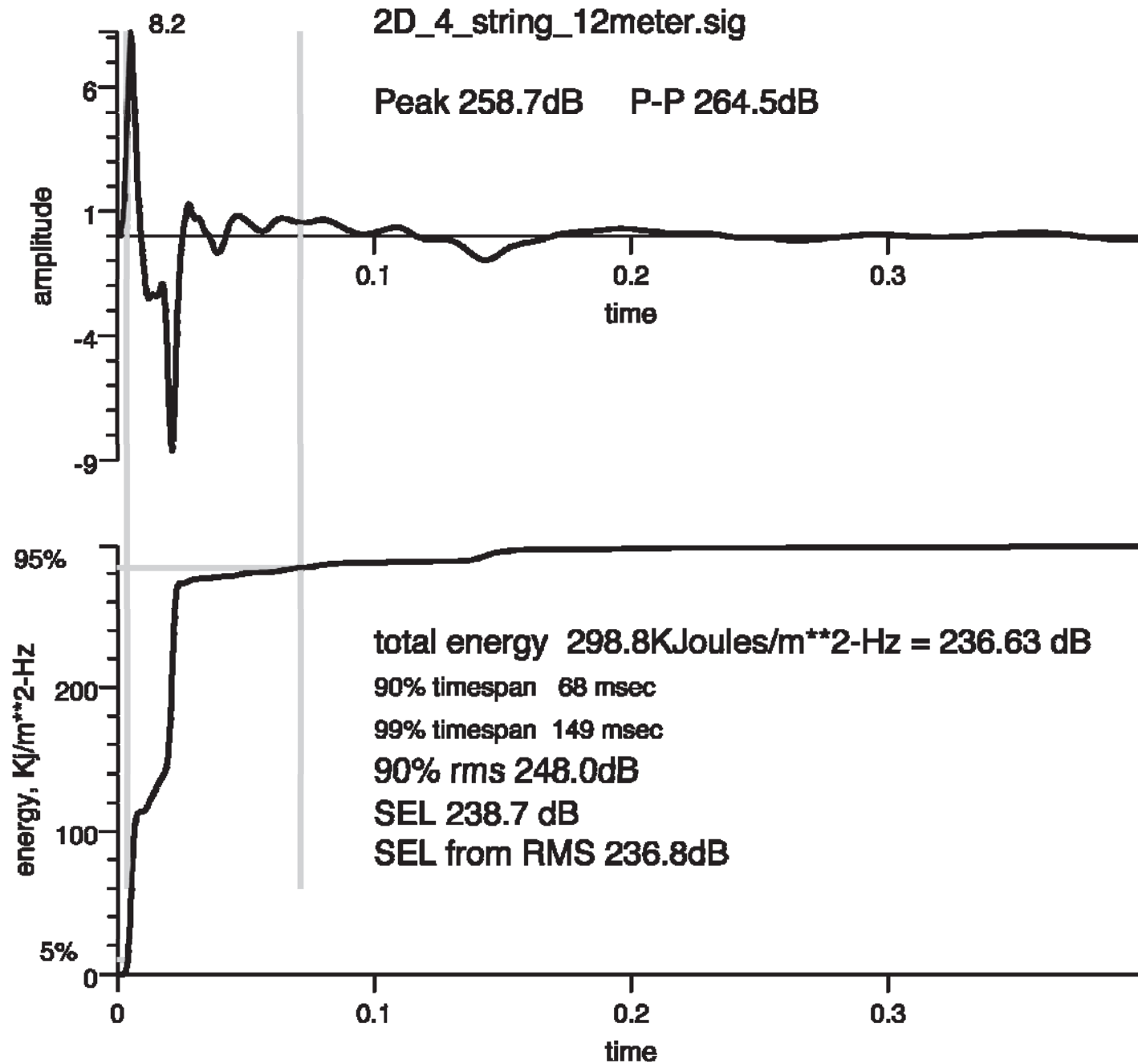

90%RMS: Other oddities

2 x 250 G gun Cluster directivity

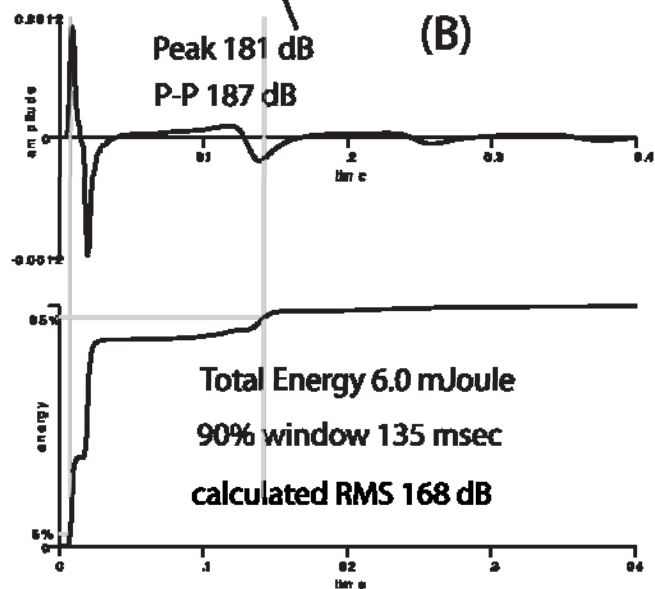
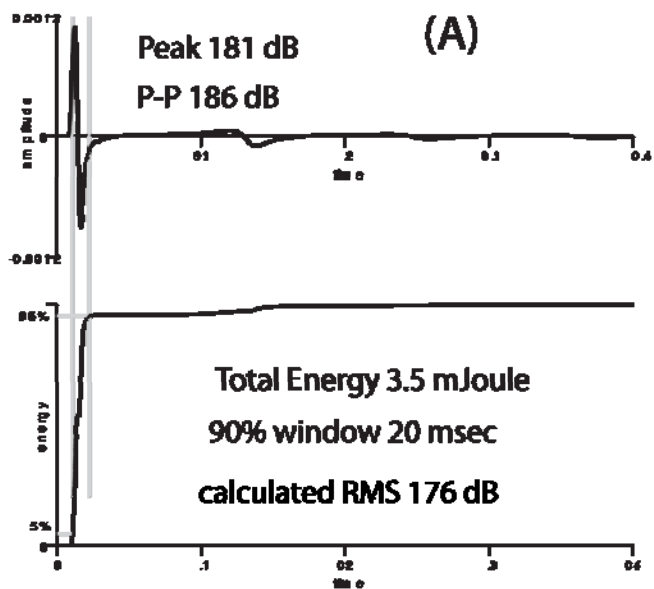
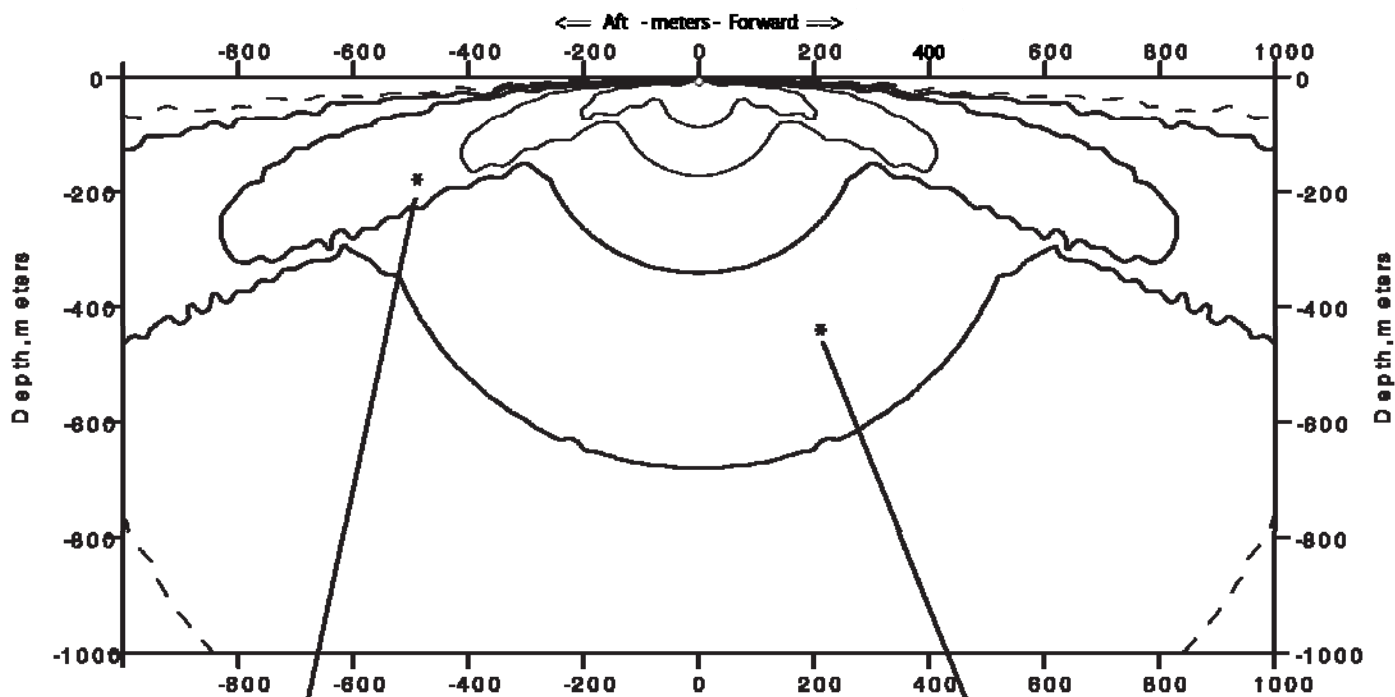

Source Models for Airgun Arrays

Wm. T. Ellison, PhD
Marine Acoustics, Inc.
890 Aquidneck Ave,
Middletown, RI 02842

Presentation at the ESRF Workshop
“Sound Measurement in the Beaufort Sea”
14-15 July 2009
Calgary, Canada’

MAI-INC

**Fig 1. CASS/GRAB Source 3D Source Directivity vs. Frequency
Comparison to Gundalf**

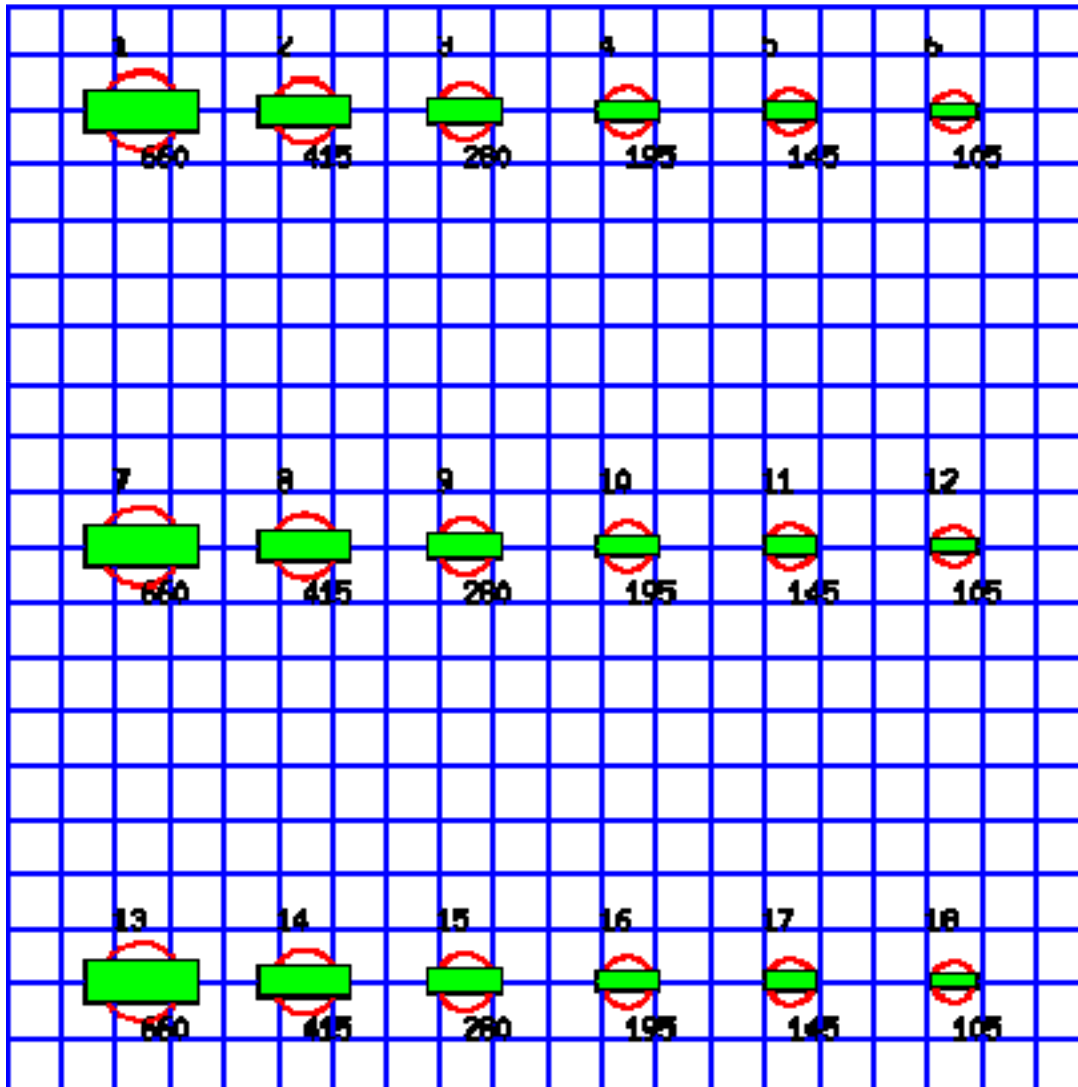

Array configuration used:
Values listed are airgun number (above) and volume in cubic inches (below).
Squares are 1m x 1m

MAI-INC

Fig 2. CASS/GRAB Source 3D Source Directivity vs. Frequency Comparison to Gundalf

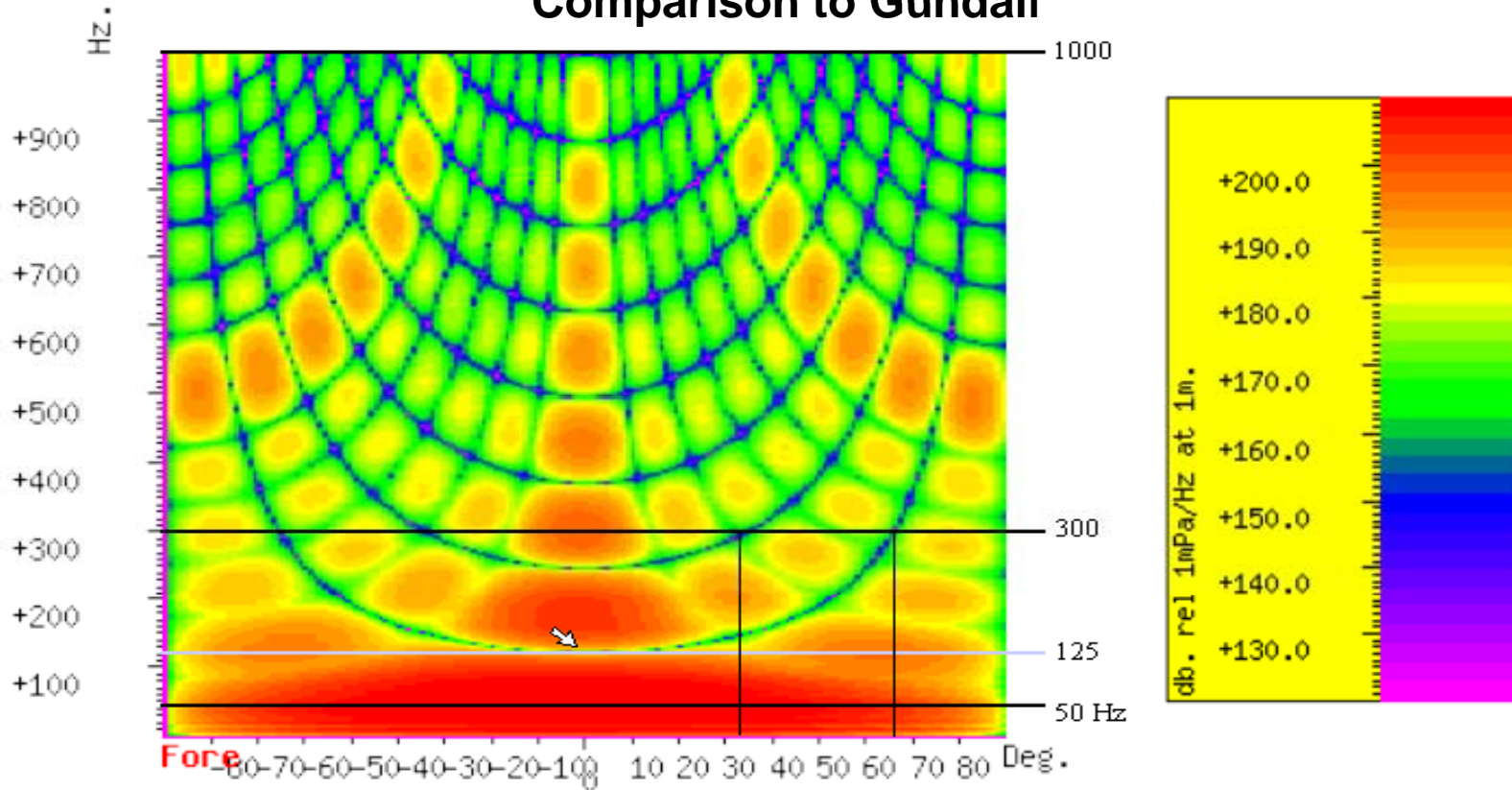

GUNDALF Pattern The vertical black lines indicate destructive interference nulls. A horizontal gray line is drawn at 125 Hz with the arrowhead pointing out that destructive interference essentially eliminates the downward beam at this frequency. The angles at which destructive interference (ghosting) occurs is used for further comparison of Gundalf and CASS/GRAB (see text).

**Fig. 3 CASS/GRAB Source 3D Source Directivity vs. Frequency
Comparison to Gundalf**

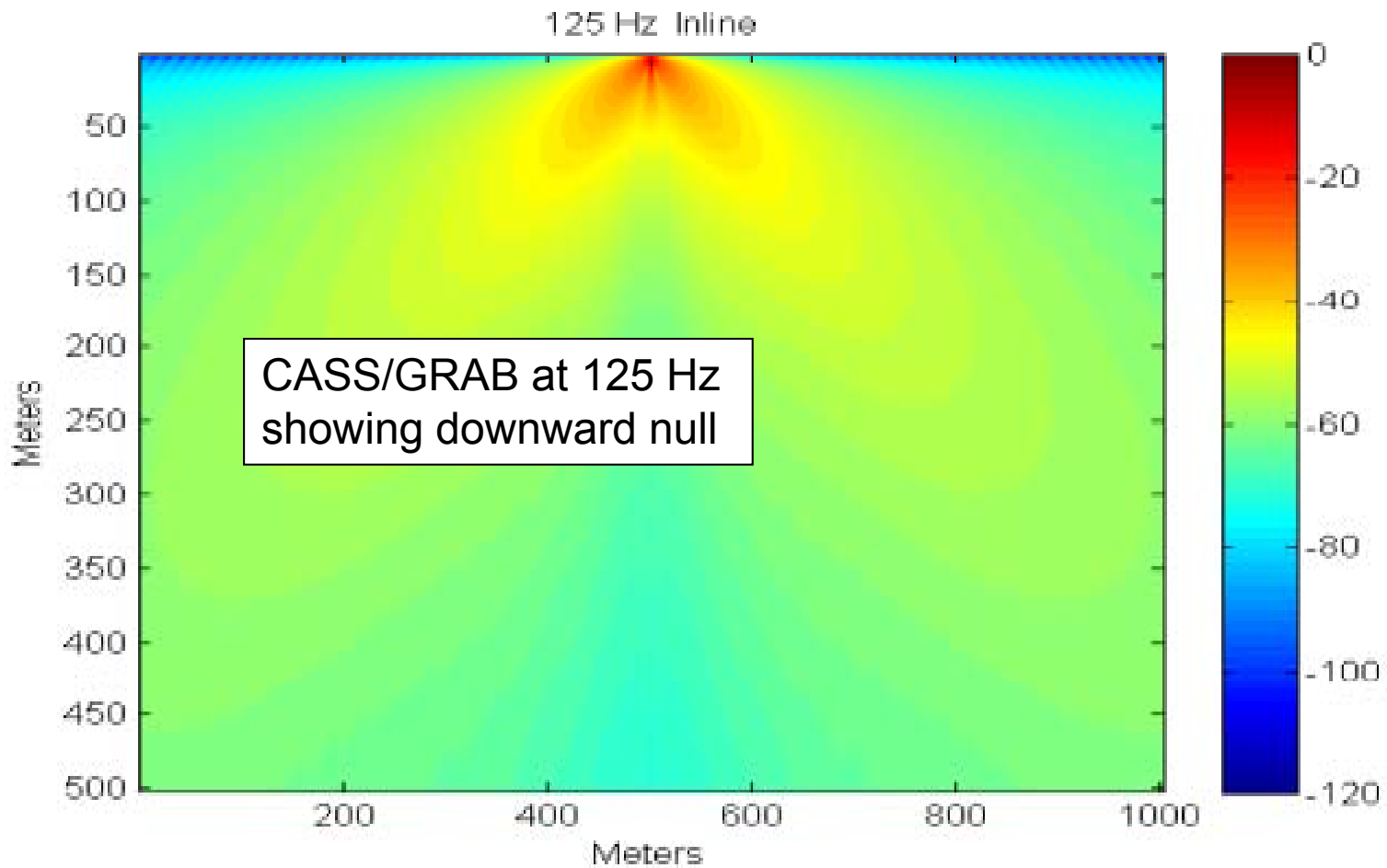

MAI-INC

**Fig. 4 CASS/GRAB Source 3D Source Directivity vs. Frequency
Comparison to Gundalf**

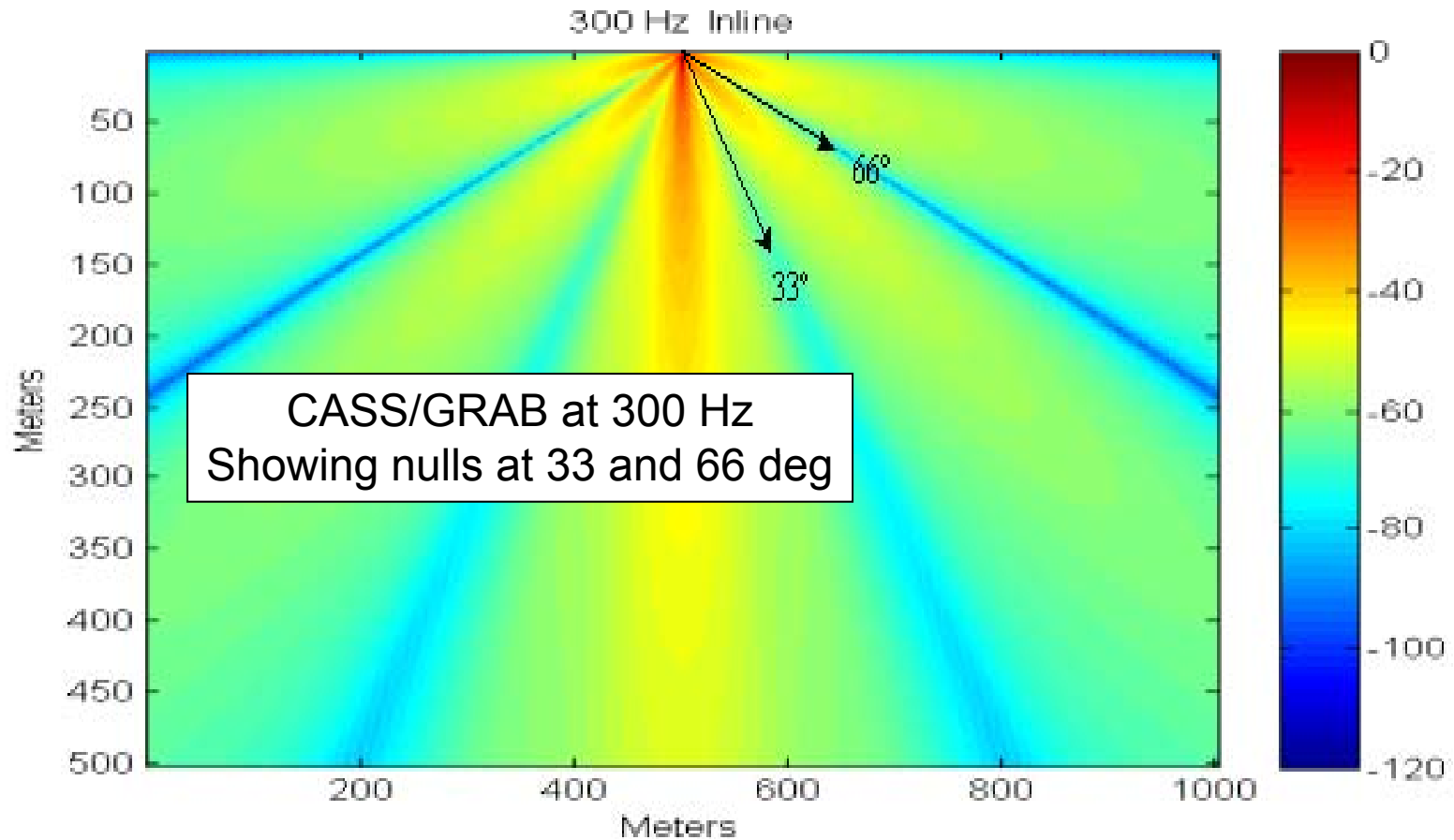

MAI-INC

Fig. 5 Modeled Beam Patterns for a Simple 7 Element Array (50, 300 and 1000Hz)

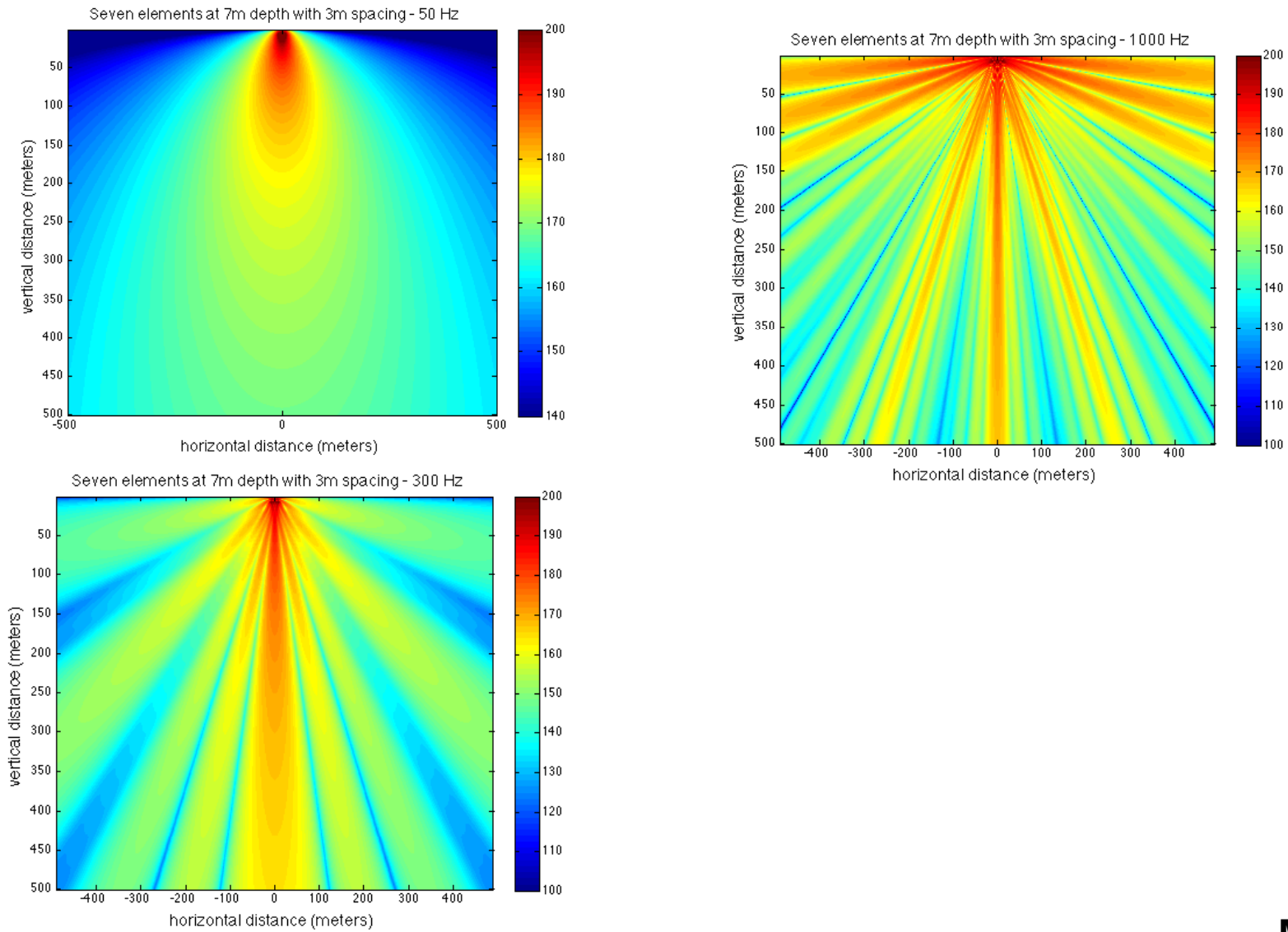

MAI-INC

Fig. 6 Particle Velocity Single Element at 50Hz

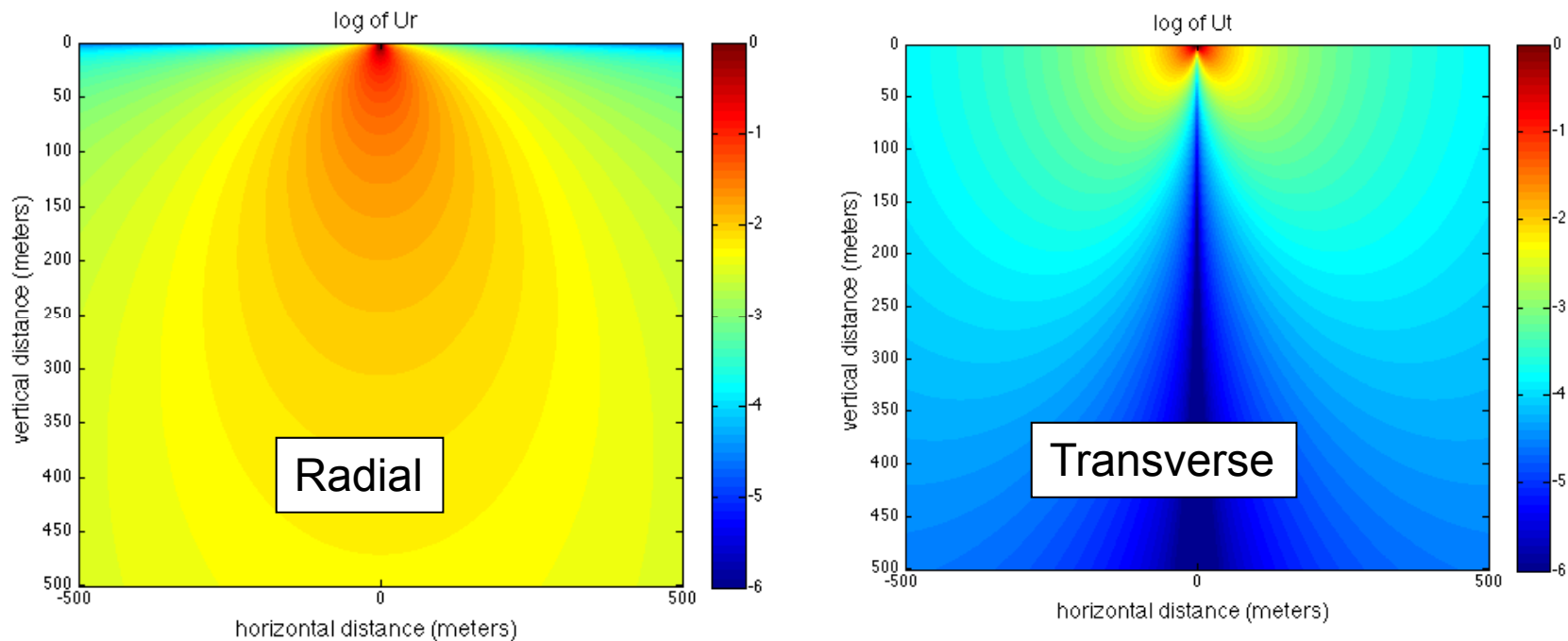

At low frequencies, the particle velocity field $[u_R \mathbf{i}_R + u_T \mathbf{i}_T]$ of a dipole is given by Junger and Feit (1972, Eq. 3.10 et. seq.), where \mathbf{i}_R and \mathbf{i}_T represent the unit vectors in the radial and tangential directions respectively:

$$|u_R| = (2P_0/rc)(R_0/R)(1/kR)(1+(kR)^2)^{1/2} \sin(kr \cos(Q))$$

$$|u_T| = (2P_0/rc)(R_0/R)(1/kR)(kr \sin(Q) \cos(kr \cos(Q)))$$

MAI-INC

Fig. 7
Modeling a
Simple Line
Array

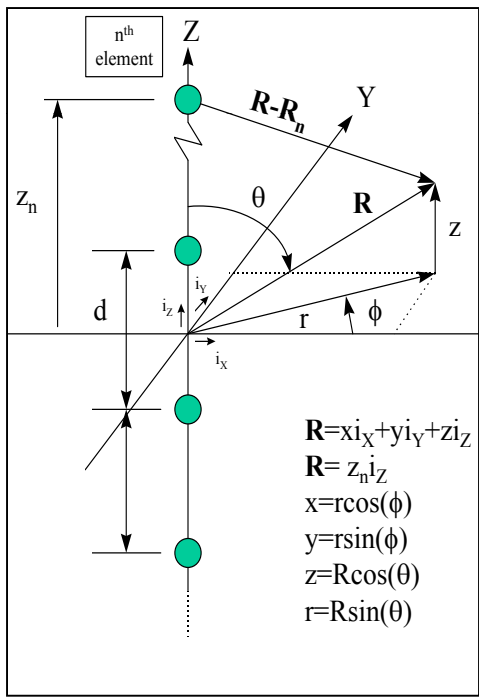

$$P_n[\mathbf{R}] = \{PE/|\mathbf{R}-\mathbf{R}_n|\}\{\cos(k|\mathbf{R}-\mathbf{R}_n|) + i \sin(k|\mathbf{R}-\mathbf{R}_n|)\}$$

$$P[\mathbf{R}] = \sum P_n[\mathbf{R}], n=1,N$$

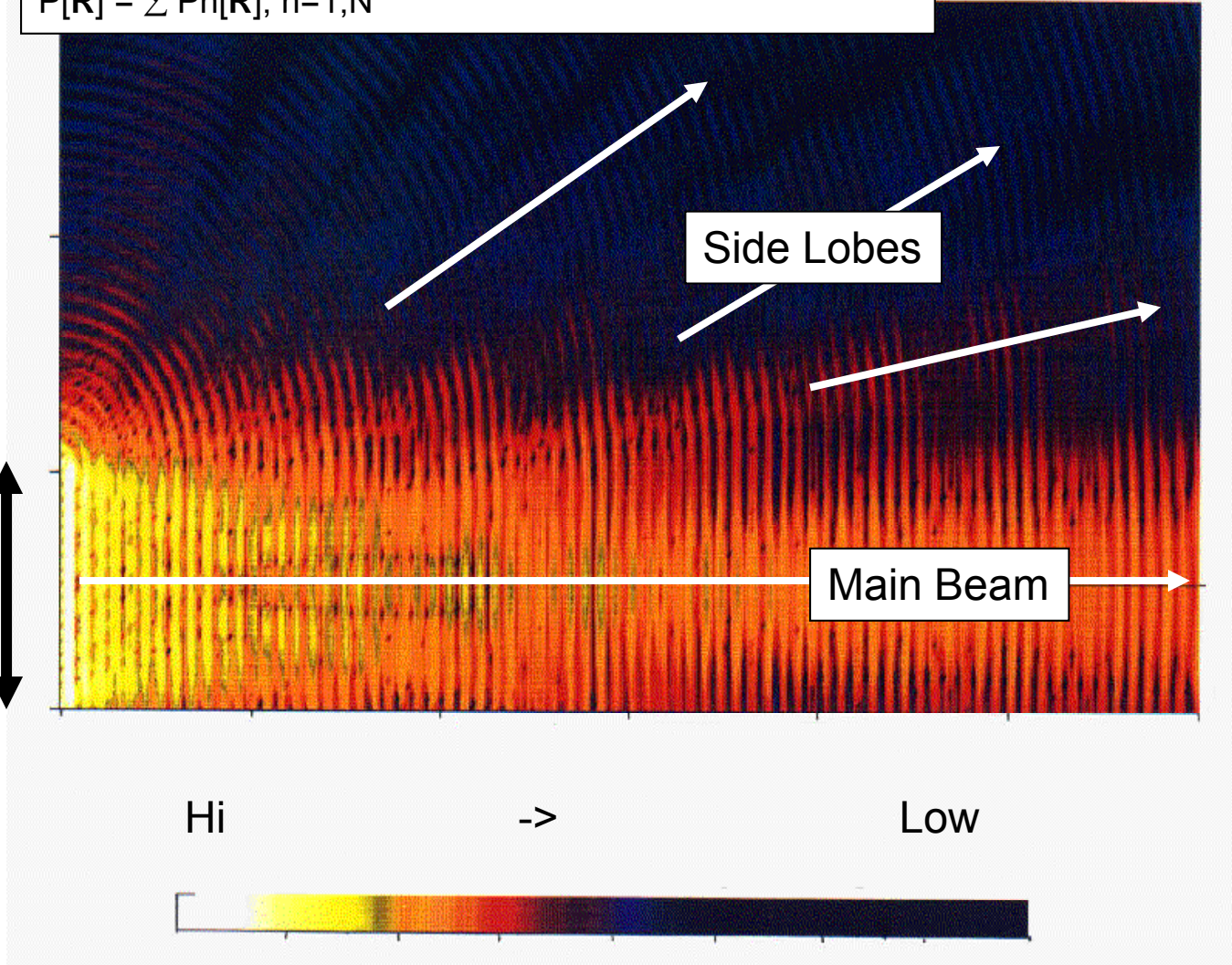

MAI-INC



Propagation Modelling (Beaufort Sea Conditions)

Roberto Racca

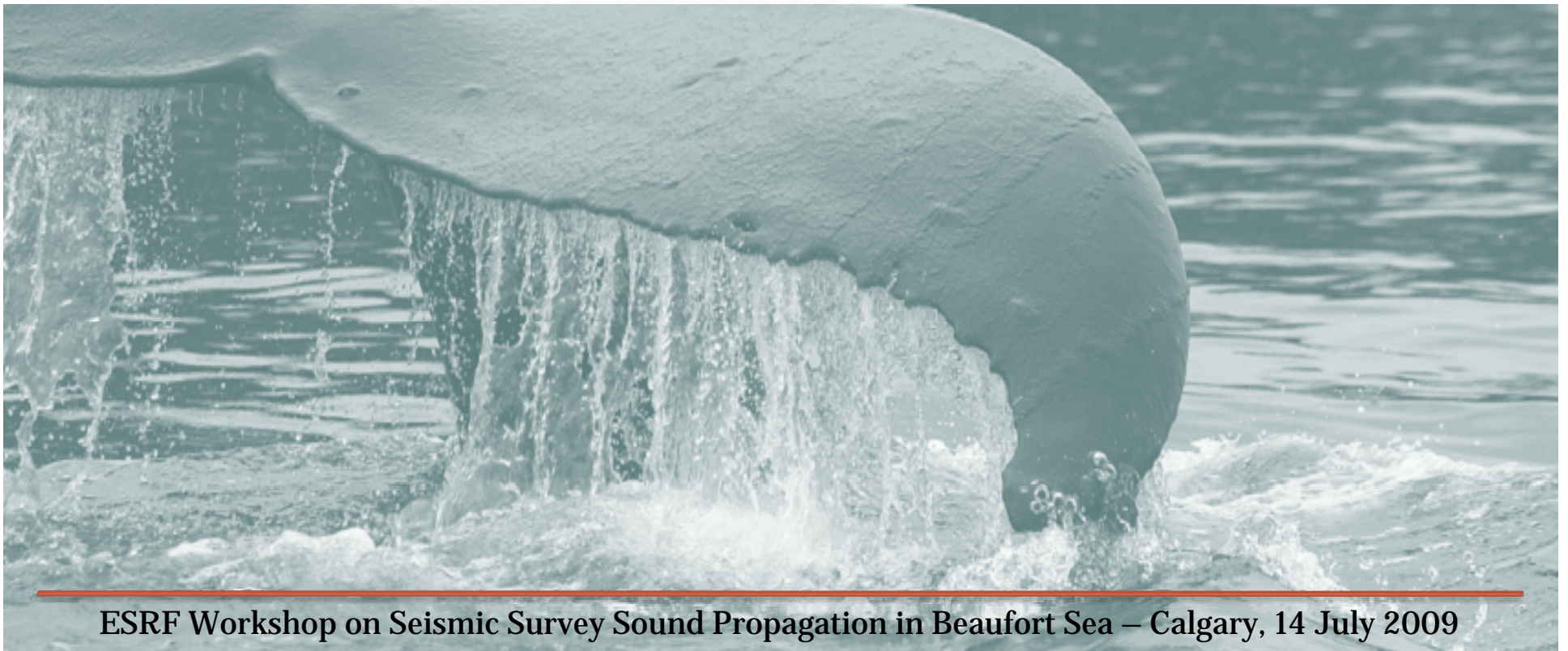

ESRF Workshop on Seismic Survey Sound Propagation in Beaufort Sea – Calgary, 14 July 2009

Points that we shall cover

- Basics of sound propagation modelling
- How acoustic models are used for assessment of potential impact on marine mammals and for mitigation planning
- Modelling of seismic survey footprints
- Important characteristics of Beaufort Sea environments that affect sound propagation



What is propagation modelling?

- Refers to the use of computer models to predict how sounds are attenuated as they propagate in the ocean

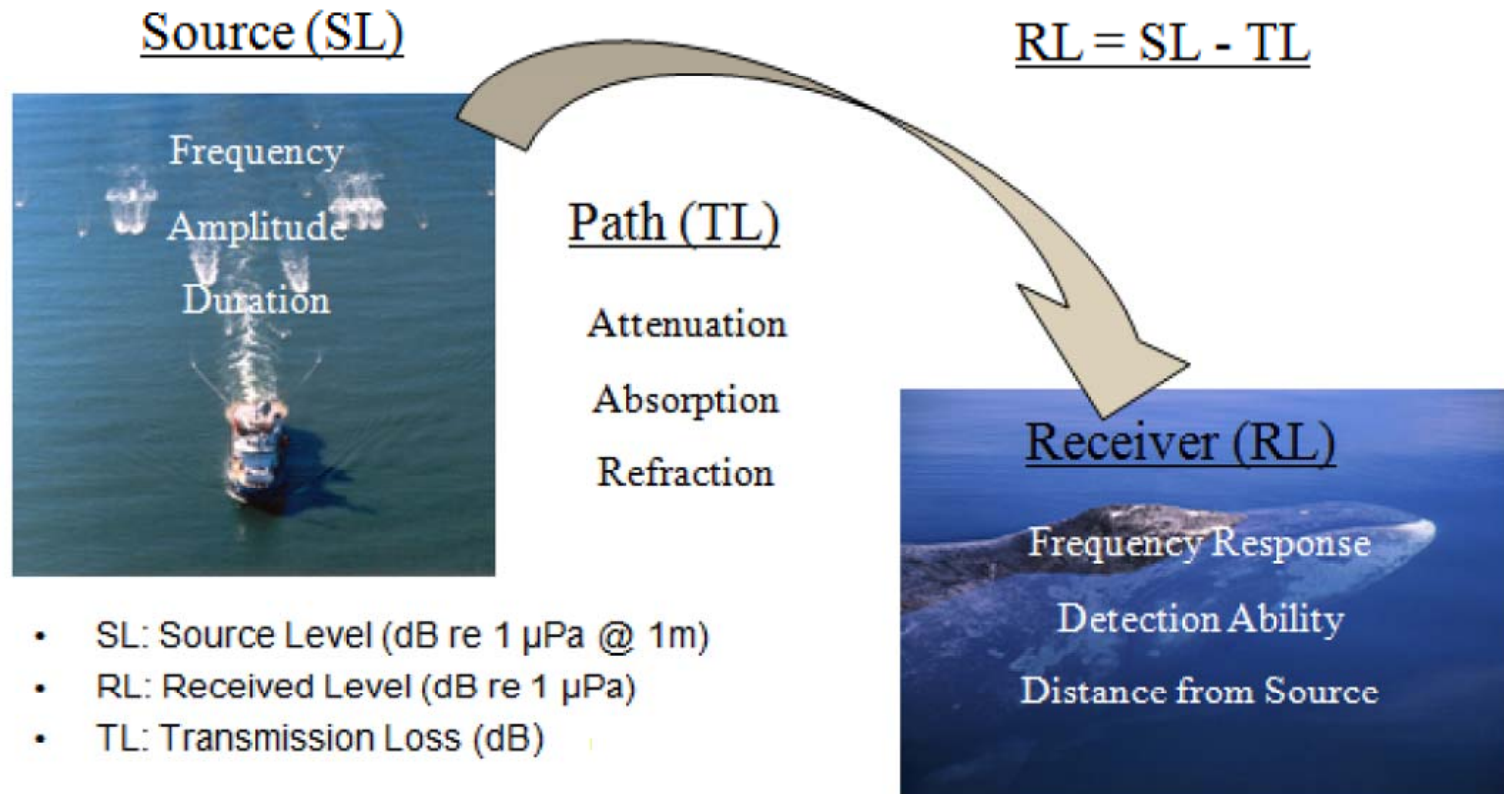

How do acoustic models work?

- All start with source pressure levels (SL)
- Model can be as simple as a basic equation, e.g. the spherical spreading loss: $RL = SL - 20 \log(\text{distance})$
- Advanced models solve complex equations defining how pressure waves at different frequencies interact with the physical environment (surface, water, bottom)

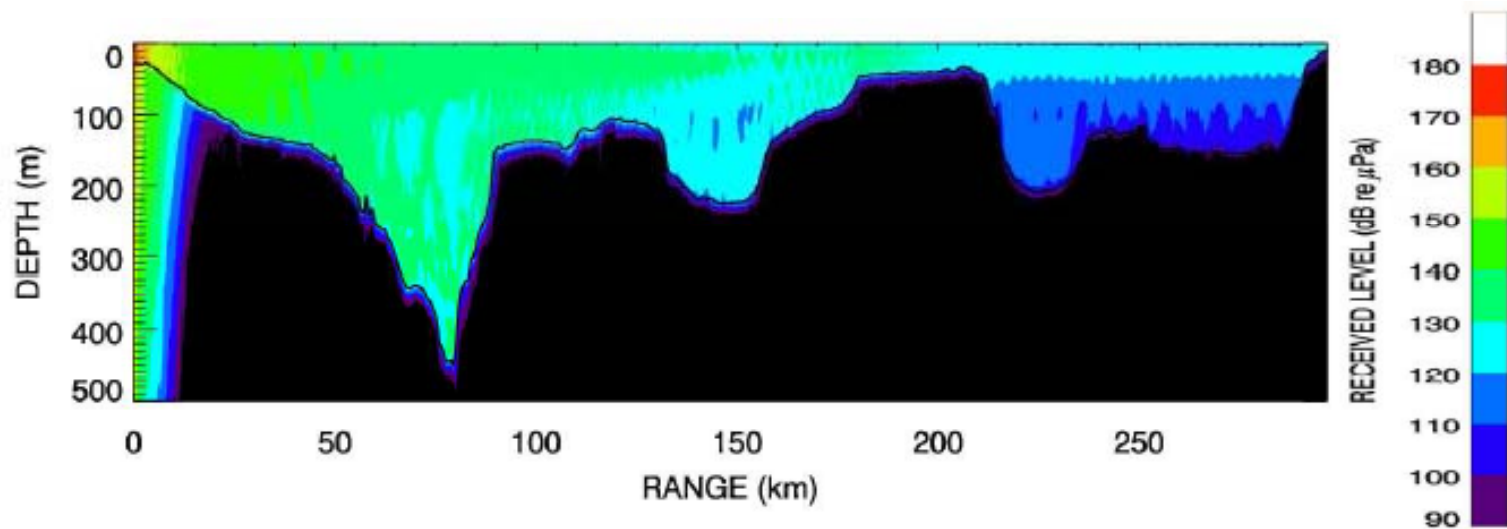

How are models used to mitigate impacts on marine mammals?

- **Models can predict the size of the zones over which sound levels exceed marine mammal impact thresholds, and for sub-injury (behaviour response) thresholds can provide estimates of number of individuals potentially affected**
- **Models can be used to assess the effectiveness of certain mitigation measures, such as:**
 - Changing the orientation of the seismic lines
 - Using a different airgun configuration
 - Adjusting airgun timing within the array

An example of “what if” analysis

- Goal: minimize seismic noise levels in proximity of coastline
- Effects of tow depth of array (here shown for 4, 5 and 6m) and orientation of survey lines can be assessed through runs of model
- Array design changes can likewise be vetted in terms of effect on propagation footprint

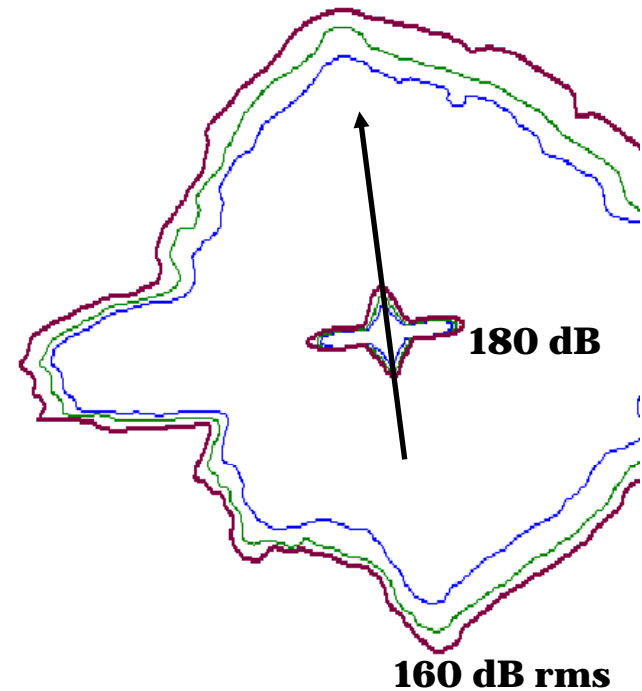

From pulses to footprints (how the sound truly radiates)



Estimation of exclusion radius for irregularly shaped footprints

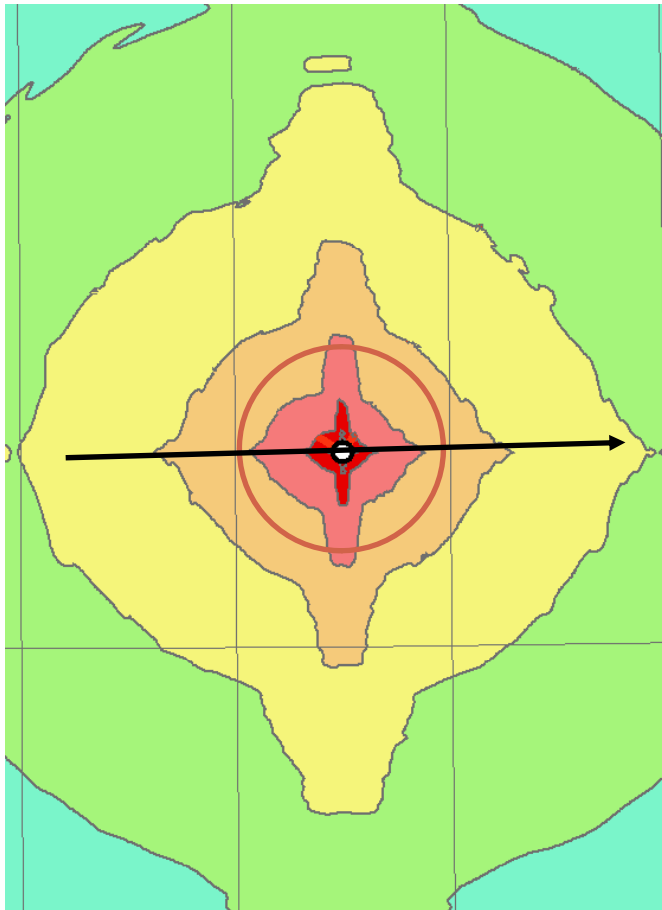

- Currently based on extent of sound level contour to 180 dB re μPa *rms* threshold
- Stability of estimate improved by choosing the radius of the circle that encompasses 95% of the area ensonified above 180 dB re μPa *rms*
- Still precautionary, as the 95% circle is mostly well beyond the 180 dB contour

Summer sound speed profiles for the Canadian Beaufort

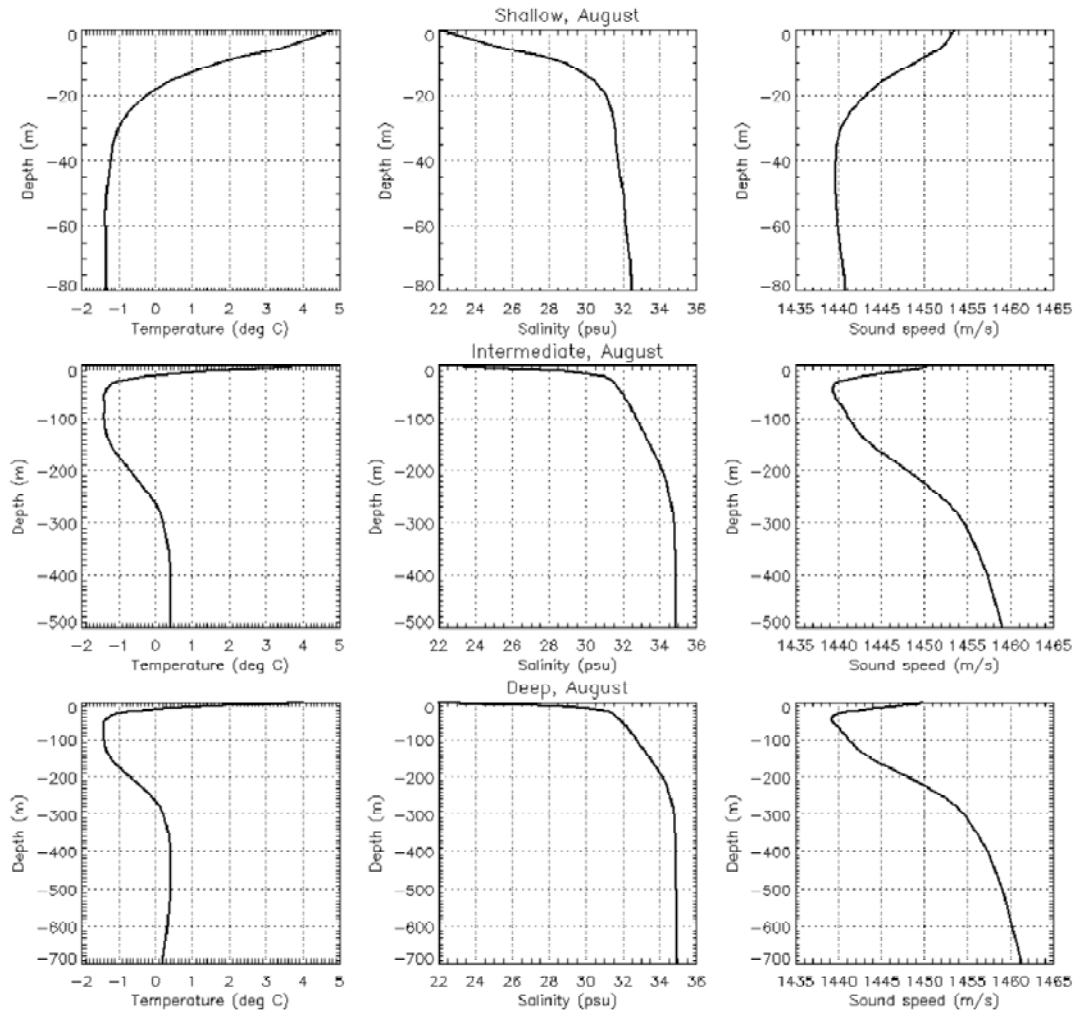

Sea bottom properties for the Canadian Beaufort

- Large changes in bathymetry due to shelf drop-off
- Variability in geoacoustics due to lithologic zonation and localized regions of permafrost

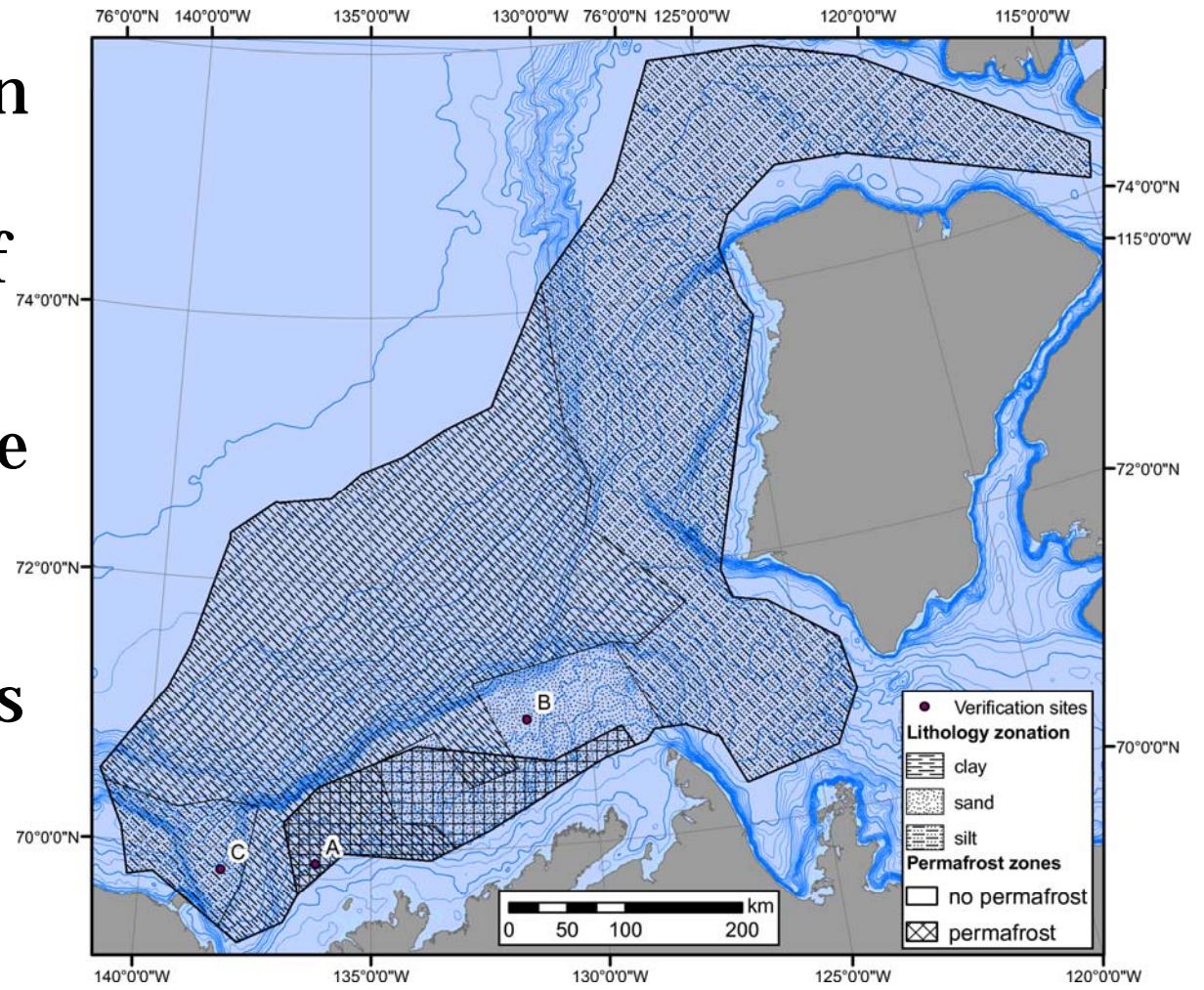

Unique challenges in propagation modelling for the Beaufort area

- There is strong geographic variability in the sound propagation environment due to bathymetry changes, water sound speed profile differences in various depth regions, and marked geoacoustic zonation
- As a result, estimated sound propagation footprints to given threshold levels can be very different depending on the areas where surveys are to be conducted
- A single survey line may span regions having widely different propagation properties, requiring adaptive adjustment of safety radii based on pre-computed estimates from modelling



Impact Radii and CSEL

David Hannay, JASCO

**ESRF Workshop: Seismic Survey Sound
Propagation in the Beaufort Sea**



Overview

- **Review of Cumulative SEL metric and M-Weighting.**
- **Southall et al Criteria for Permanent Hearing Threshold Shift (PTS)**
- **Measurements of M-Weighted CSEL for a 3-D survey in 40 m water depth.**
- **Summary of approximate PTS distance ranges for pinnipeds and cetaceans from a 3-D survey.**

M-Weighting

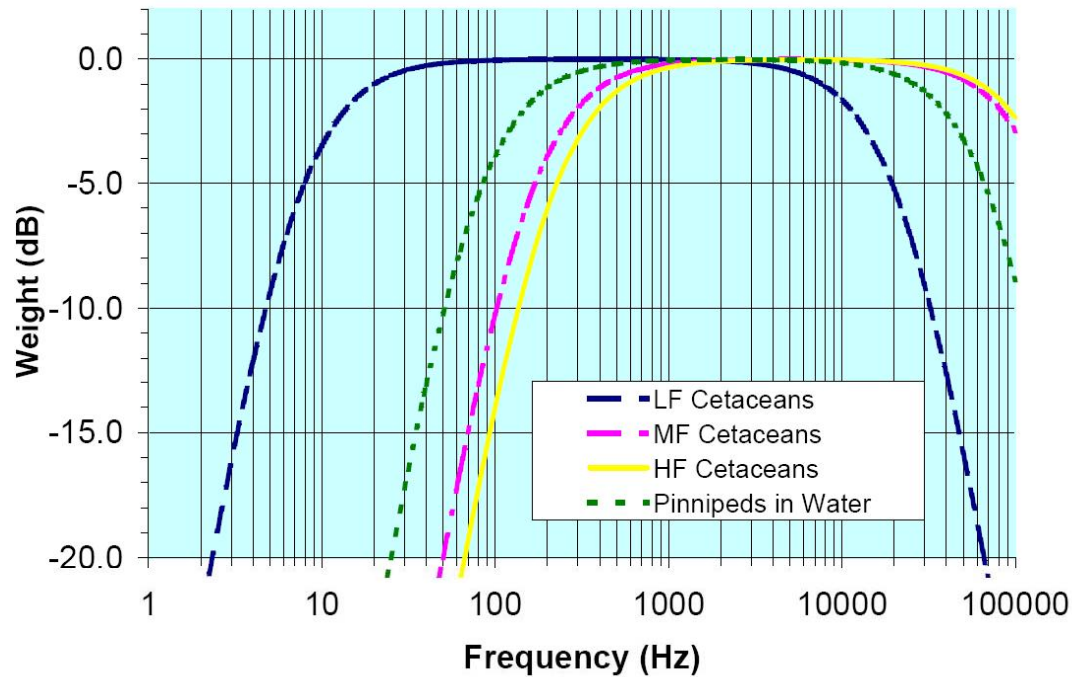

$$G(f) = -20 \log_{10} \left[\left(1 + \frac{f_{lo}^2}{f^2} \right) \left(1 + \frac{f^2}{f_{hi}^2} \right) \right]$$

<i>M-weighting filter</i>	f_{lo} (Hz)	f_{hi} (Hz)
<i>Low frequency cetaceans (LFC)</i>	7	22000
<i>Mid-frequency cetaceans (MFC)</i>	150	160000
<i>High-frequency cetaceans (HFC)</i>	200	180000
<i>Pinnipeds underwater (PINN)</i>	75	75000

Measured M-Weighted Cumulative SEL

- Per-shot SEL and M-weighted cumulative SEL at 500 m off a 3-D seismic line, 40 m depth.

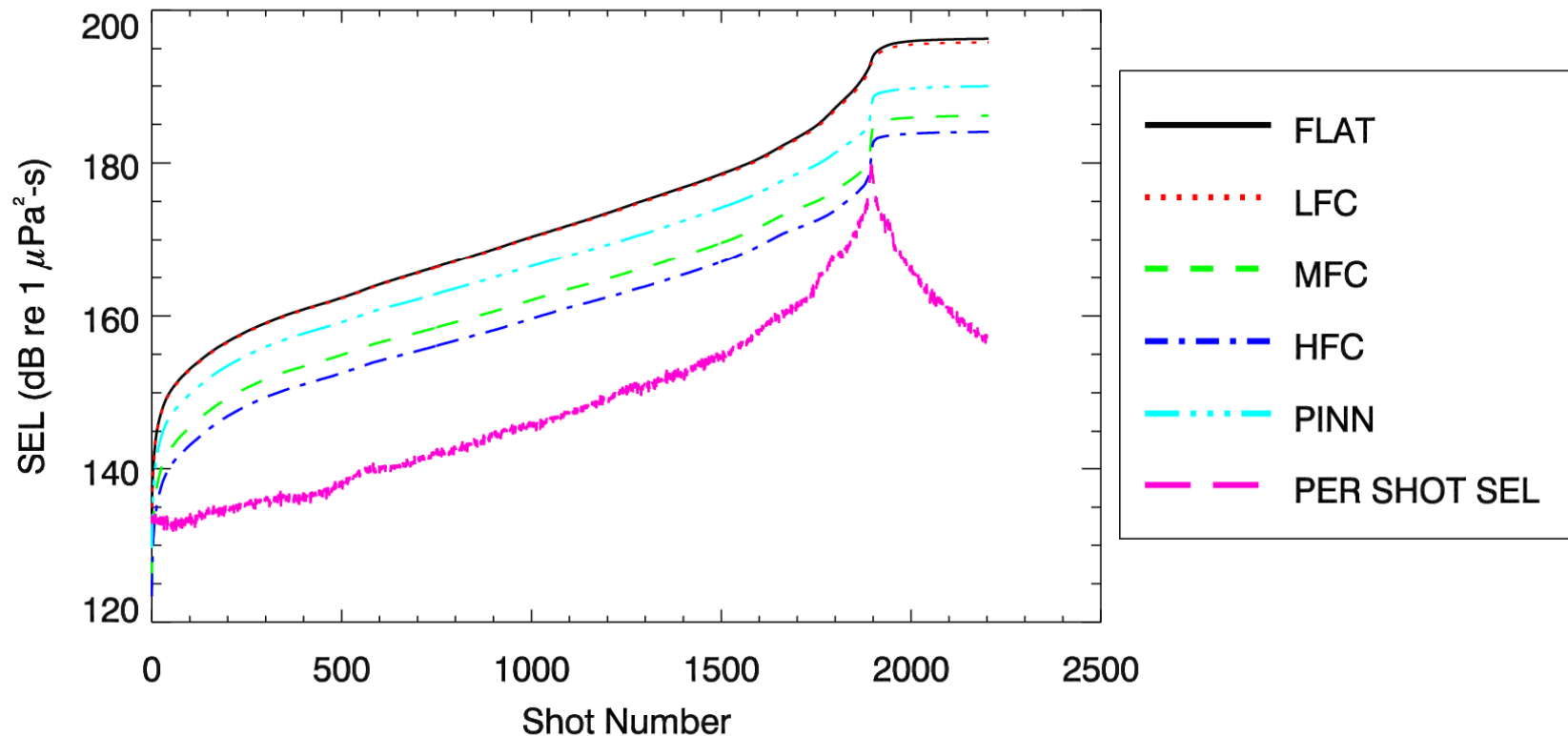

M-Weighted Cumulative SEL versus distance offline

- Regression fits to M-weighted cumulative SEL versus distance off a seismic line for a 3-D program in 40 m water depth.

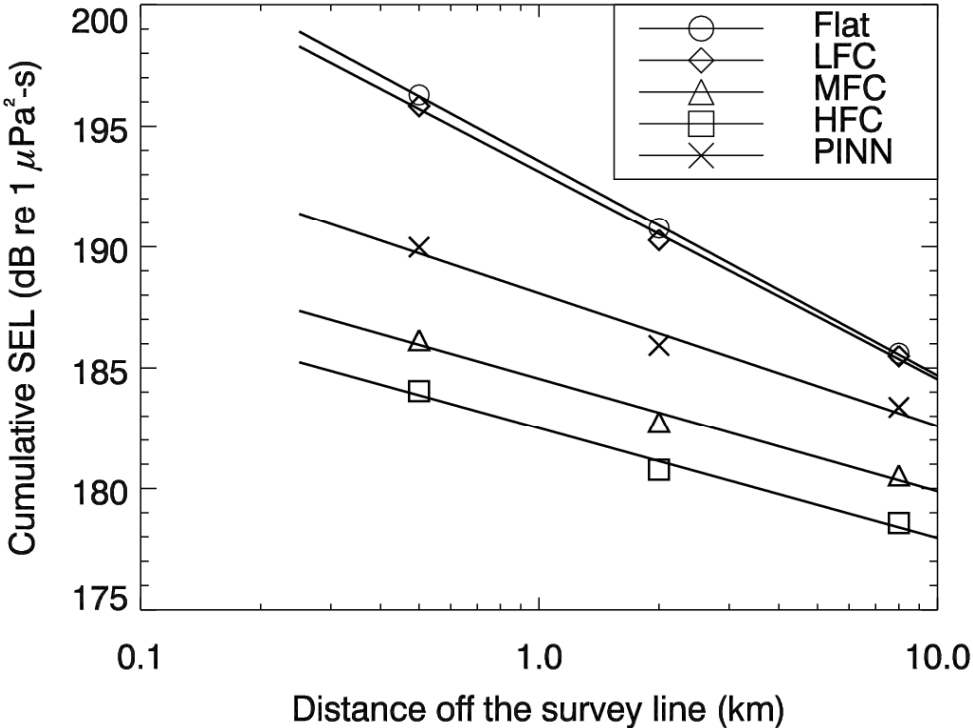

Summary of Southall et al Criteria

- TTS onset in Cetaceans is 183 dB SEL re 1 μ Pa (M-weighted), or 230 dB re 1 μ Pa peak (flat weighted).
- TTS onset in Pinnipeds is 171 dB SEL re 1 μ Pa (M-weighted), or 218 dB re 1 μ Pa peak (flat weighted).
- PTS onset in Cetaceans is 198 dB re 1 μ Pa SEL (M-weighted), or 230 dB re 1 μ Pa peak (flat weighted).
- PTS onset in Pinnipeds is 186 dB re 1 μ Pa SEL (M-weighted), or 218 dB re 1 μ Pa peak (flat weighted).

Summary

- Peak pressure criteria for PTS are encountered only very near airgun arrays.
- M-Weighted SEL criteria for PTS in cetaceans could be encountered to a few hundred meters off-line
- M-Weighted SEL criteria for PTS in pinnipeds could be encountered to a few kilometers off-line.
- Specific distances for measurement example in 40 m water depth were 270 m for LF cetaceans and 2400 m for pinnipeds.

Calculating CSEL: A Virtual Example using AIM

Wm. T. Ellison, PhD
Marine Acoustics, Inc.
890 Aquidneck Ave,
Middletown, RI 02842

Presentation at the ESRF Workshop
“Sound Measurement in the Beaufort Sea”
14-15 July 2009
Calgary, Canada

The Key Elements of the Problem

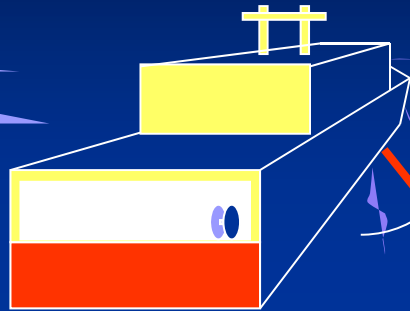

Step#1-Site-specific Operational Scenario

- SL (freq, Tp, PI)
- 'A' (lat/lon/depth, time)

Step#3-Acoustic Transmission Loss ,TL (f,t) A to B

Step#4- Determine individual Whale

$RL(f,t) = SL - TL$

'Dosimeter'

Step#2-Seasonal Distribution & Diving Behavior

- By individuals (n) in each species (S)
- 'B' (S, n, lat/lon/depth, time)



MAI-INC

Basic Concept of AIM: Block Diagram of Components & Data Flow

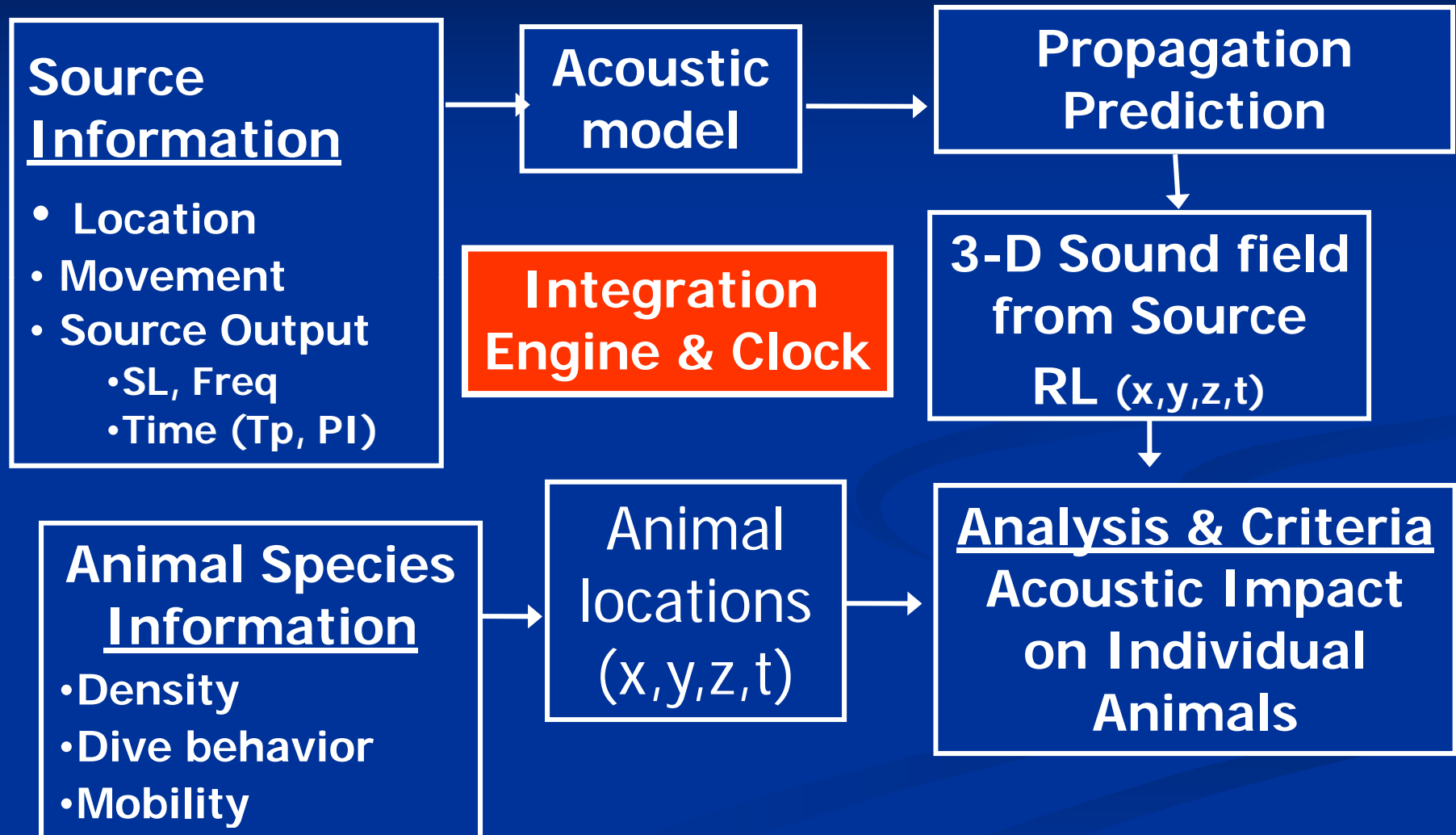

Fig. 3
Model Output
and Interpretation

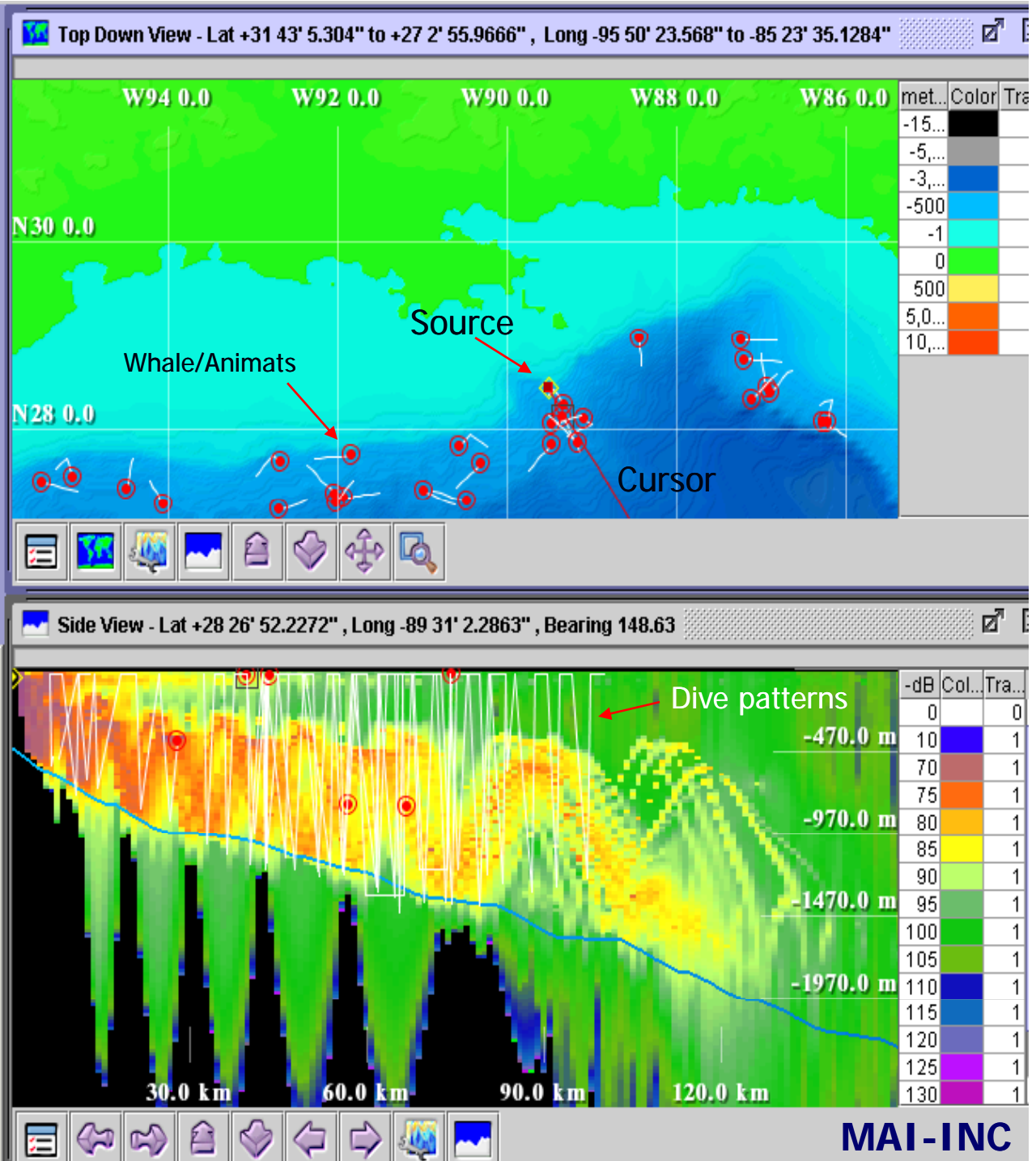
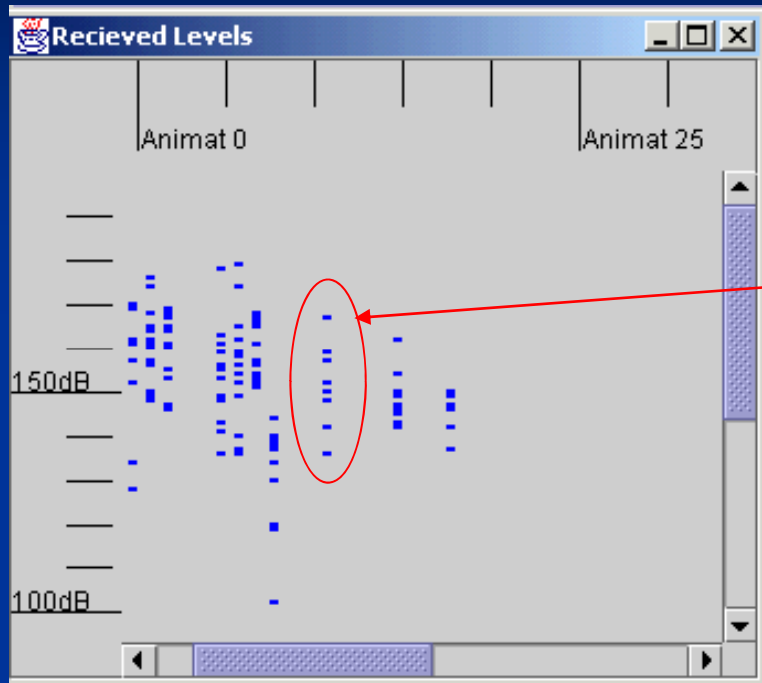

Fig. 4 - Determining C-SEL



Example: For each whale the SEL values for each exposure are summed to determine the CSEL:

{168, 160, 157, 151, 150, 149, 141, 135}

SEL	p ²
168	6.30957E+16
160	1E+16
157	5.01187E+15
151	1.25893E+15
150	1E+15
149	7.94328E+14
141	1.25893E+14
135	3.16228E+13
sum=	8.13184E+16
C-SEL	169

Note that this simplified example assumes:

1. constant sound duration for each individual exposure.
2. Individual exposures are of the same time duration

Comment: If each of the exposures actually represented 20 pulses (about 3 minutes for seismic) then the SEL would grow by $10\log(20)$ or about 13 dB with a C-SEL of 182dB.

MAI-INC



Empirical Measurements,
Canadian Beaufort.

David Hannay, JASCO

**ESRF Workshop: Seismic Survey Sound
Propagation in the Beaufort Sea**



Overview

- **Summary of Measurement Programs performed by JASCO since 2001**
- **Measurement Approaches**
- **Results**

- **10 m water depth**

Level / Aspect	Range for RMS	Range for Peak
190 dB Range (Fore/Aft)	186 m	602 m
190 dB Range (Broadside)	280 m	790 m
180 dB Range (Fore/Aft)	587 m	1978 m
180 dB Range (Broadside)	861 m	2260 m
160 dB Range (Fore/Aft)	4110 m	9620 m
160 dB Range (Broadside)	5330 m	11200 m

- **16 m water depth**

Level / Aspect	Range for RMS	Range for Peak
190 dB Range (Fore/Aft)	146 m	512 m
190 dB Range (Broadside)	402 m	889 m
180 dB Range (Fore/Aft)	534 m	1840 m
180 dB Range (Broadside)	1370 m	2890 m
160 dB Range (Fore/Aft)	4600 m	10100 m
160 dB Range (Broadside)	8150 m	12600 m

- Measurements in 34-38 m depth. Buoys deployed on seabed.

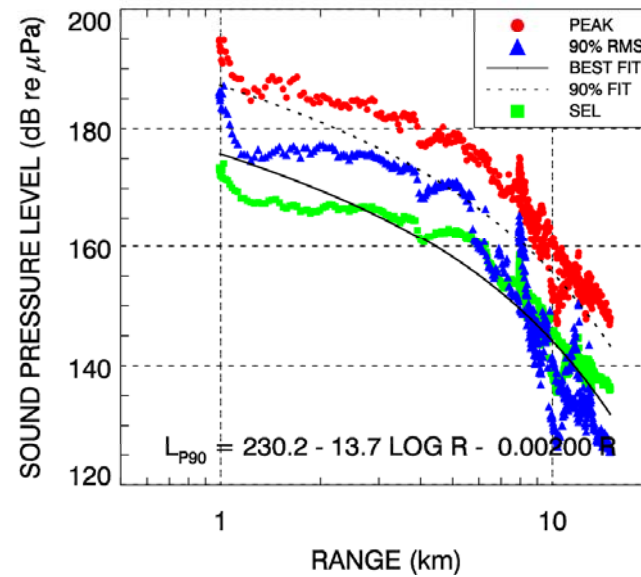
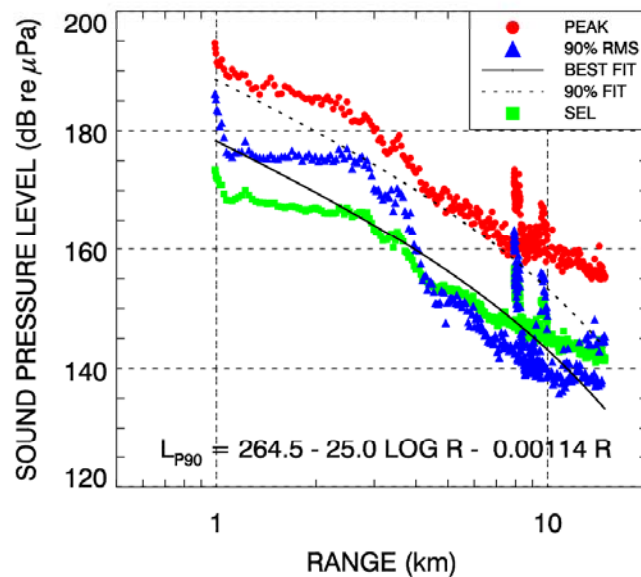

- Recorder at 160 m depth, anchored on long-line to seabed.

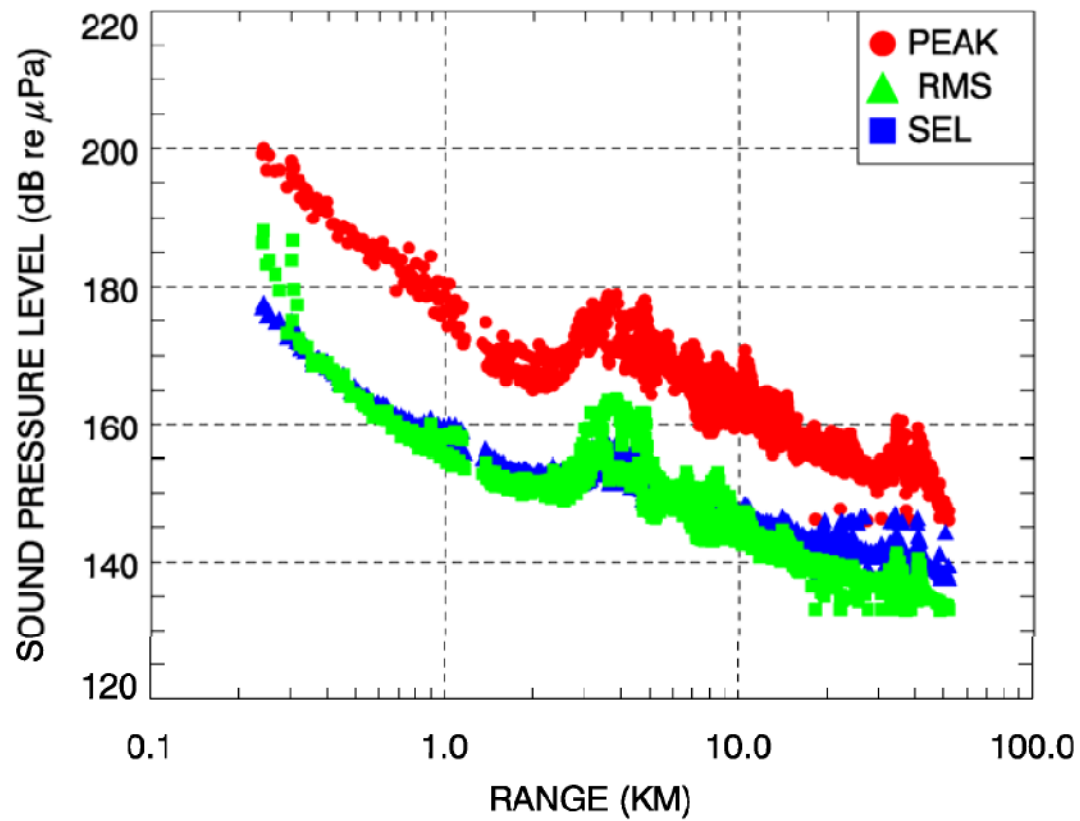

- Recorder at 160 m depth, anchored on long line to seabed (broadside).

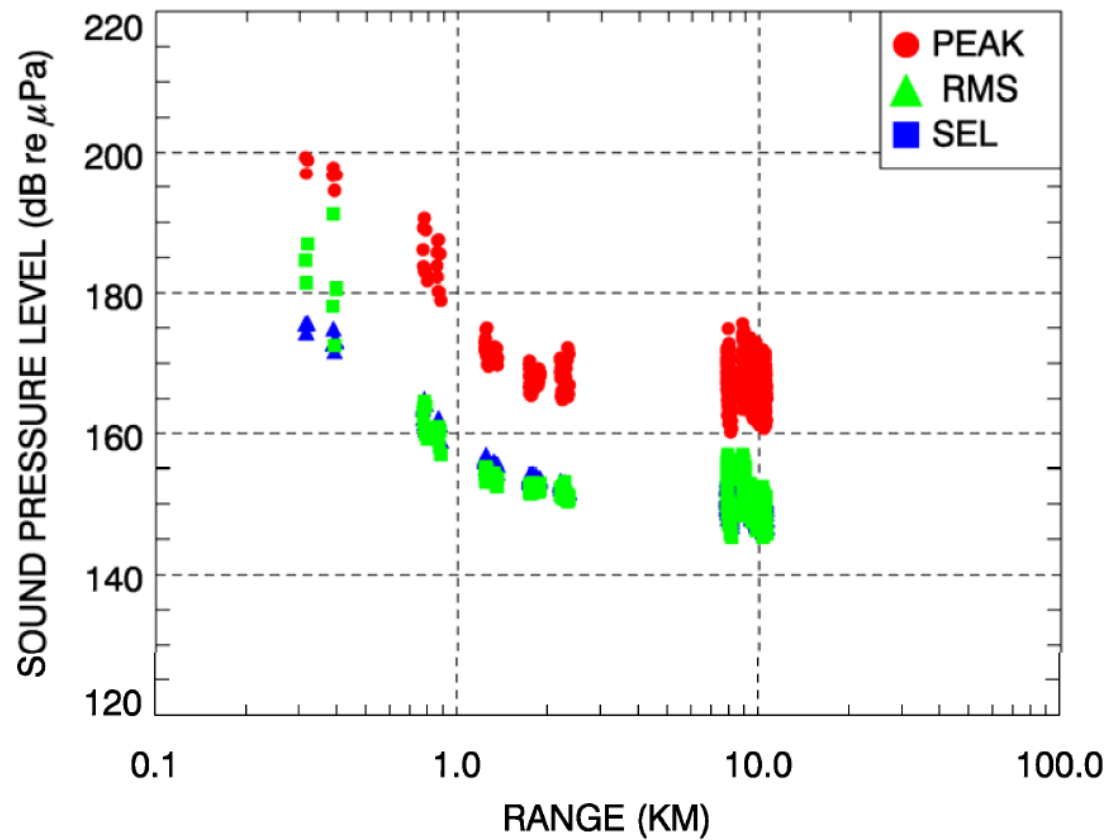

- Recorder at 160 m depth, anchored on long line to seabed (endfire).

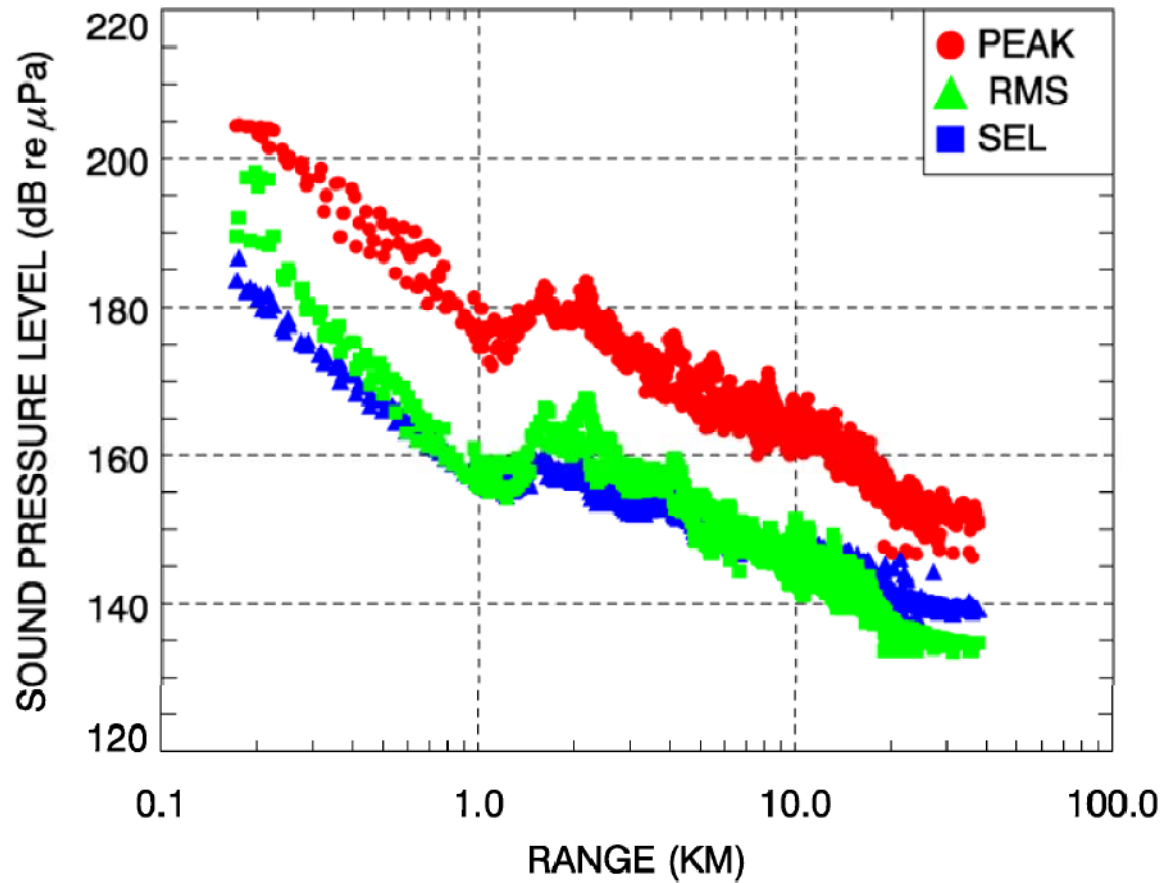

- Recorder at 160 m depth, anchored on long line to seabed (broadside).

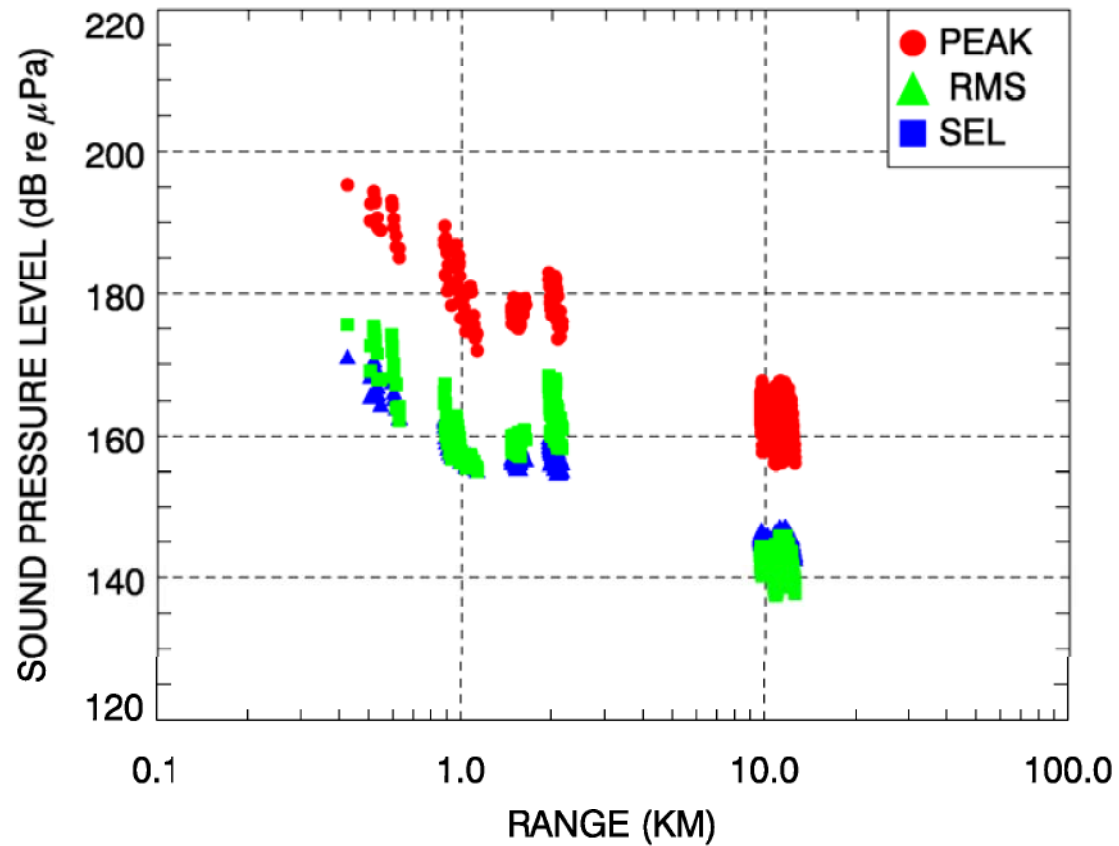

Summary

- Shallow (less than 40 m water depth) threshold distances to to 180 dB re 1 uPa are several times greater than in deeper water.
- Difficulty measuring threshold distances in deep water environments due to depth dependence. Also need to sample the rise due to return of bottom-reflected energy.
- Should integrate modeling with measurements in deep water to obtain a more complete picture.



ESRF

Variability of Seismic Sounds Recorded in the Alaskan Beaufort Sea

William C. Burgess
Greeneridge Sciences, Inc.



ARCTIC SEISMIC RESULTS FROM PAST GREENERIDGE STUDIES

ESRF

YEAR	STUDY REGION	IMPULSE SOURCE RECORDED	FOCUS ON THIS SOURCE	STUDY SPONSOR
1980–1984	Canadian Beaufort	Sleeve exploders, open-bottom gas guns; after 1982, airguns	Incidental	BLM/MMS
1983	Alaskan Beaufort	Airguns	Systematic	MMS
1985–1986	Alaskan Beaufort	Airguns	Incidental	Shell & Unocal
1996–1997	Alaskan Beaufort	Airguns	Systematic	BP
1998–1999	Alaskan Beaufort	Airguns	Systematic	Western Geo.
2000	Alaskan Beaufort	Airgun, bubbler, chirp sonar	Systematic	Western Geo.
2006	Alaskan Beaufort	Airguns, bubbler, chirp sonar	Systematic	Shell
2006	Chukchi	Airguns	Systematic	Shell
2008	Alaskan Beaufort	Airguns	Incidental	BP & Shell



TYPICAL SEISMIC SHOWING SUB-BOTTOM WAVES & WAVEGUIDE CUTOFF

ESRF

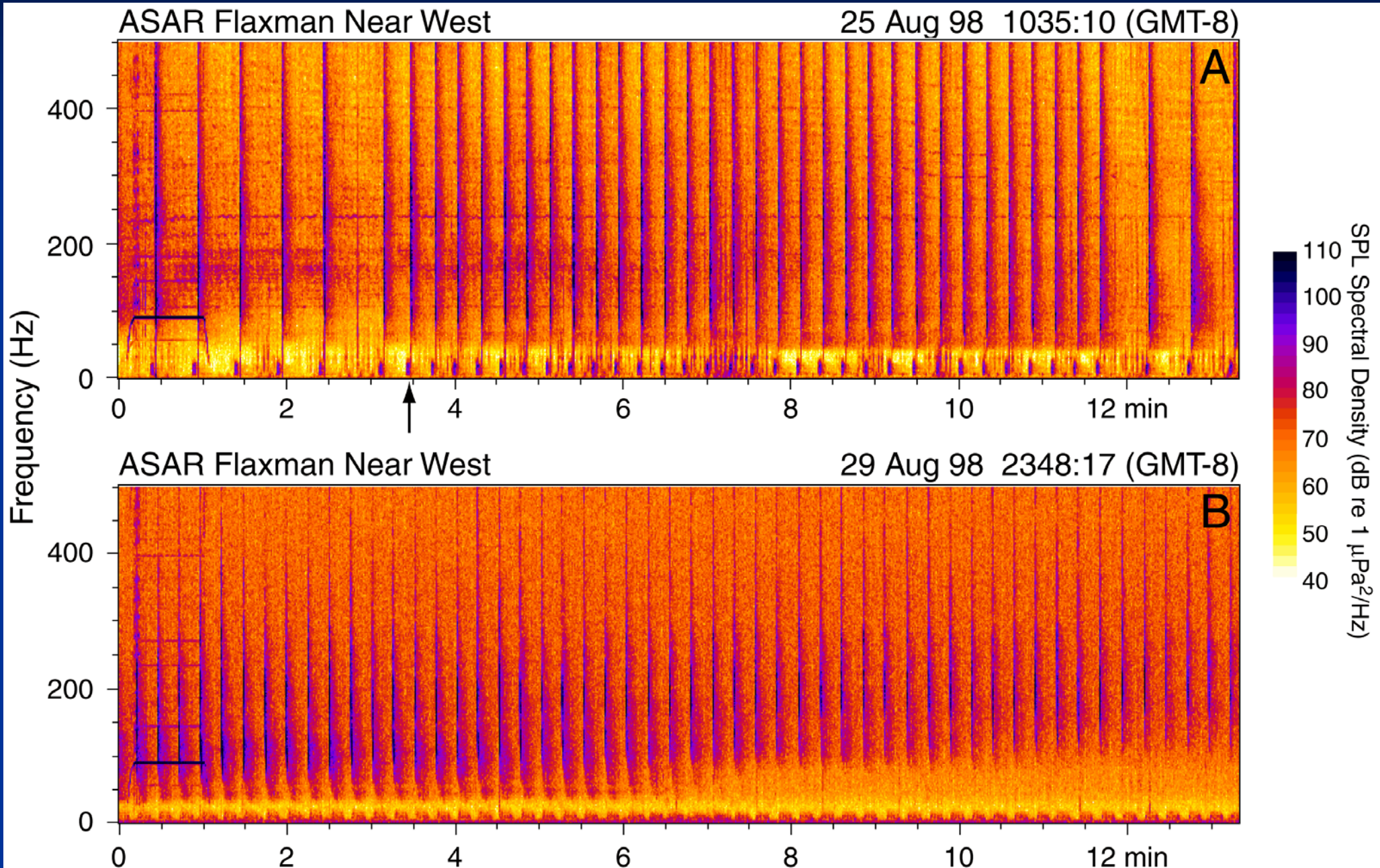



SUB-BOTTOM WAVES

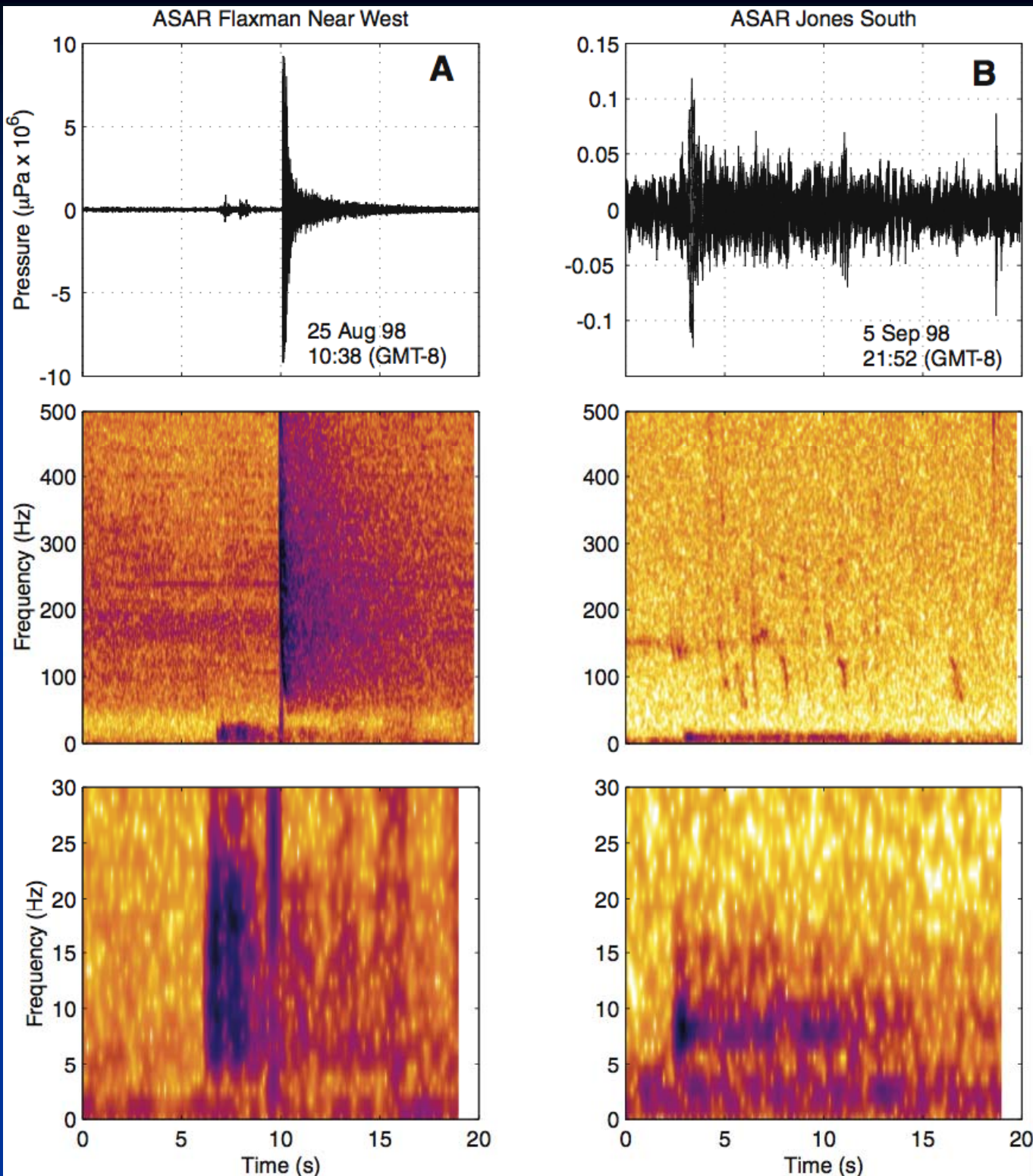



EXAMPLES OF WAVEGUIDE CUTOFF BEHAVIOR

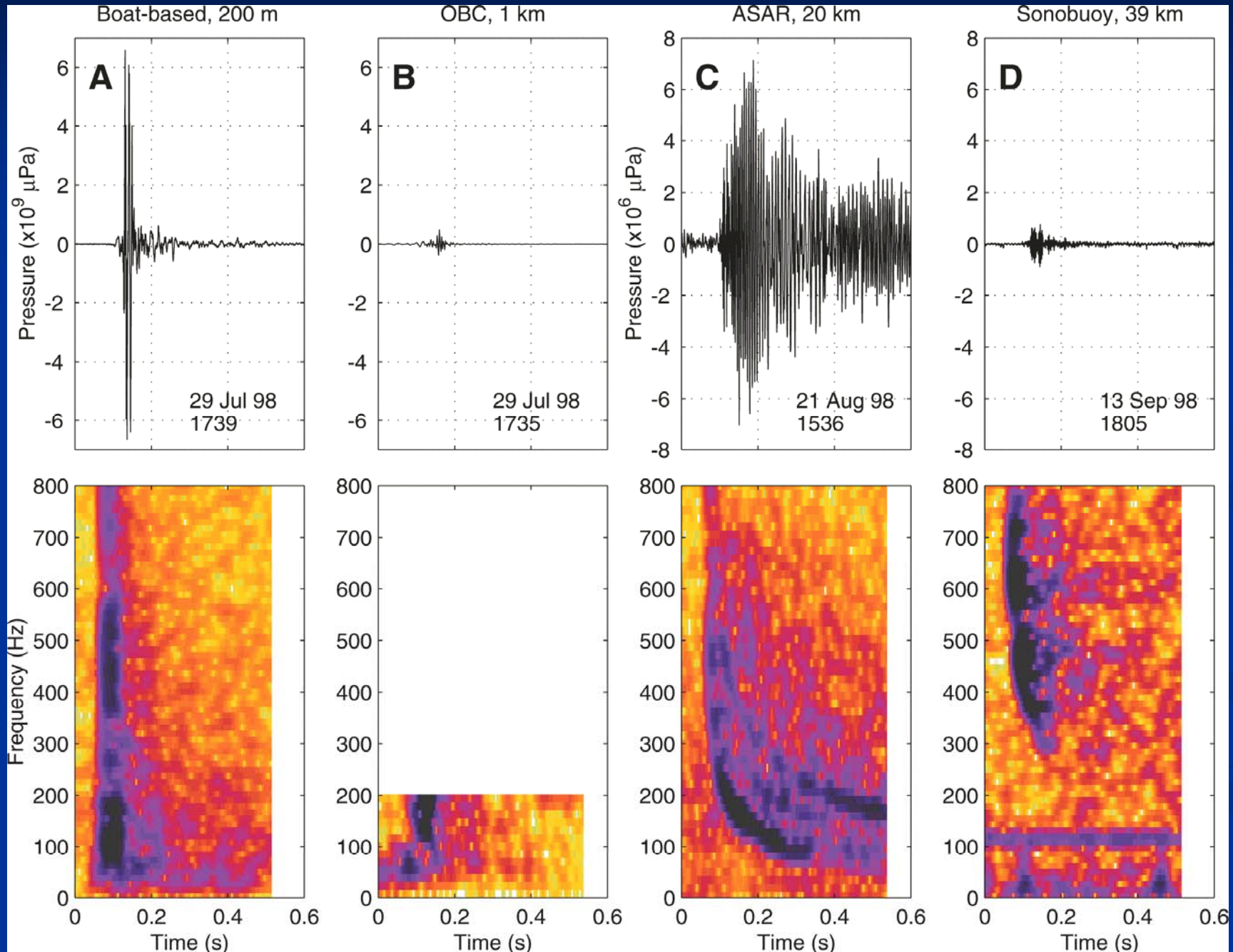



DOWN-SLOPE PROPAGATION

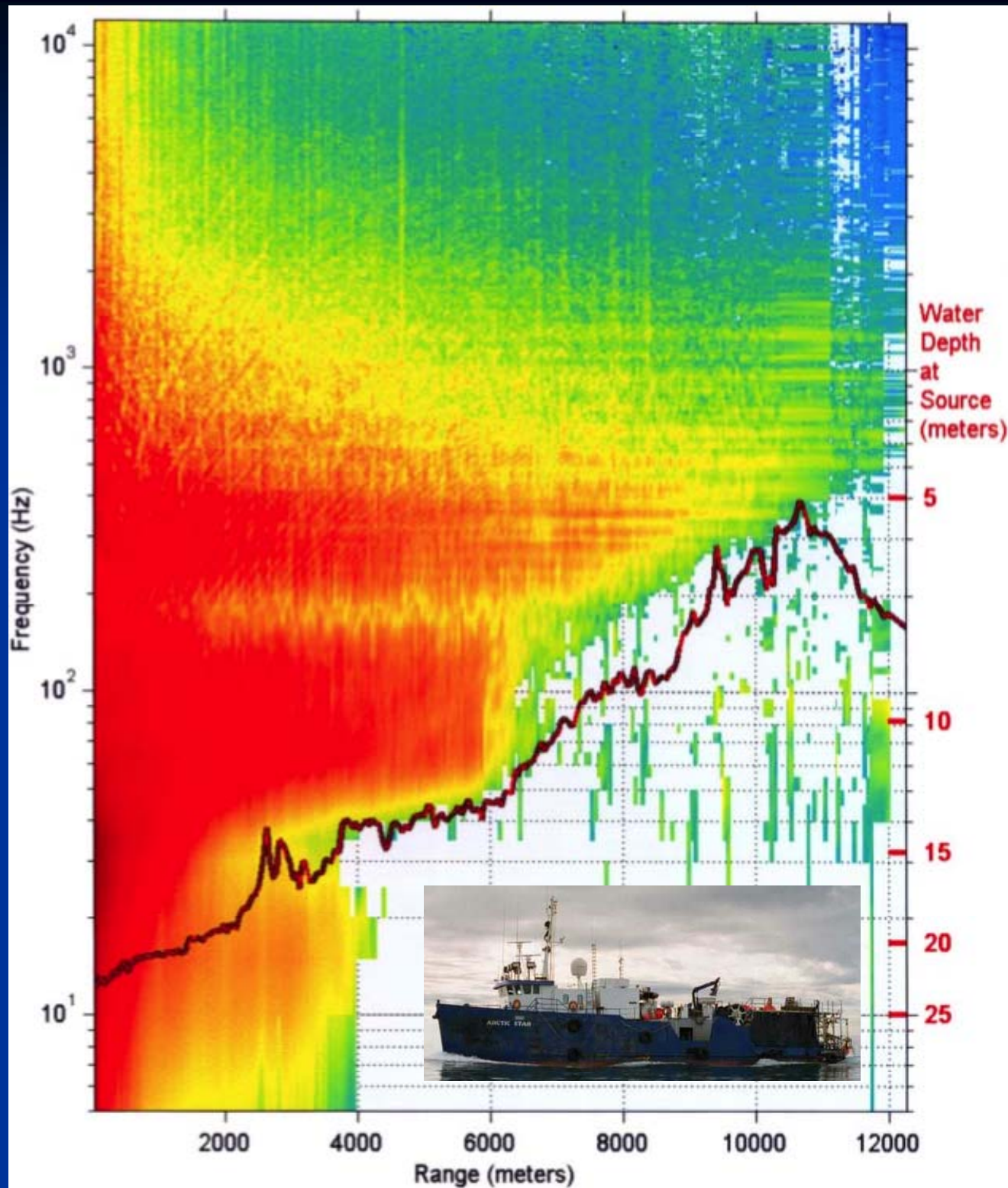

ESRF

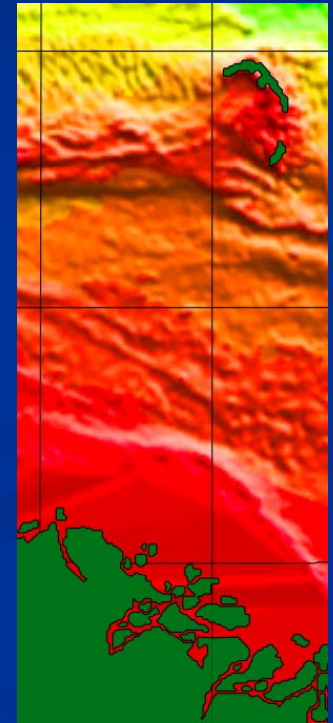



WATER DEPTH CAN AFFECT BOW vs. STERN ASPECT DEPENDENCE

ESRF

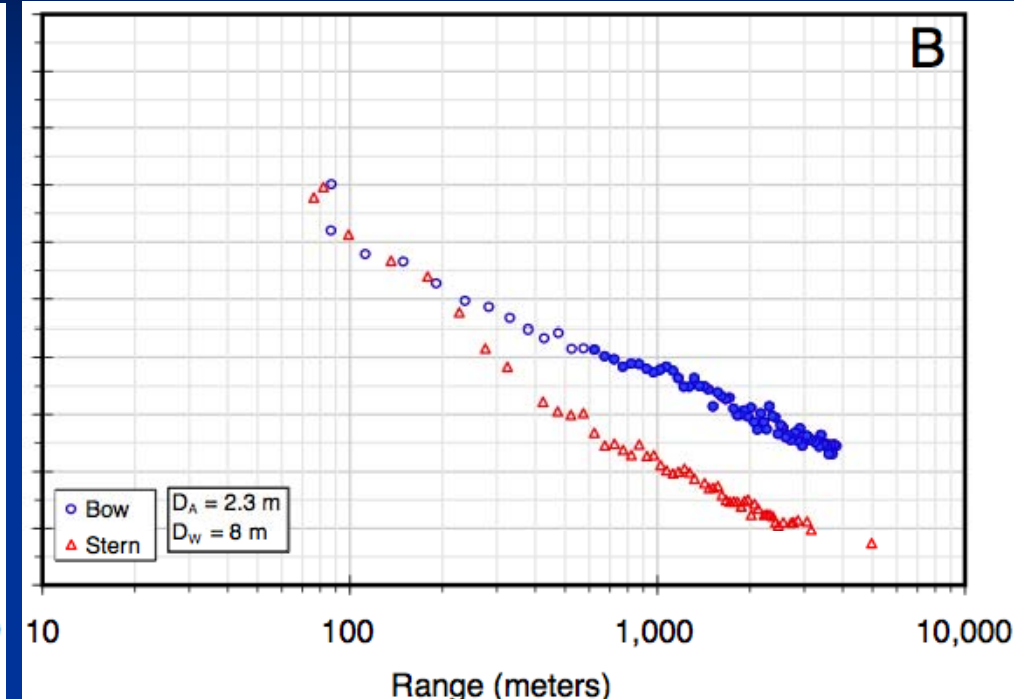
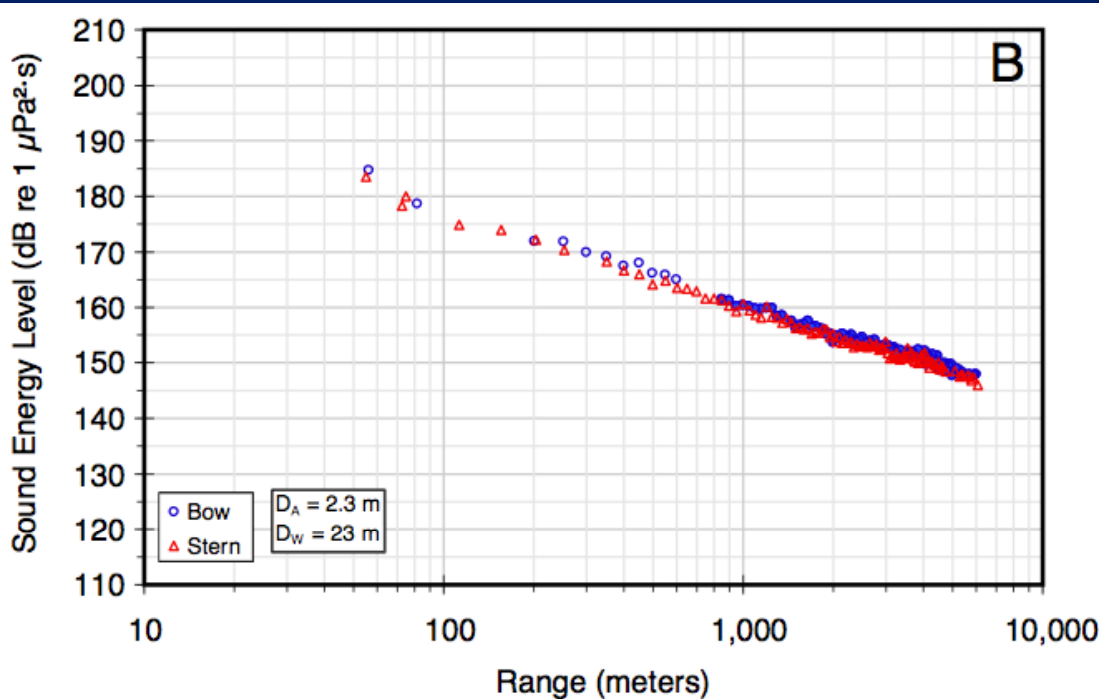

- Both over same track
- Track chosen for uniform depth (23 m)

- Both over same track
- Track chosen for uniform depth (8 m)



RELIC PERMAFROST

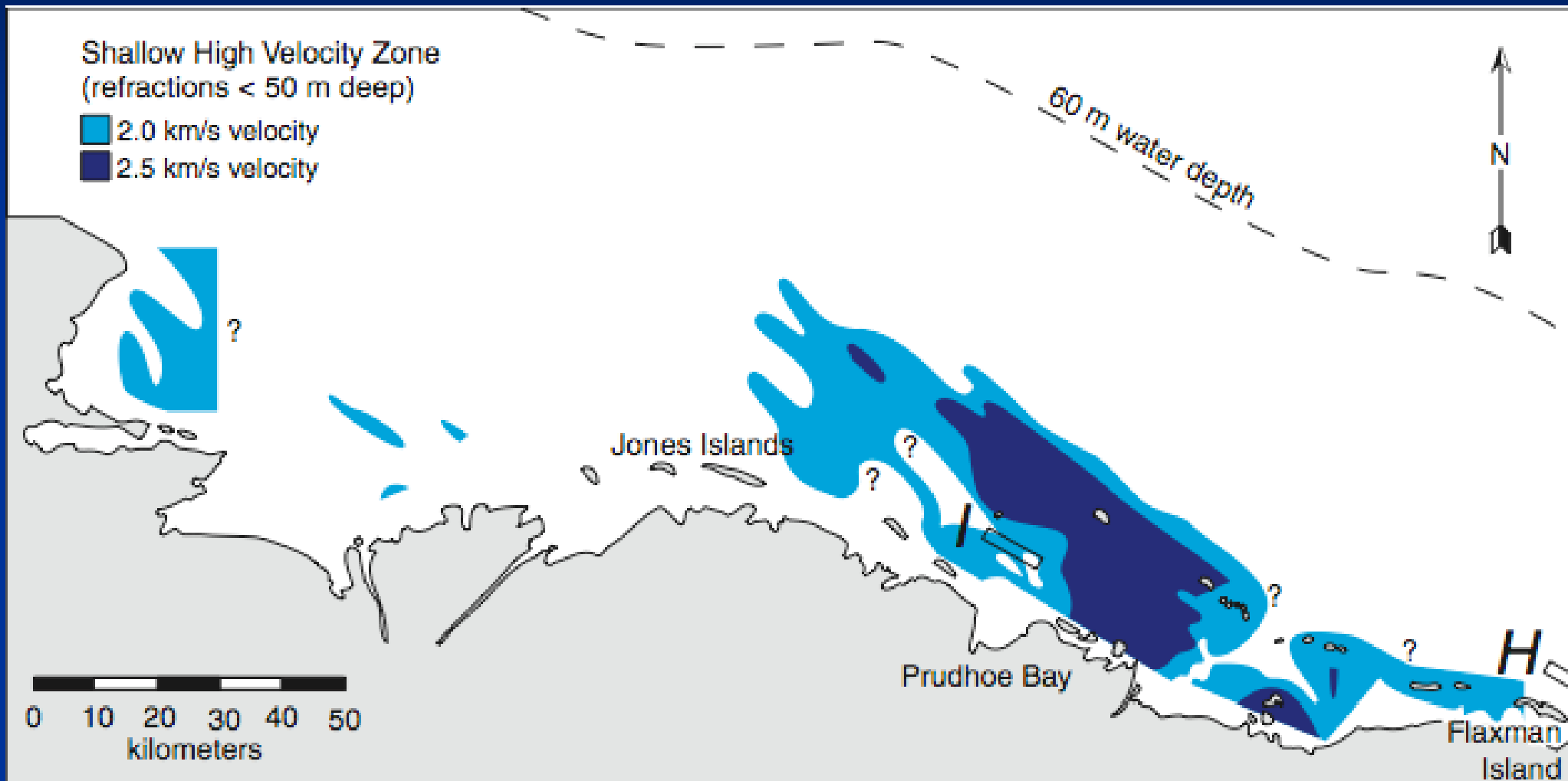



MODELED EFFECT OF RELIC PERMAFROST

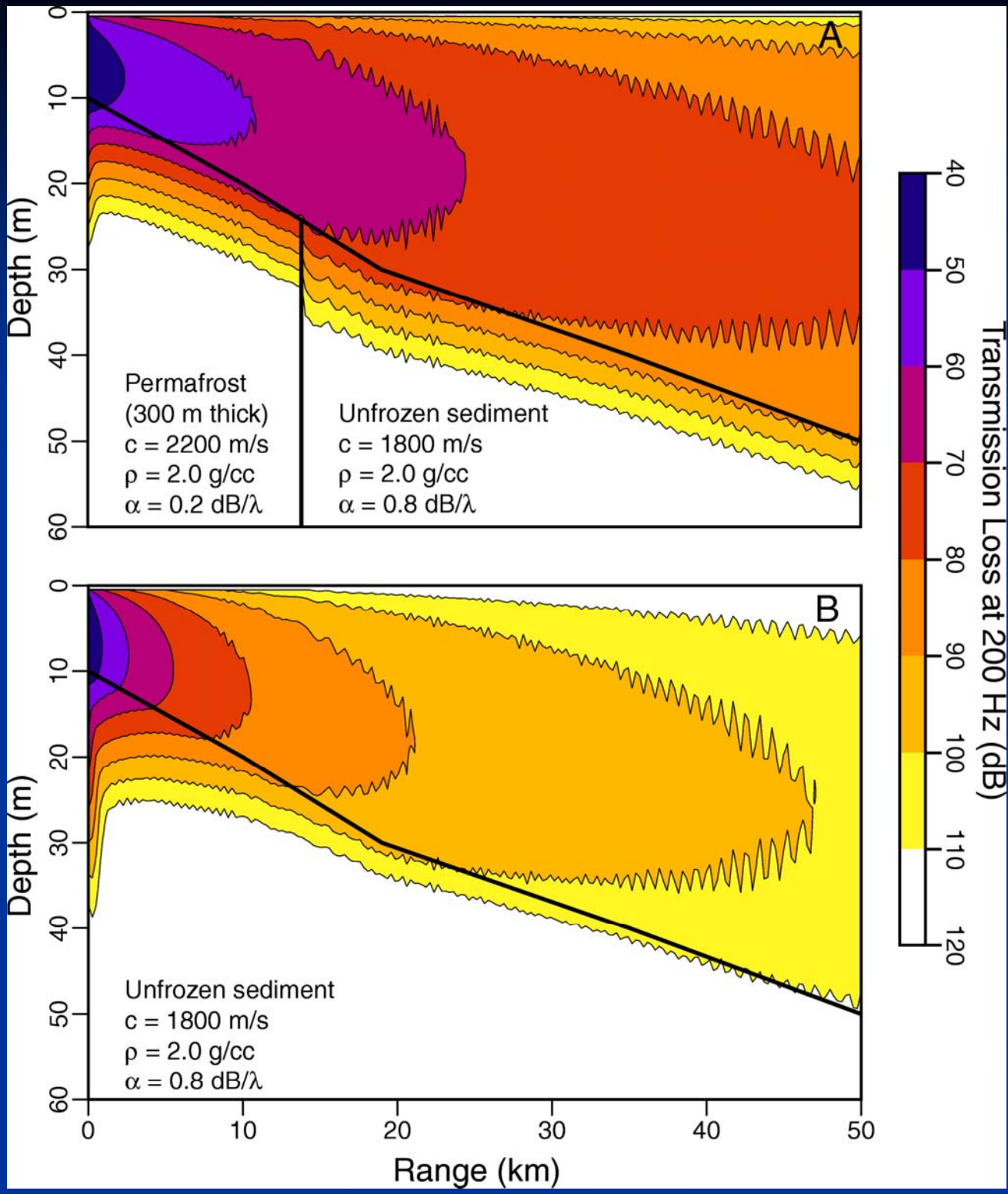



OCEAN-BOTTOM CABLE MAPPING OF SOUND FIELD

ESRF

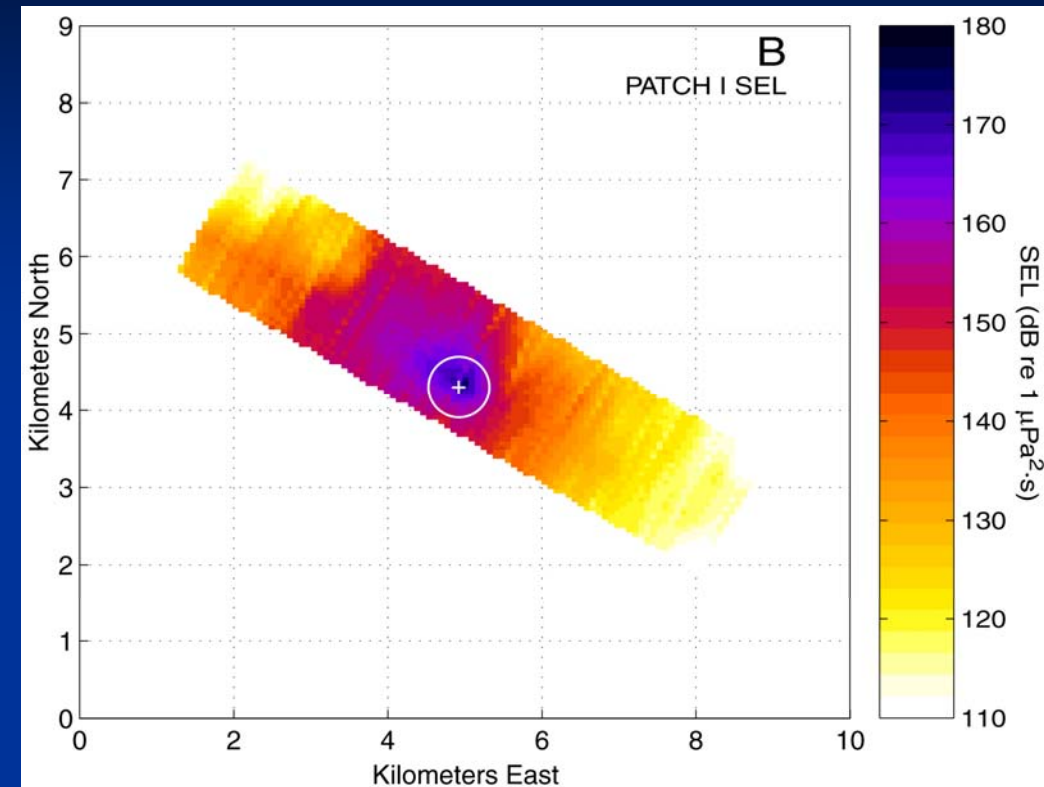
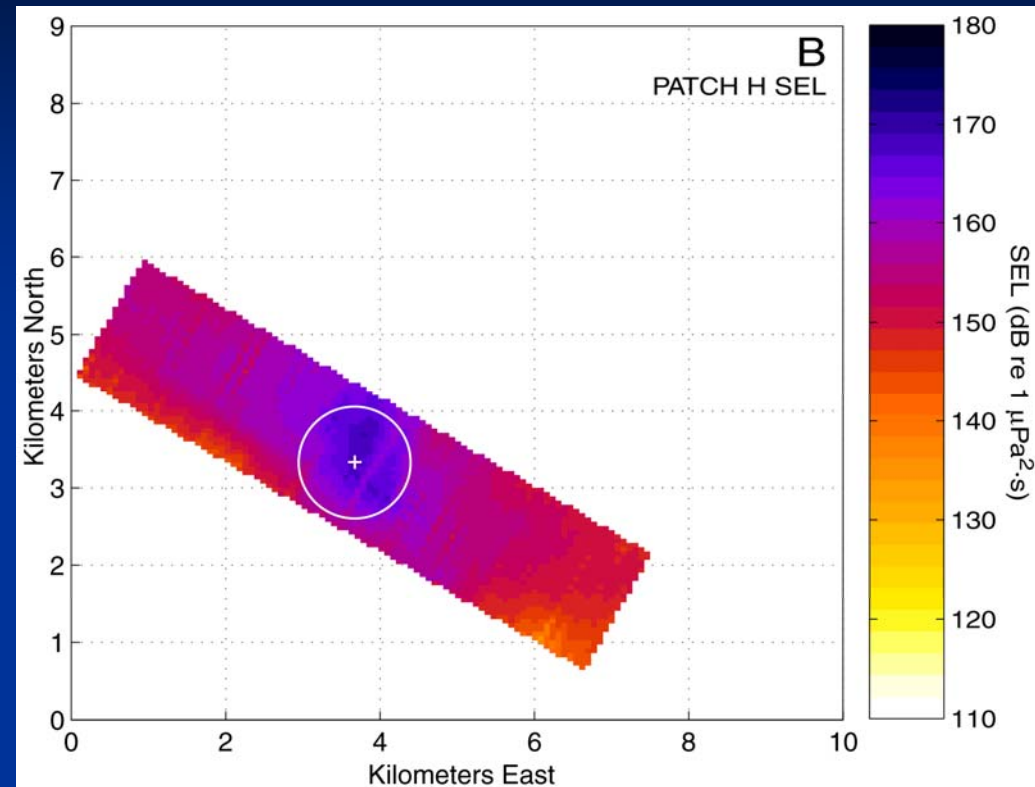

- 17-20 m deep
- No relic permafrost

- 6.5-7 m deep (5m in extreme SE corner)
- Relic permafrost present; N&S 1984 suggests located in center & West



CONCLUSIONS: COPING WITH VARIABILITY

- Bathymetry's effect on signatures as well as levels
 - Depth between source and receiver affects cutoff frequency and received pulse signature
 - Shallow water at source may increase bow/stern aspect dependence
- Ground waves may exist even without water-borne waves
- Relic permafrost may increase received levels
- Suggest use of “reference tracks” chosen for uniform propagation conditions to enable comparisons across sources

Sound Source Verifications: Procedural Issues in the Field and during Analysis

Presented by Susanna Blackwell



ESRF Workshop on Seismic Survey Sound
Propagation in the Beaufort Sea,
Calgary, Canada, 14-15 July 09

In the Field

- Maximum range
- Aspect dependence
- Optimum source track to obtain necessary data
- Recorder deployment vs. water depth
- Sampling frequency range



1. Maximum range

Measurements to ~ 30 km:
not enough!

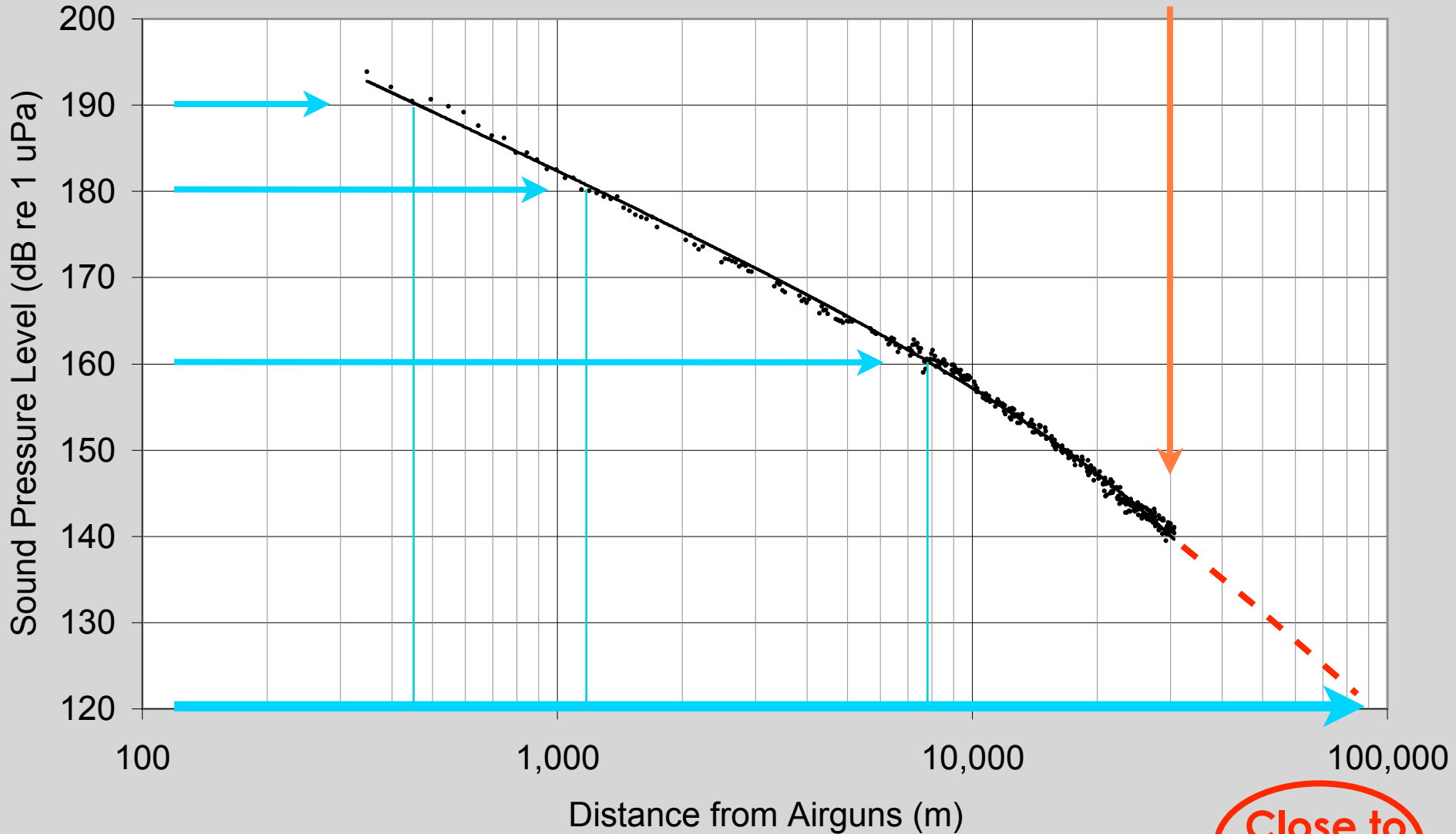

Close to
100 km

2. Aspect dependence

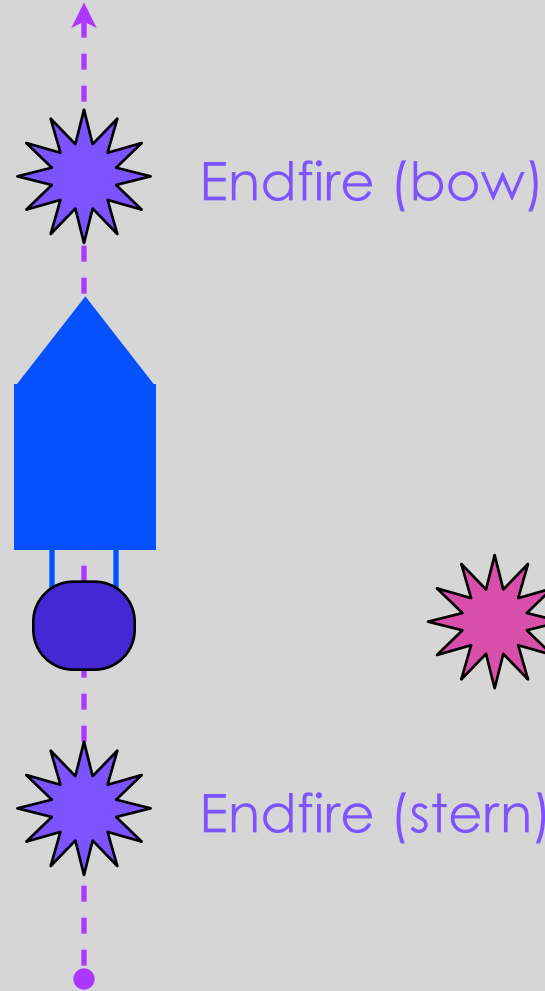

2. Aspect dependence

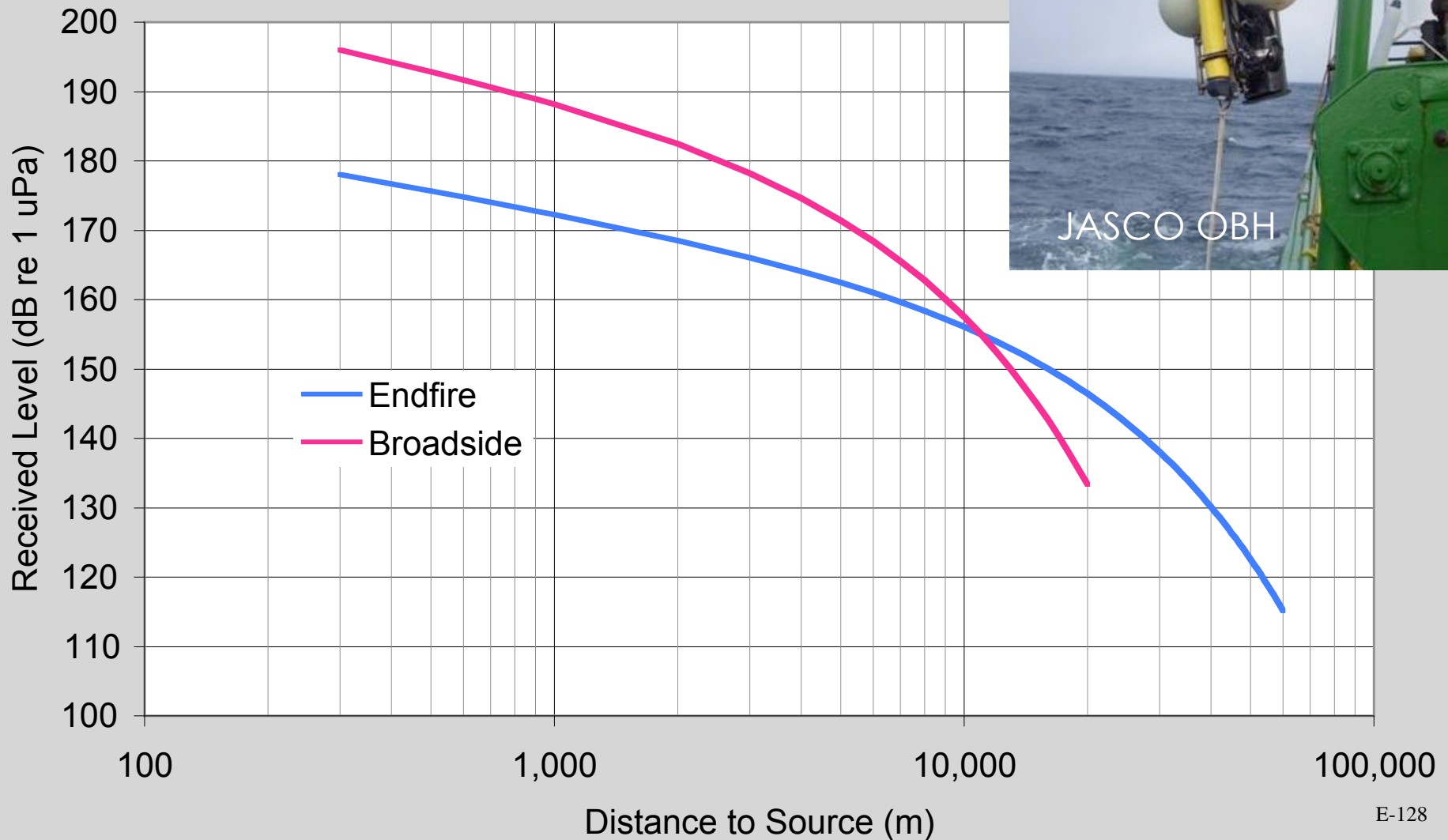

3. Optimum source track to obtain data

●● = Seafloor recorders (OBH, ASAR, etc.)

50 km

50 km



(drawing not to scale!)

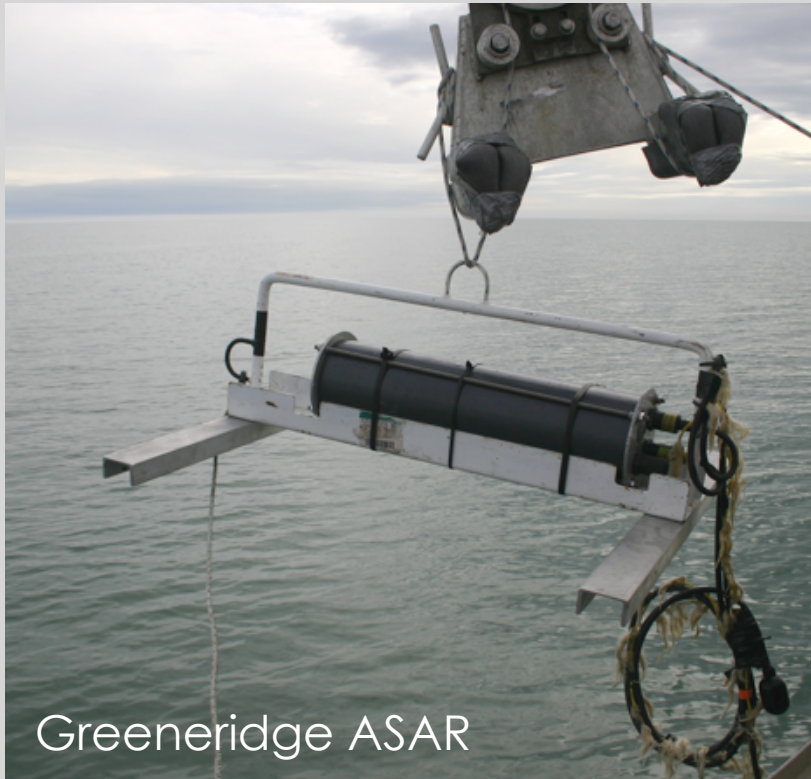

Greeneridge ASAR

● 100 km offline

=> endfire CPA to 100 km
=> broadside at 0.5 km, 2 km,
8 km, 100 km

4. Recorder deployment vs. water depth

(don't miss out on the nearfield)

Water depth: 10's of meters

100's of meters

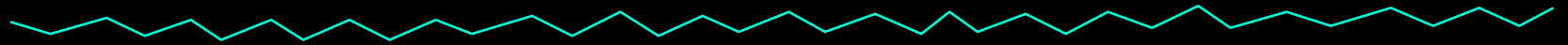

float
hydrophones



recorder



anchor

SEAFLOOR

5. Sampling frequency range

- Airgun pulses: most emitted energy below 150 Hz (higher f : weak compared to LF energy strong compared to background!)
- Therefore choice of frequency range mainly dependent on hearing range of animal of concern





During Analysis

- Discrepancies between field vs final reports
 - Pulse analysis method
 - Curve-fitting issues
 - Frequency weighting
 - SEL vs SPL and relationship between the two

2. Pulse analysis: using a good standard

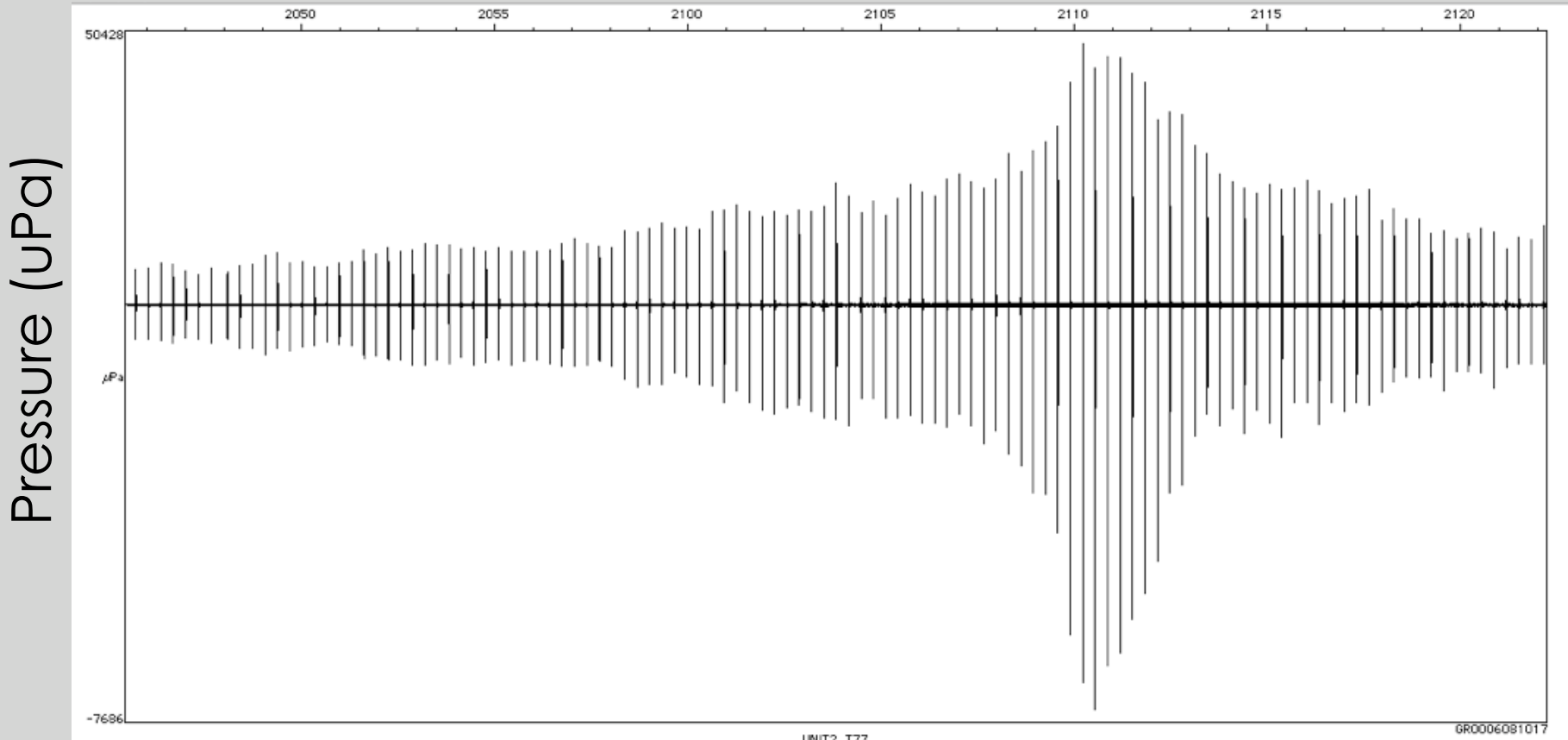

Time (35 min shown)

2. Pulse analysis: using a good standard

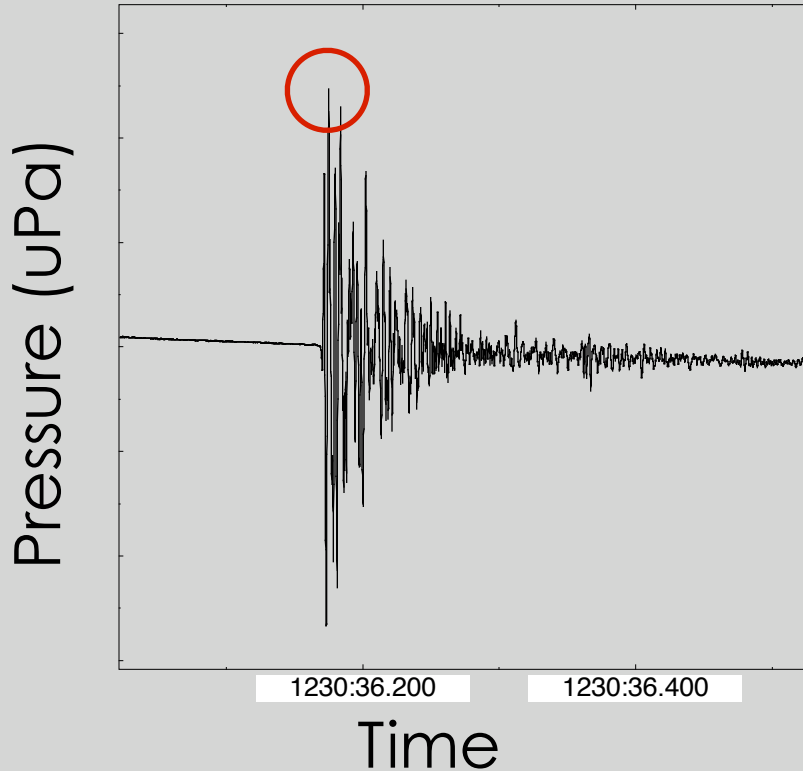

How to analyze?

- peak pressure only (incomplete)
- root mean square (SPL) => over what duration???

2. Pulse analysis: using a good standard

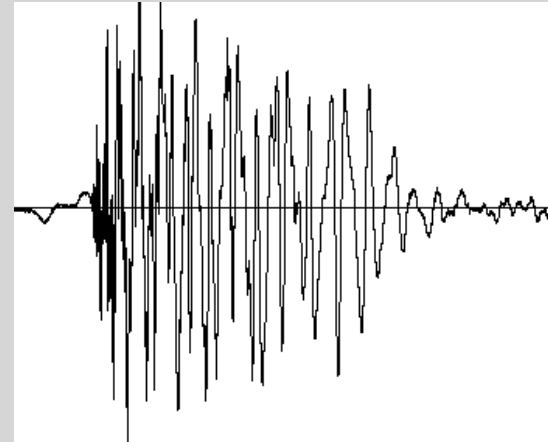
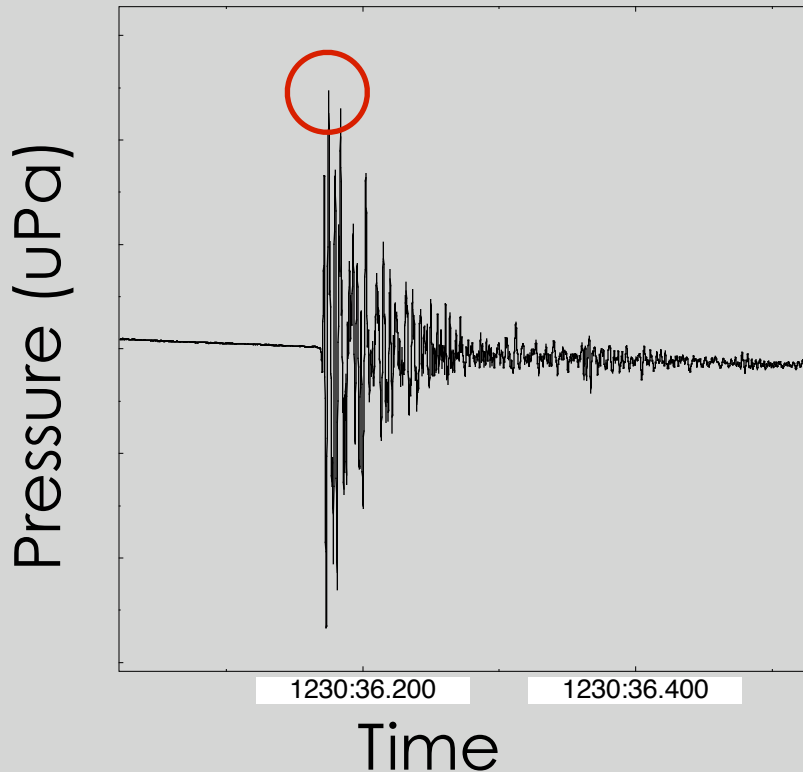

How to analyze?

- peak pressure only (incomplete)
- root mean square (SPL) => over what duration???

2. Pulse analysis: using a good standard

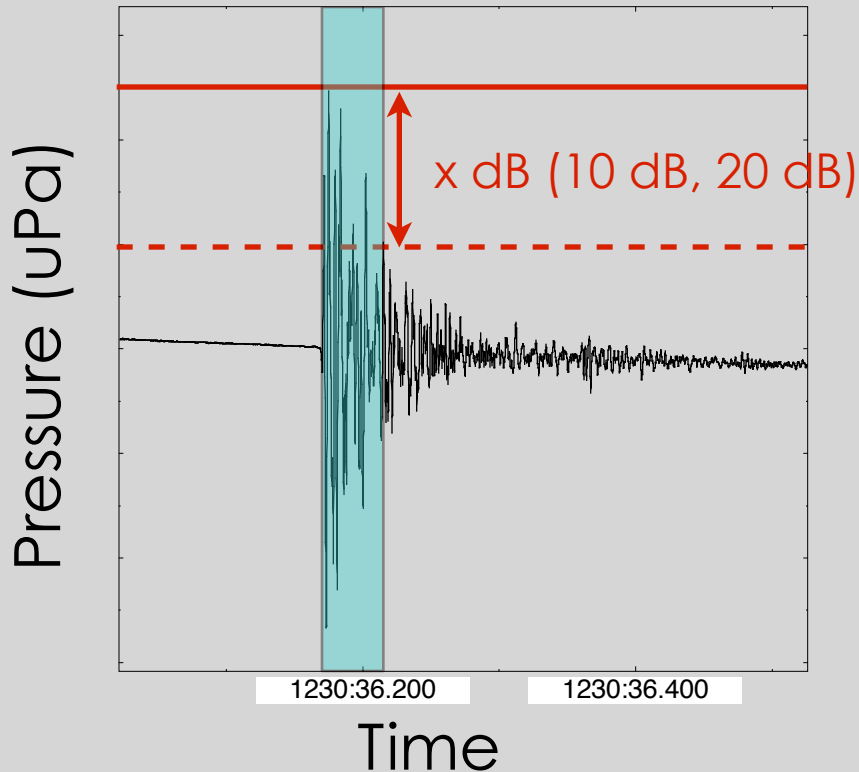

How to analyze?

- peak pressure only (incomplete)
- root mean square (SPL) => over what duration???
- peak minus x dB to define duration

2. Pulse analysis

- peak pressure
- duration
- SPL (- background)
- SEL (- background)

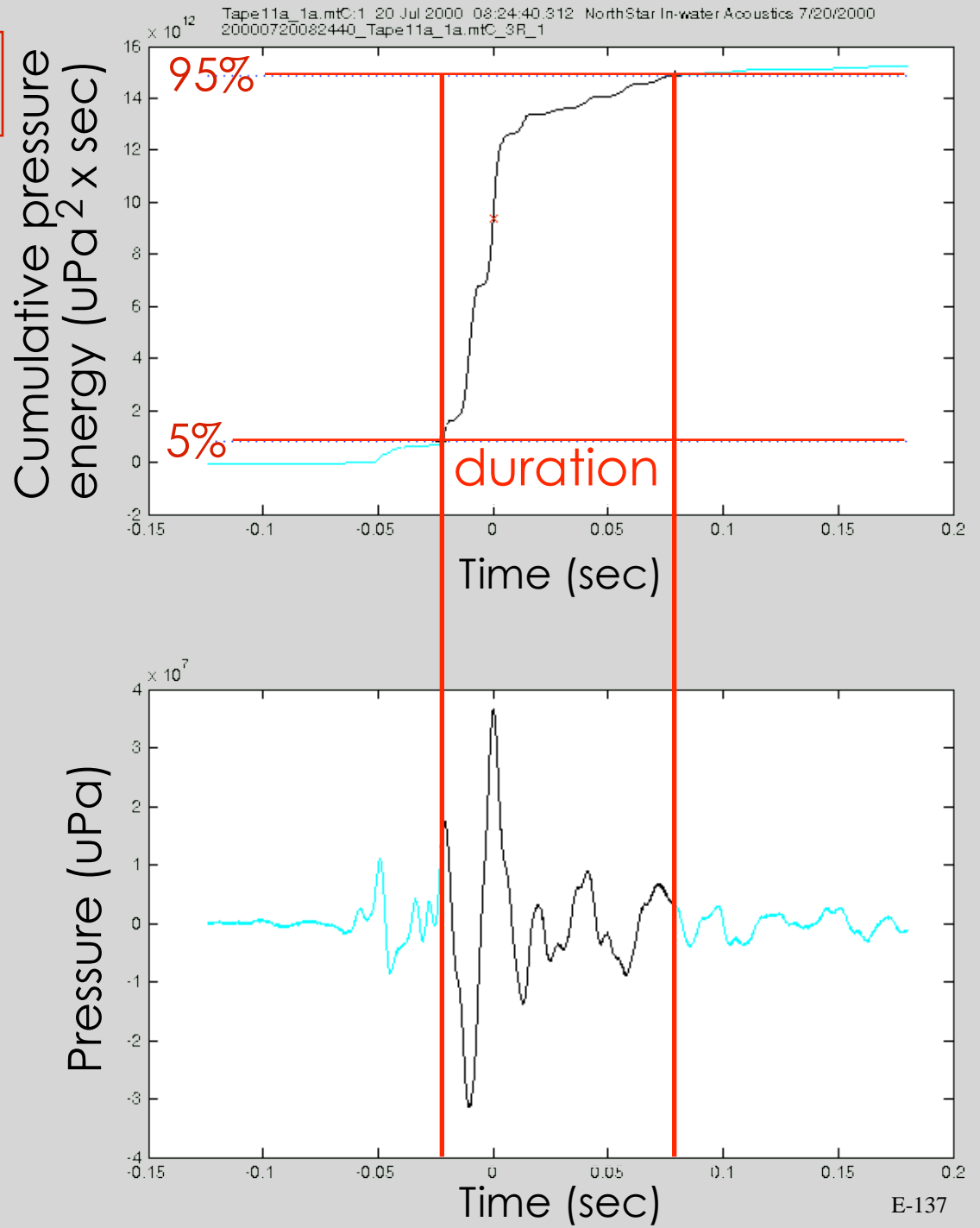

3. Curve-fitting issues



3. Curve-fitting issues

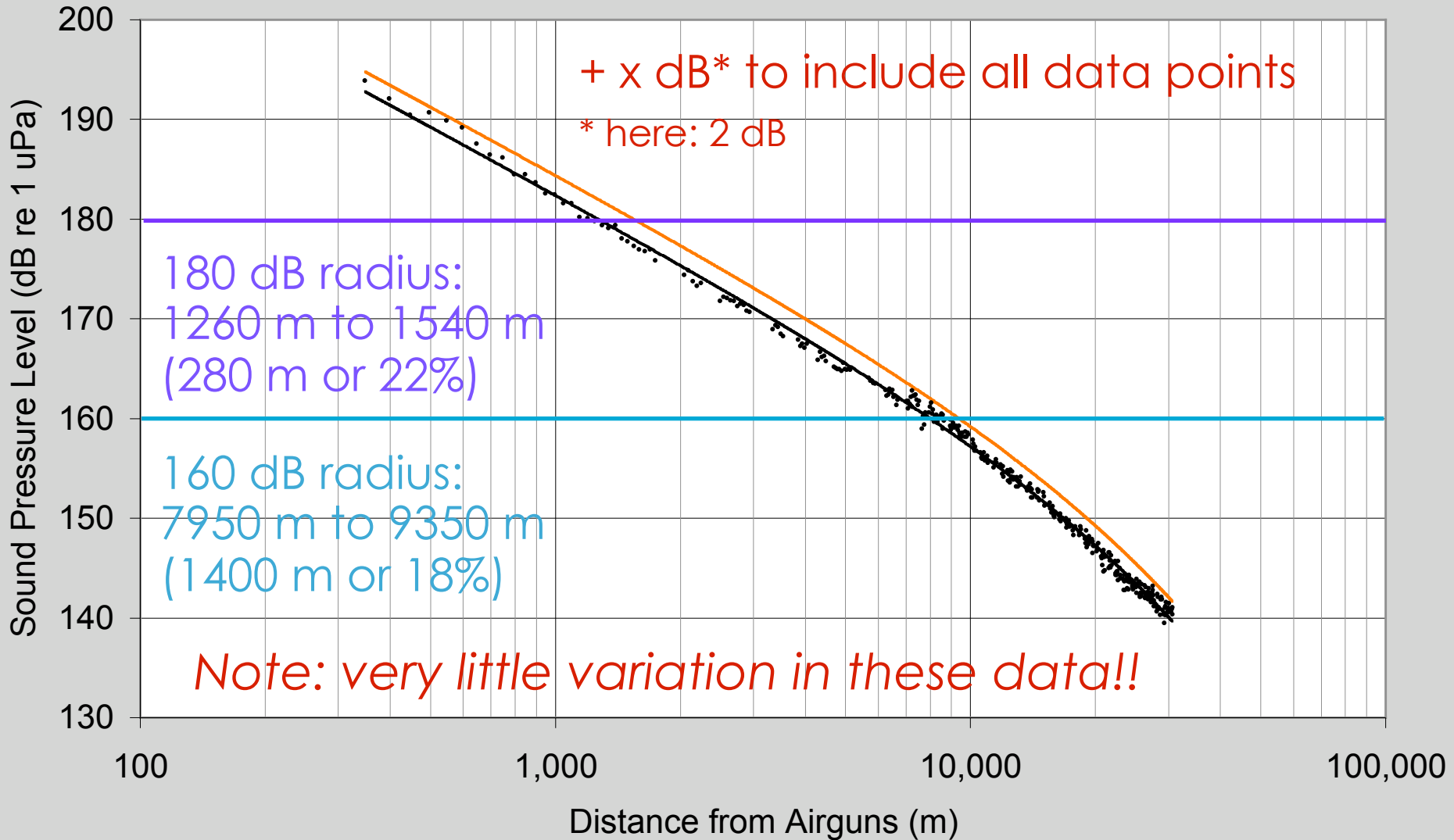

3. Curve-fitting issues

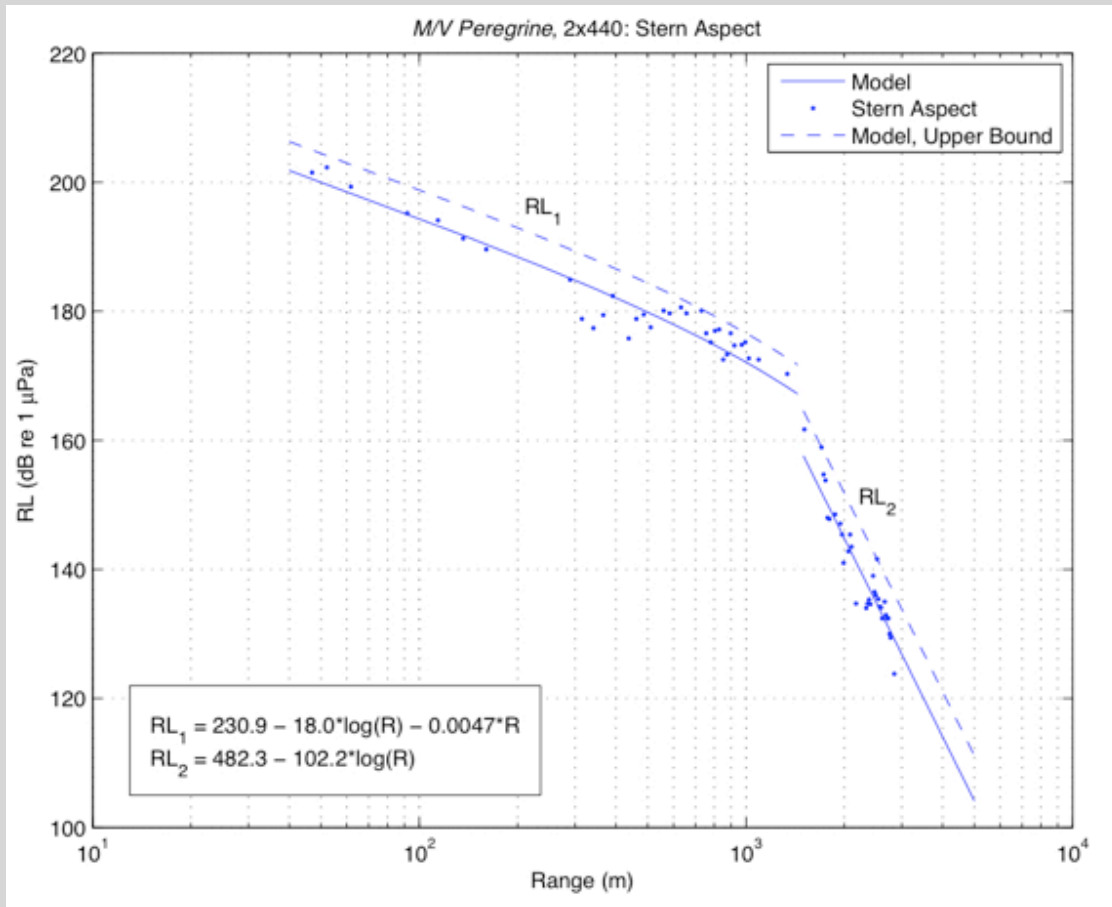

Break in RLs at ~ 1.5 km:
marked change in
bottom stratigraphy /
composition --
also visible in seismic
acquisition data

4. Frequency weighting

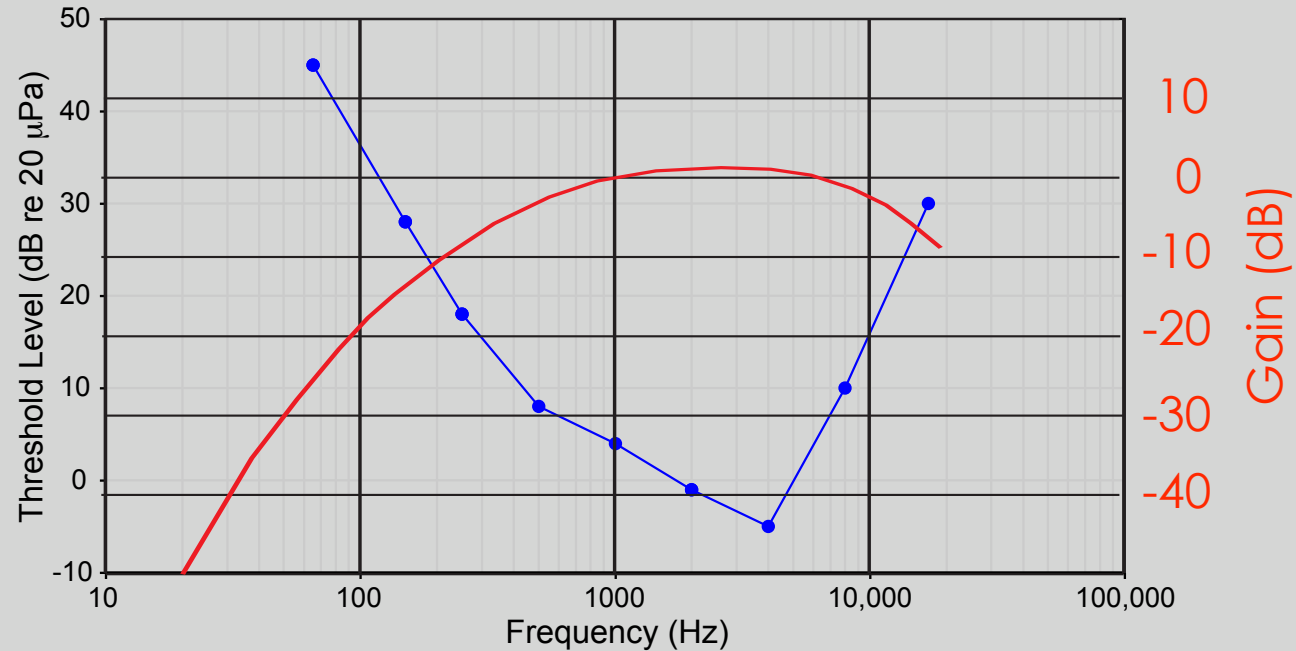

Human
audiogram (in
air)

A-weighting
curve

Ways to do this:

- Subacoustech: $dB_{ht}(\text{species})$ metric = “passing the sound through a filter that mimics the hearing ability of the species”.
- $dB(A)$ scale = $dB_{ht}(\text{Homo sapiens})$

DISADVANTAGE:

- you need an audiogram for each species!
- not really suitable for high intensity sounds

4. Frequency weighting

Southall et al: functional hearing groups:

Audiograms of Selected Odontocetes

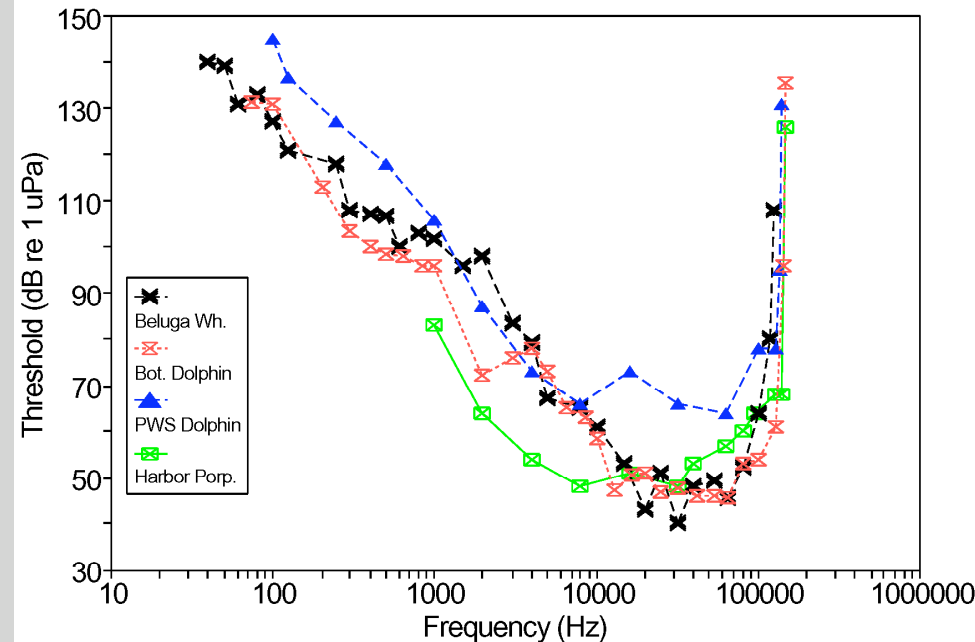

Underwater Audiograms of Pinnipeds

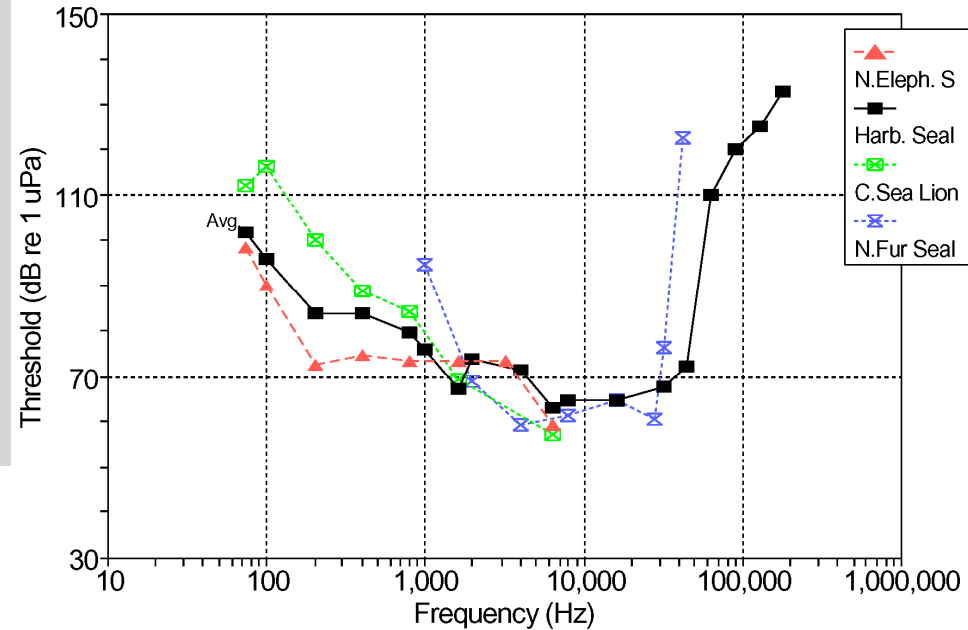

4. Frequency weighting

Southall et al: functional hearing groups:

- LF Cetacean: baleen whales (estimated)
- Pinniped in air
- Pinniped in water
- MF Cetacean: most toothed whales
- HF Cetacean: river dolphins, porpoises

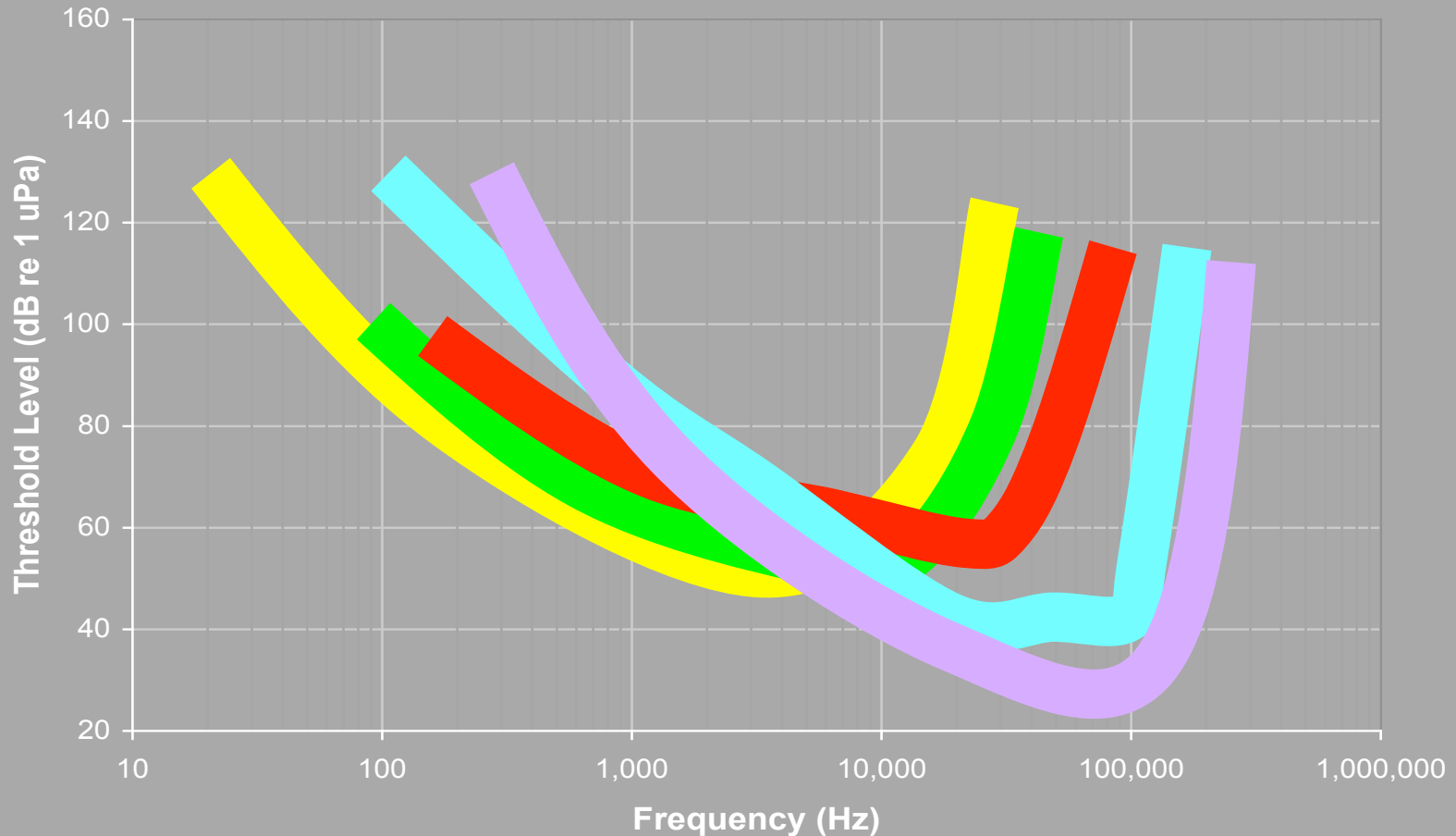

4. Frequency weighting

M-weighting curves:

Pinnipeds:
underwater - flow 75 Hz, fhigh 75 kHz
in air - flow 75 Hz, fhigh 30 kHz

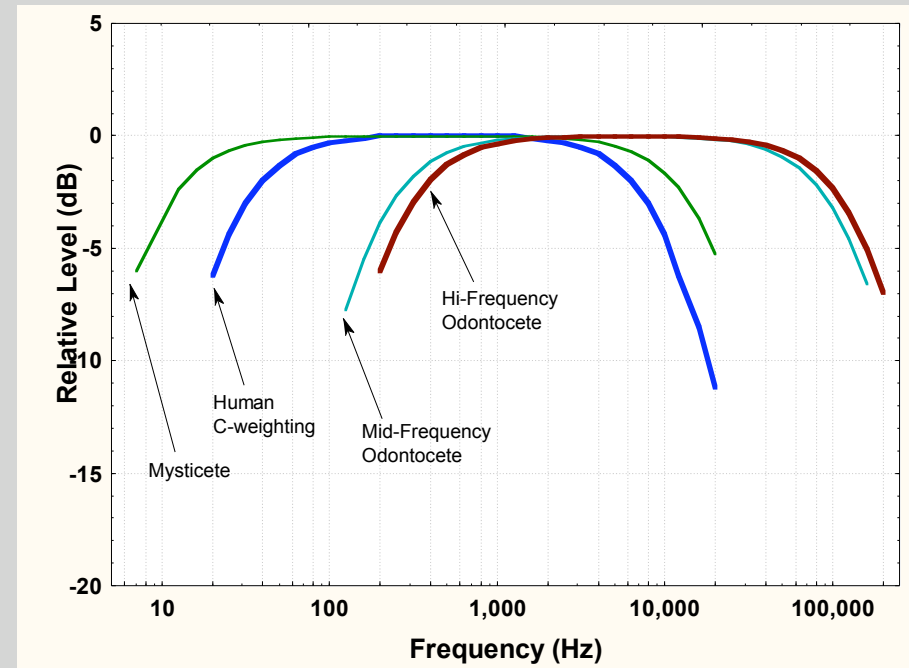
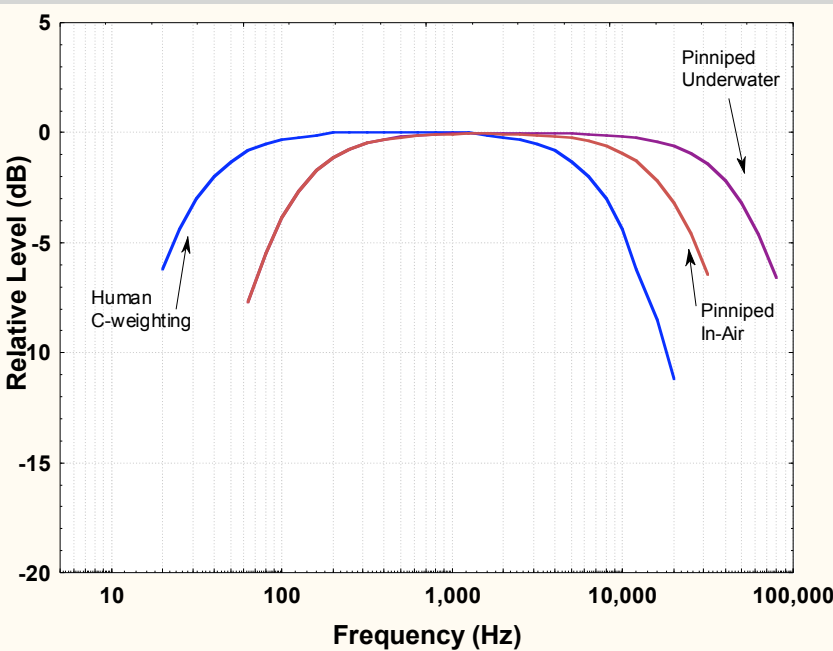

Cetaceans:

LF - flow 7 Hz, fhigh 22 kHz

MF - flow 150 Hz, fhigh 160 kHz

HF - flow 200 Hz, fhigh 180 kHz

5. Relationship between SPL and SEL

What's she doing, subtracting apples from oranges????

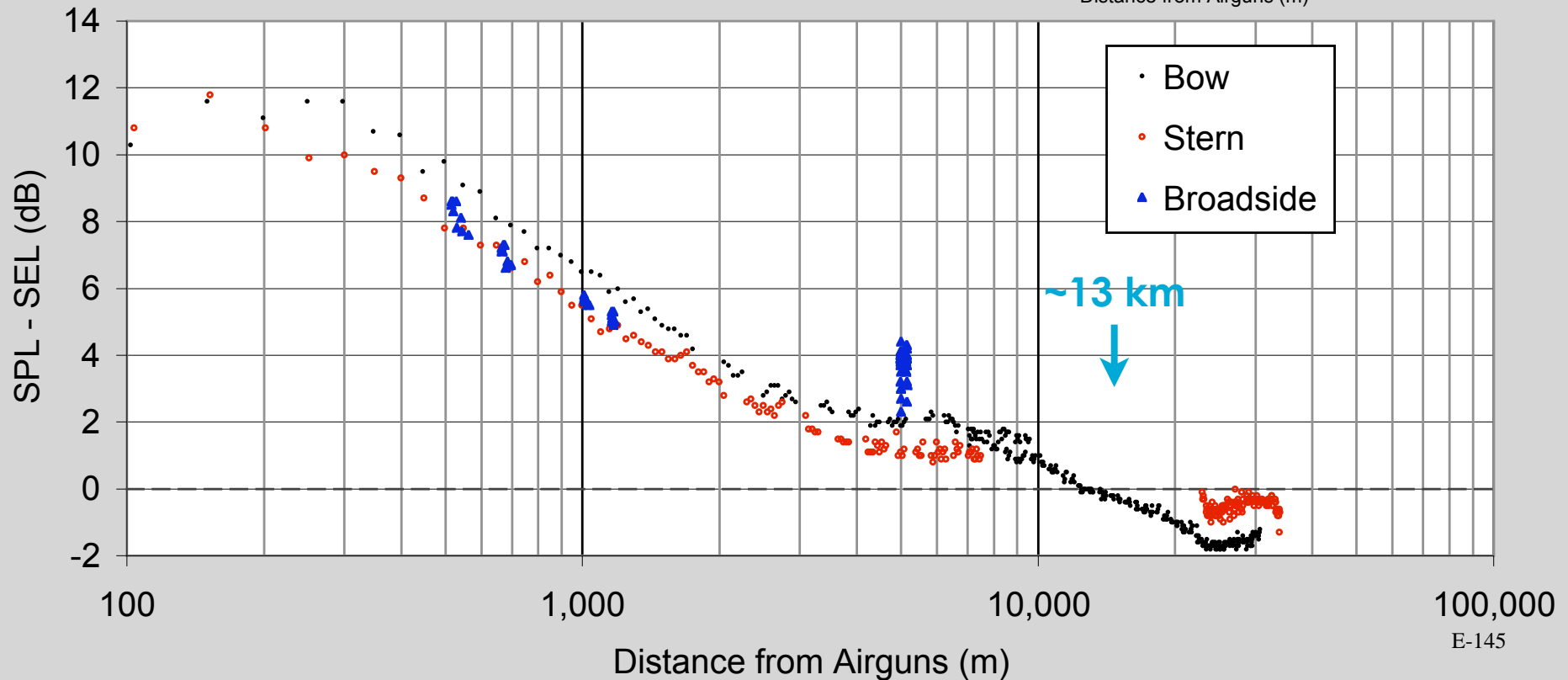
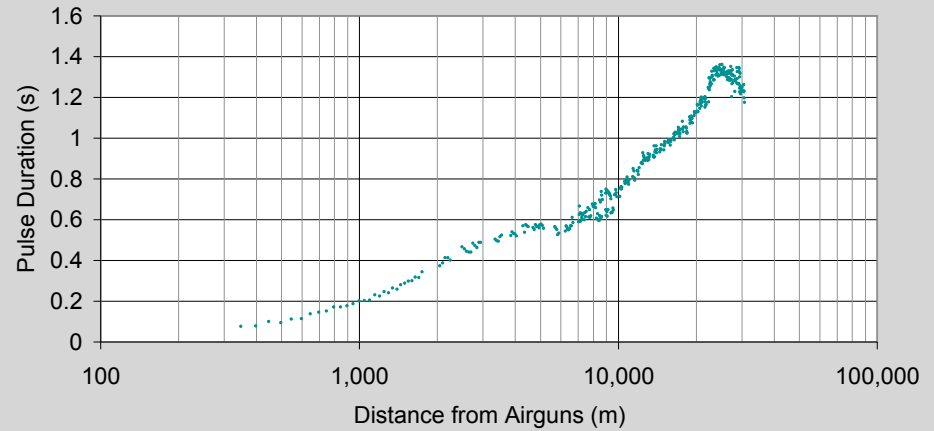

Summary

- Maximum range: consider up to 100 km depending on goals.
- Aspect dependence: endfire AND broadside data must be obtained - importance of recorder layout.
- Sampling frequency: 8-16 kHz sufficient for RL but not for assessing what animal of interest hears.
- Pulse analysis: use “5%-95%” method, SEL / CSEL but continue computing 90% SPL for comparative purposes?
- Curve-fitting: use best-fit (median) AND 95th percentile?
- Frequency-weighting: M-weighting for now, species-specific when data available?



Model-Data Comparison

David Hannay



Overview

- **Comparisons of pre-season model predictions of Peak, RMS and SEL levels for GXT's 2007 Beaufort program.**
- **Comparison of the water velocity profiles used for modeling with those obtained from CDT's during the field measurements.**
- **Summary of model performance.**

250 m Pre-season velocity profile versus CTD

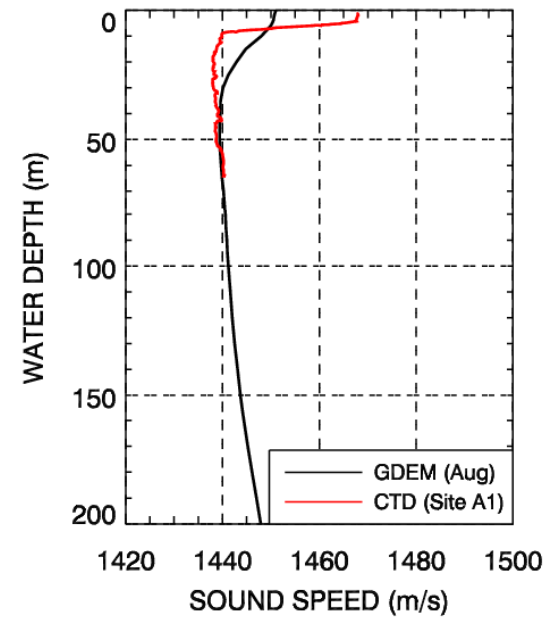
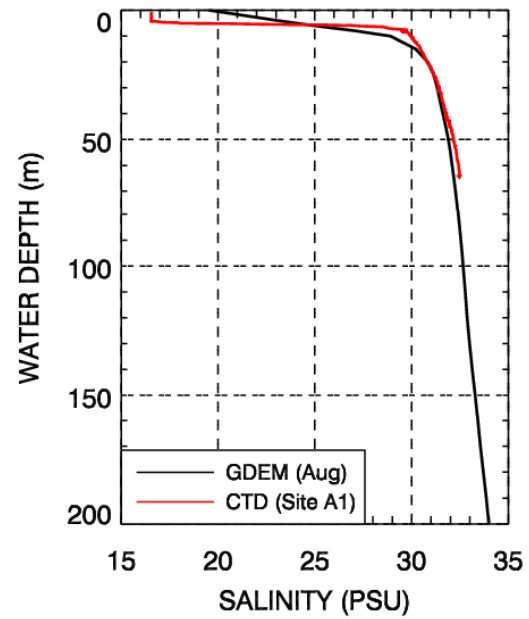
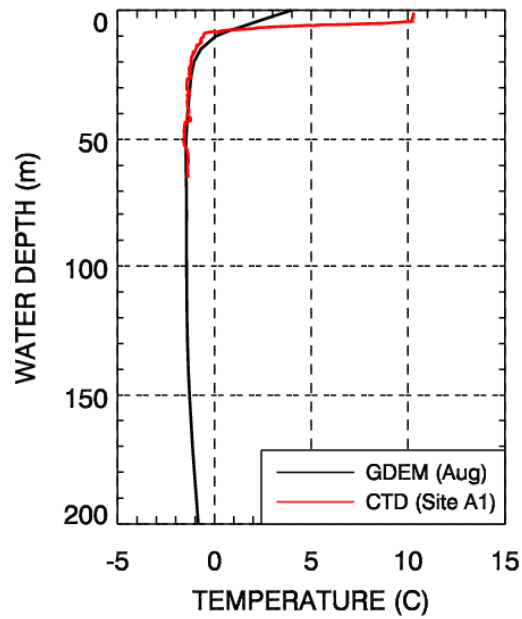

Pre-season modeling versus field data

- 250 m water depth

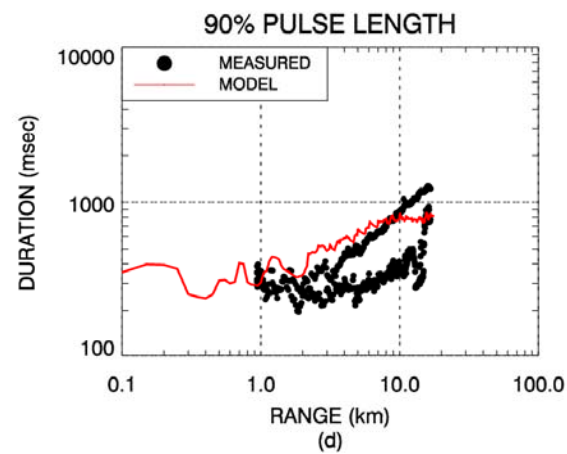
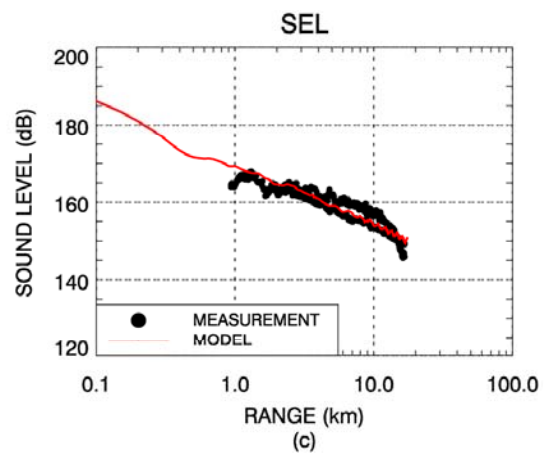
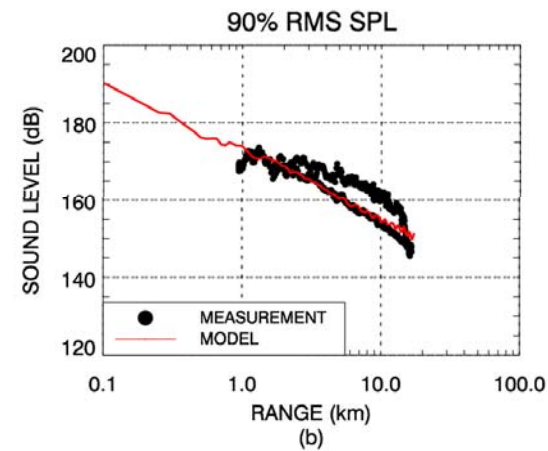
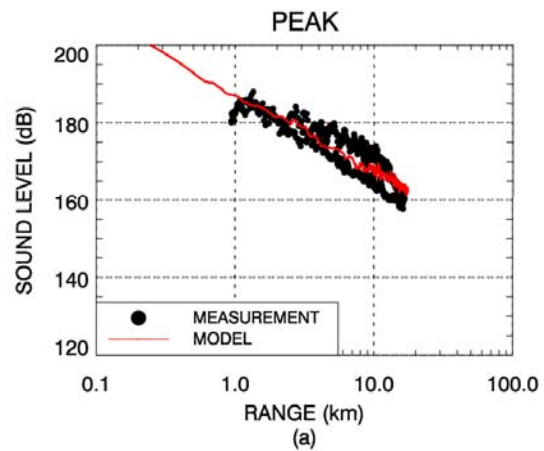

Pre-season velocity profile versus CTD

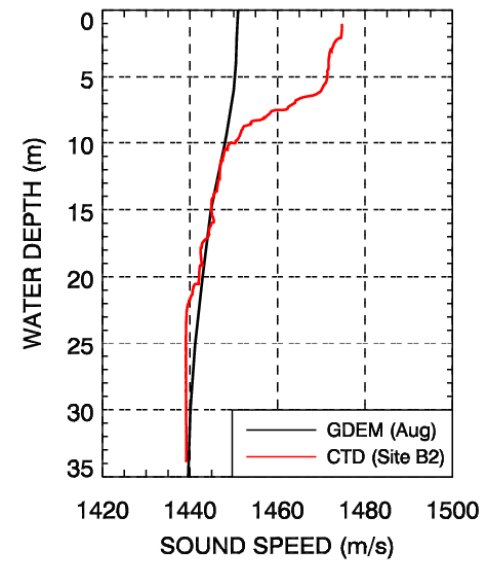
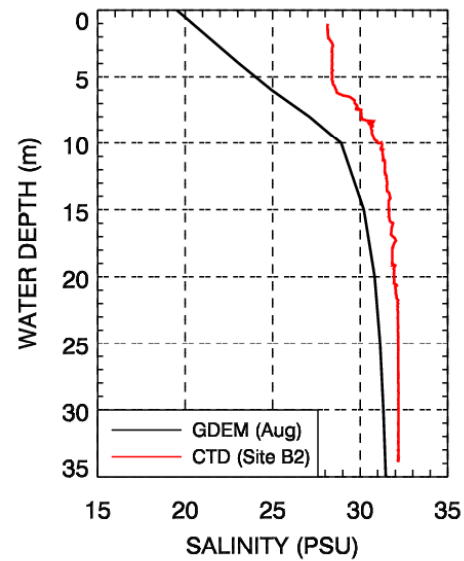
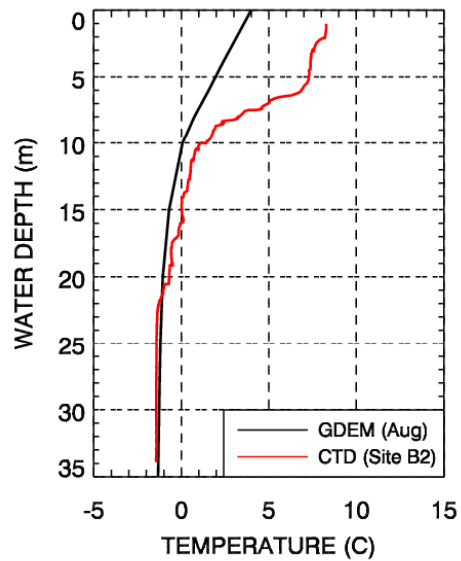

Pre-season model versus field data

- 30 m depth

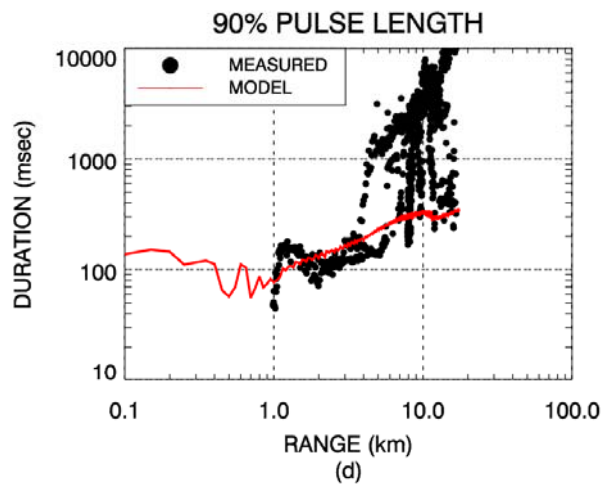
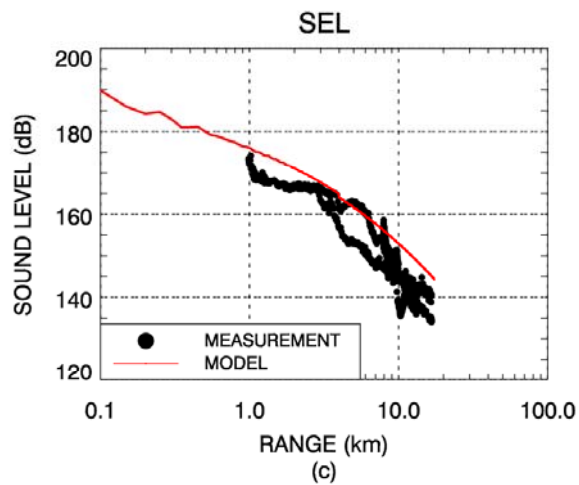
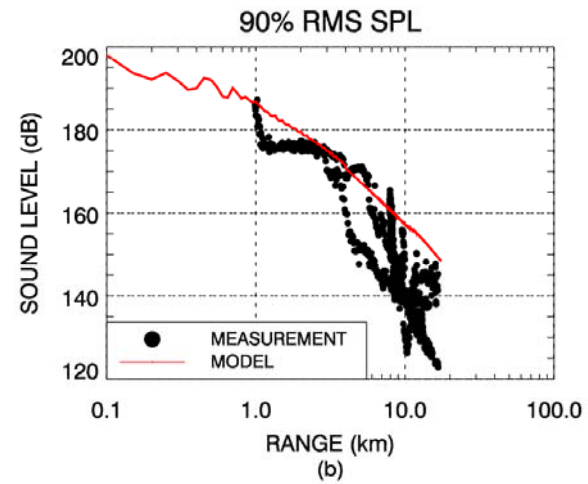
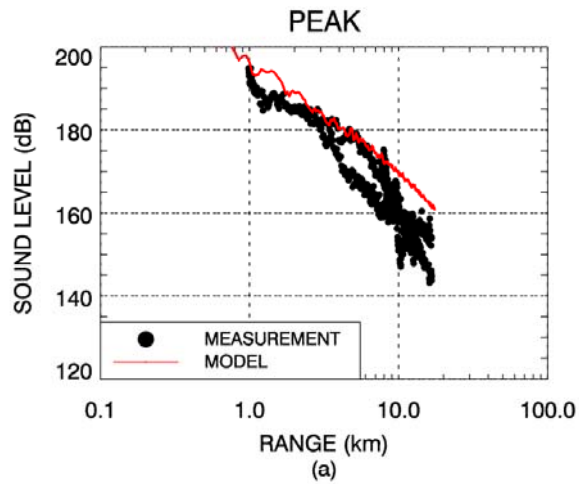

To summarize

- Make sure to model at depths expected to be monitored during verification measurements (e.g. include bottom depth in model if using bottom-moored recorders).
- Pre-season modeling produced fairly accurate predictions of peak, RMS and SEL metrics.
- SEL predictions more accurate than RMS.
- Pulse length predictions good at short range but underestimating measured values at long ranges.

Pre-Season Modeling - Empirical Comparisons

Sakhalin Experiences

Mike Jenkerson

ESRF Workshop: Seismic Survey Sound Propagation in The Beaufort Sea
14th-15th July 2009

Odoptu Acoustic Data - Northern Transect - 5 August 2001
7 km Offset Line - 20 m hydrophone depth - Sonobuoy [T.4]

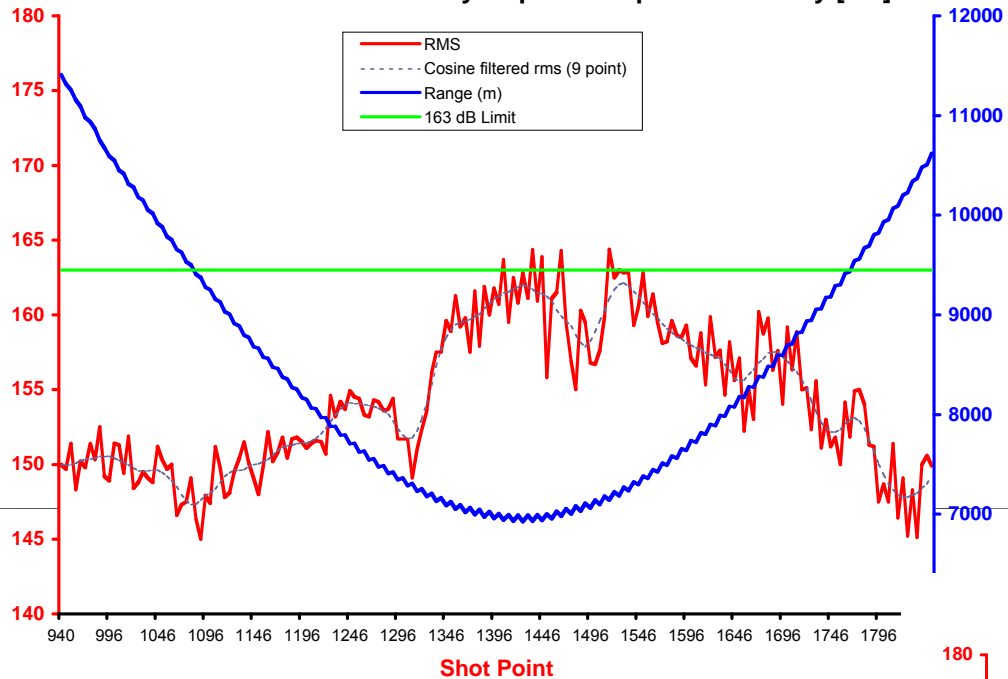

Acoustic Data - Northern Transect - 12 August 2001
4 km Line - 20 m Sonobuoy [T.4]

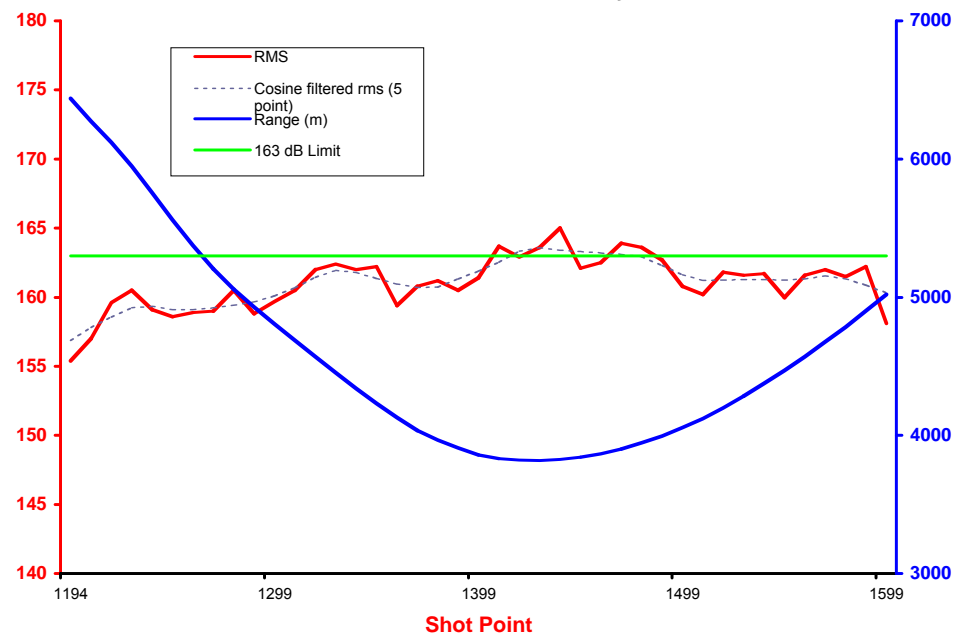

Source Directivity Plot - azimuth : 0.0 degrees - array odoptu_test_6

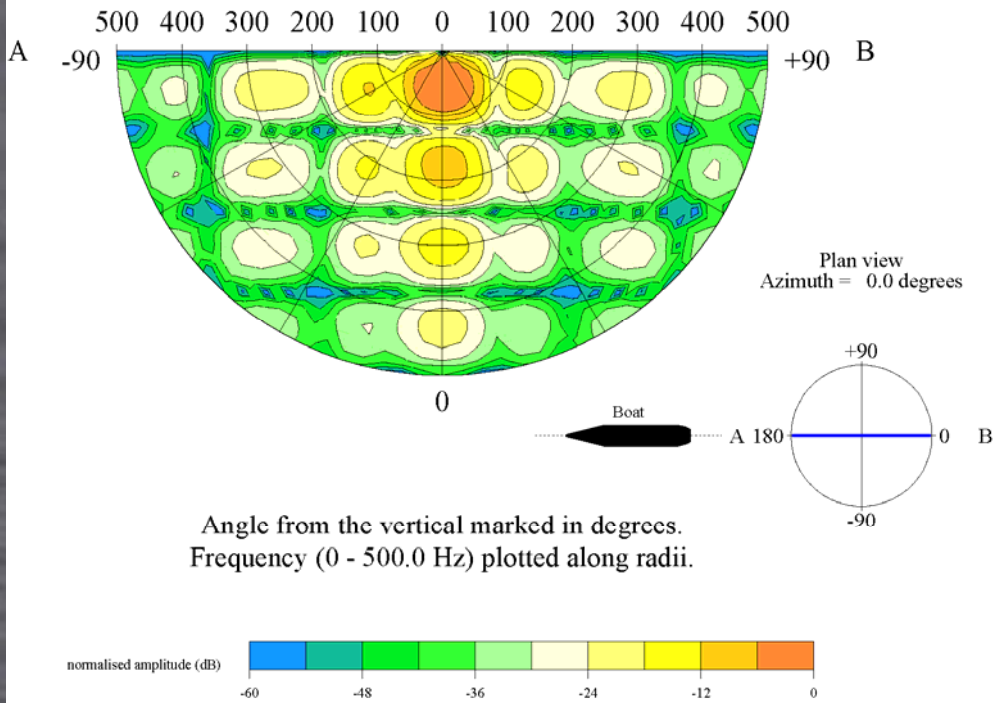

Inline

Source Directivity Plot - azimuth : 90.0 degrees - array odoptu_test_6

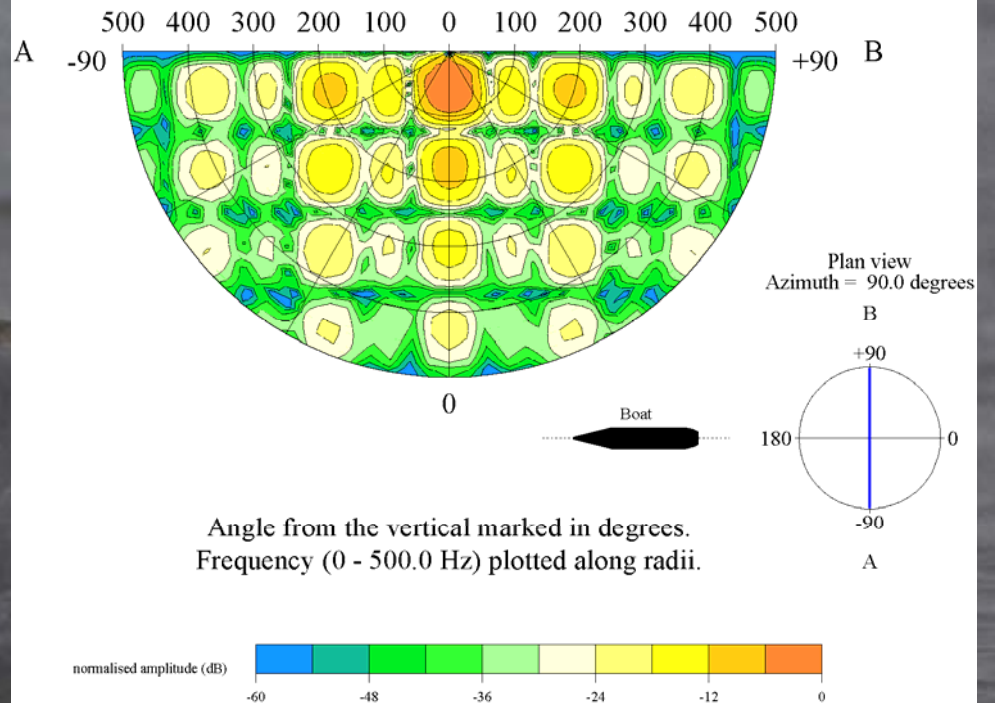

Cross-line



Seismic Sound Modelling Verification Against ENL 2001 Measurements

Roberto Racca

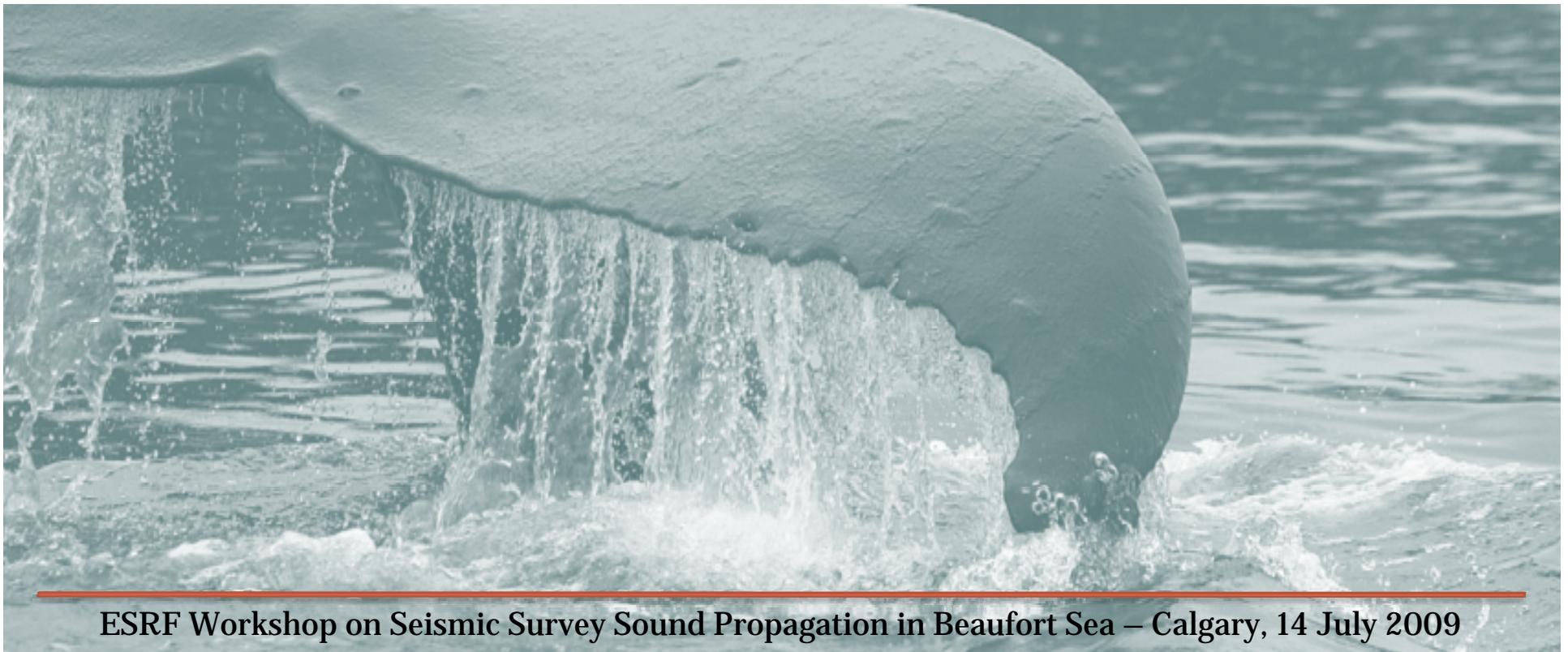

ESRF Workshop on Seismic Survey Sound Propagation in Beaufort Sea – Calgary, 14 July 2009

POI study of acoustic levels from 2001 seismic survey

- Survey line shot on 8.sep.01 with 1640 in³ airgun array in south to north direction
- Measurements performed at bottom depth using calibrated radio telemetry sonobuoys
- All six measurement stations located on 20m bathymetry contour

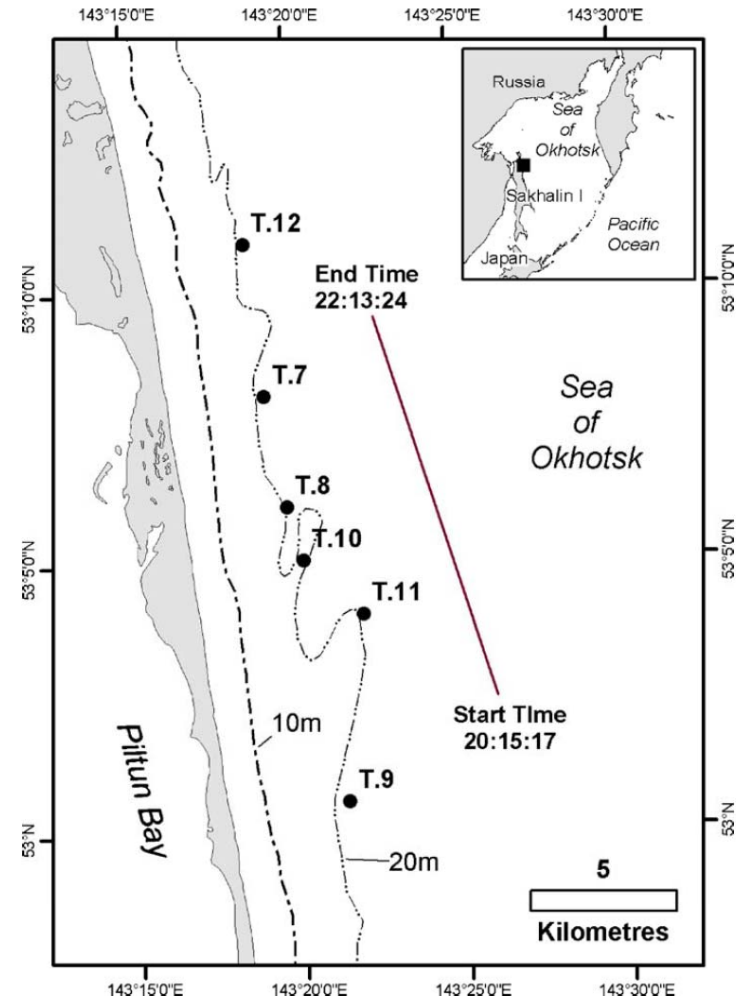

Modelled source characteristics of 1640 in³ array using AASM

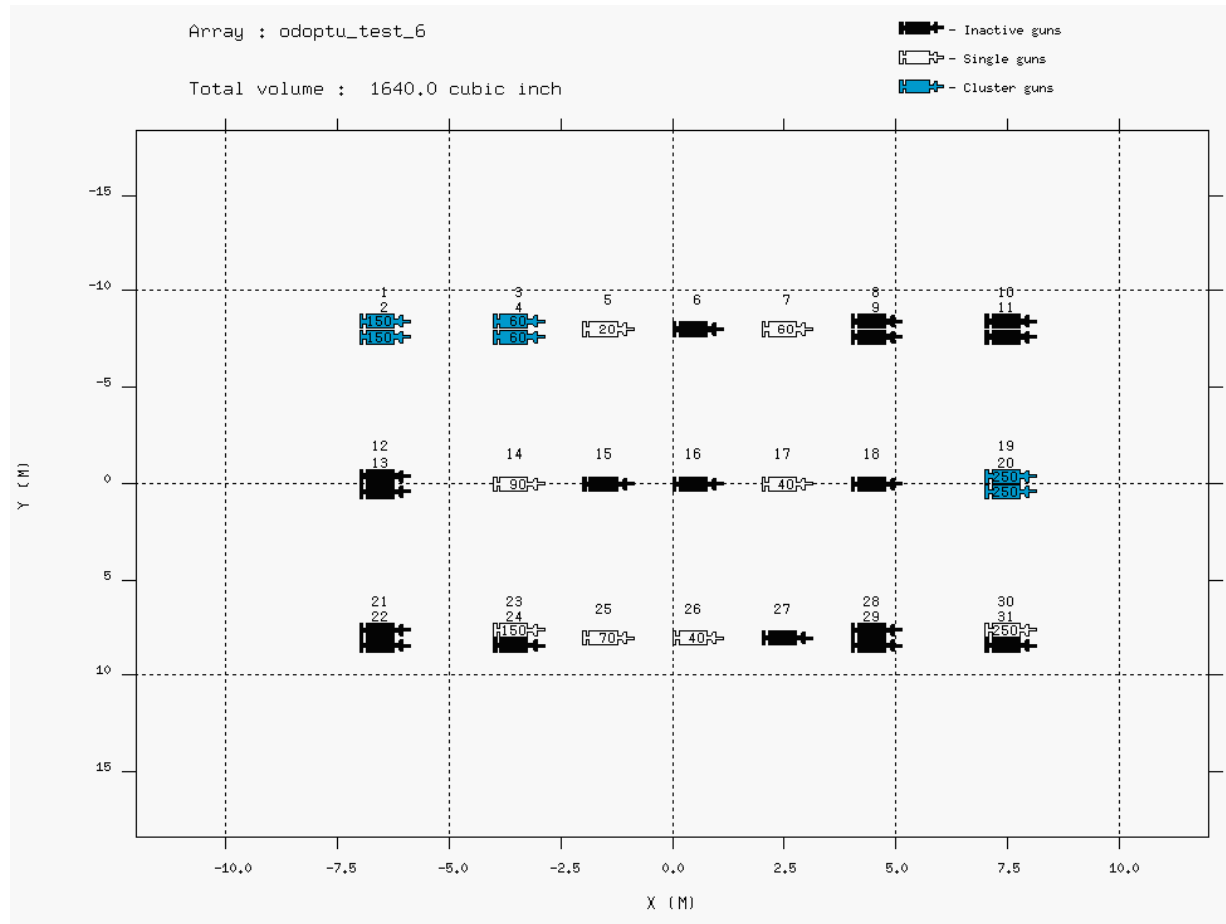

Parameters for seismic survey sound propagation modelling

Depth (m)	Sound Speed in water (m/s)
0.9	1469
2.5	1467
3.1	1466
5.1	1461
6.8	1456
8.0	1452
9.0	1448
10.2	1446
11.5	1444
32.0+	1444

Depth (mbsf)	Density (kg/m ³)	P-wave speed (m/s)	P-wave attenuation (dB/λ)	S-wave speed (m/s)	S-wave Attenuation (dB/λ)
0	1772	1652	0.14	150	13.6
500	1772	2152	0.14	150	13.6
>500	1772	2152	0.14	150	13.6

- Water sound speed profile obtained from typical CTD cast for early part of season
- Geo-acoustic profiles optimized against TL measurements; same as used for all prior industrial sound modelling in Piltun-Astokh

Measured & modelled sound levels vs. range at site T.7

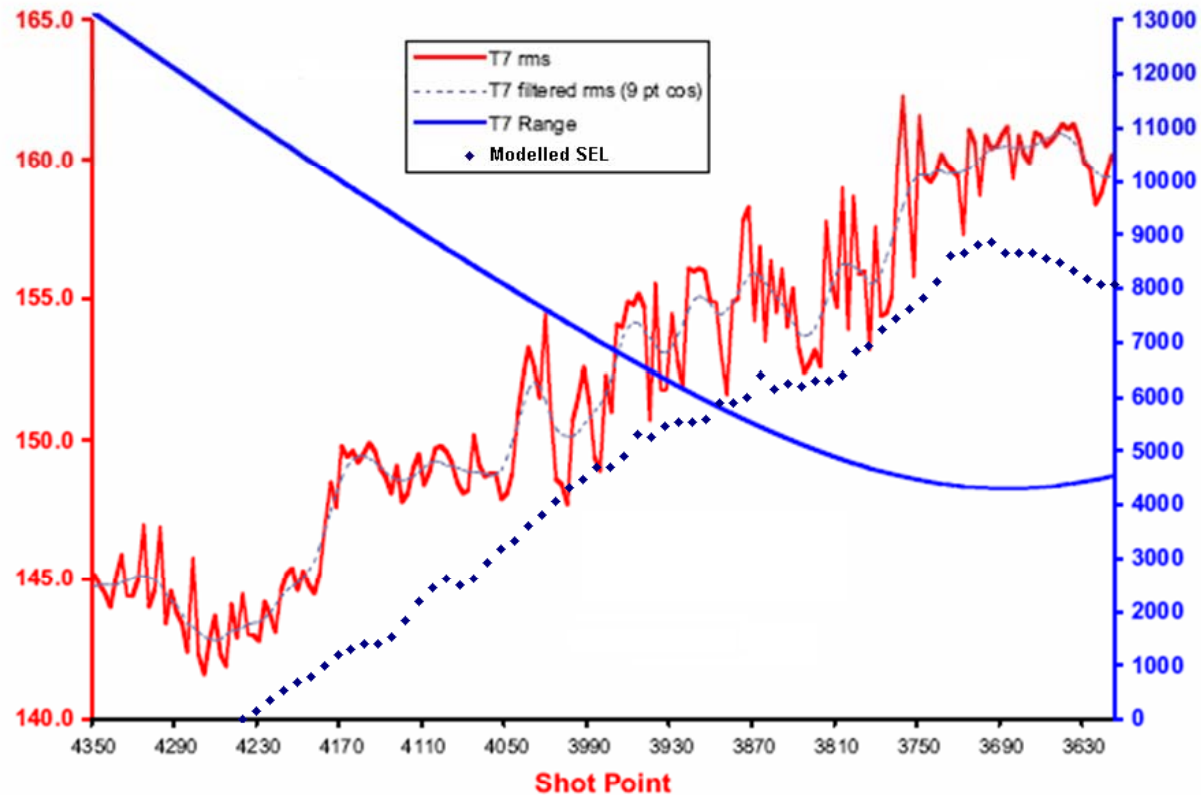

Measured & modelled sound levels vs. range at site T.8

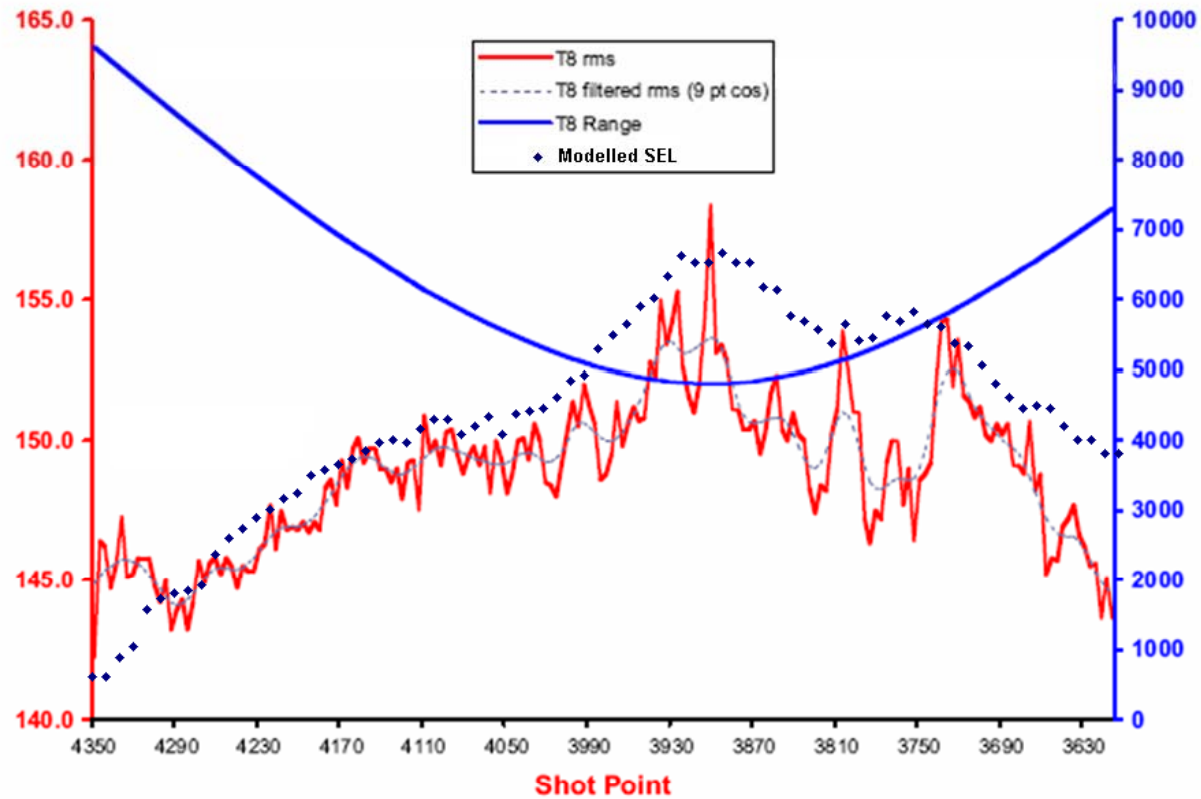

Measured & modelled sound levels vs. range at site T.9

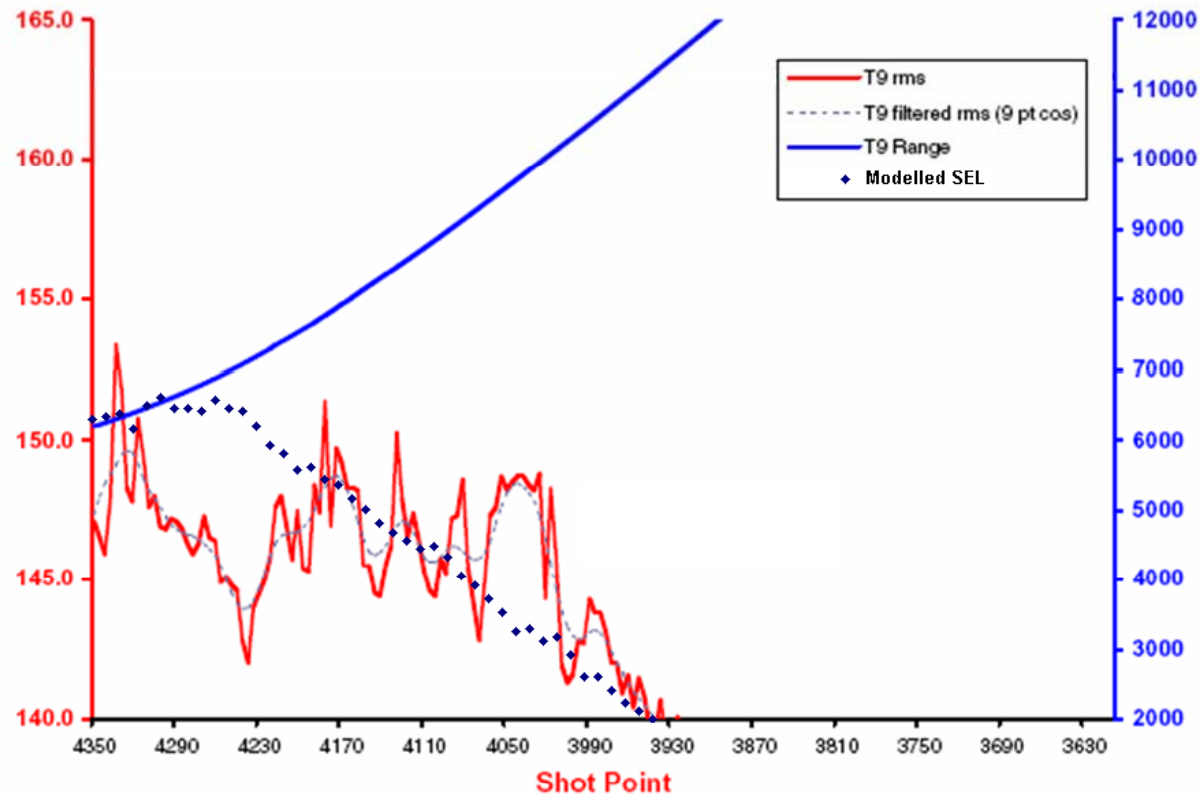

Measured & modelled sound levels vs. range at site T.10

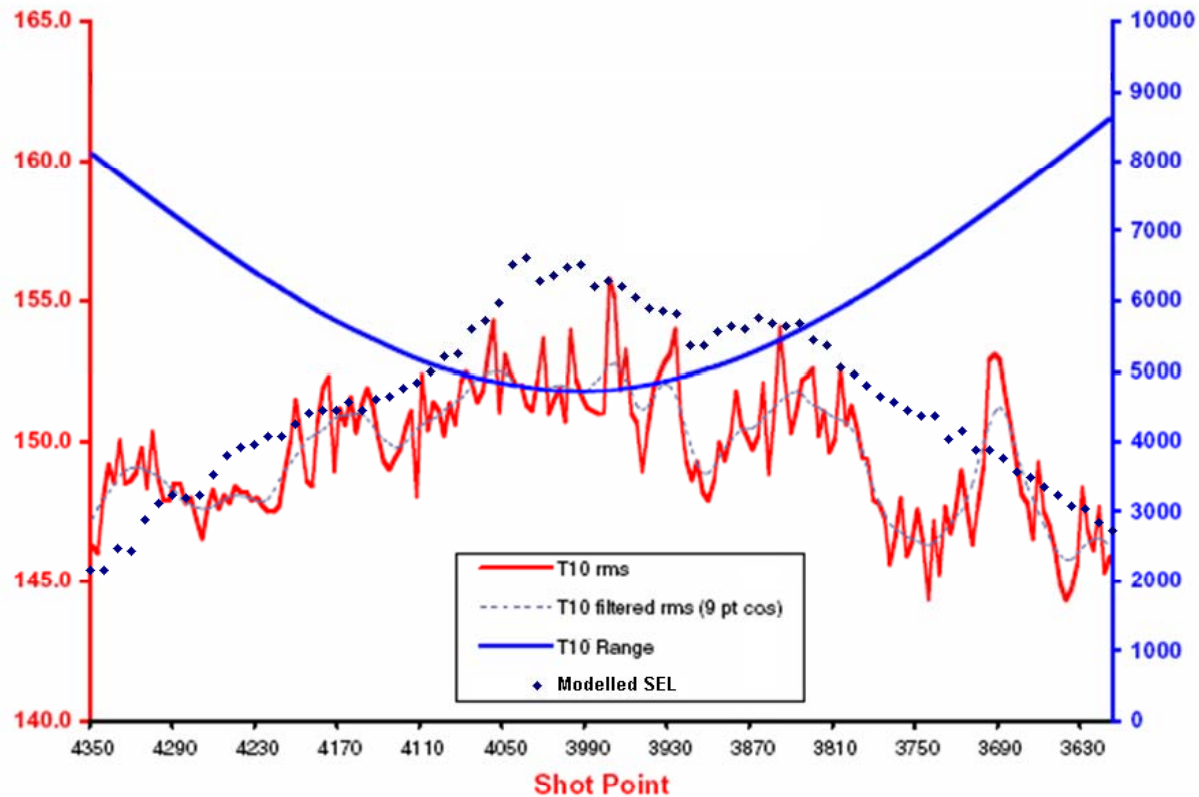

Measured & modelled sound levels vs. range at site T.11

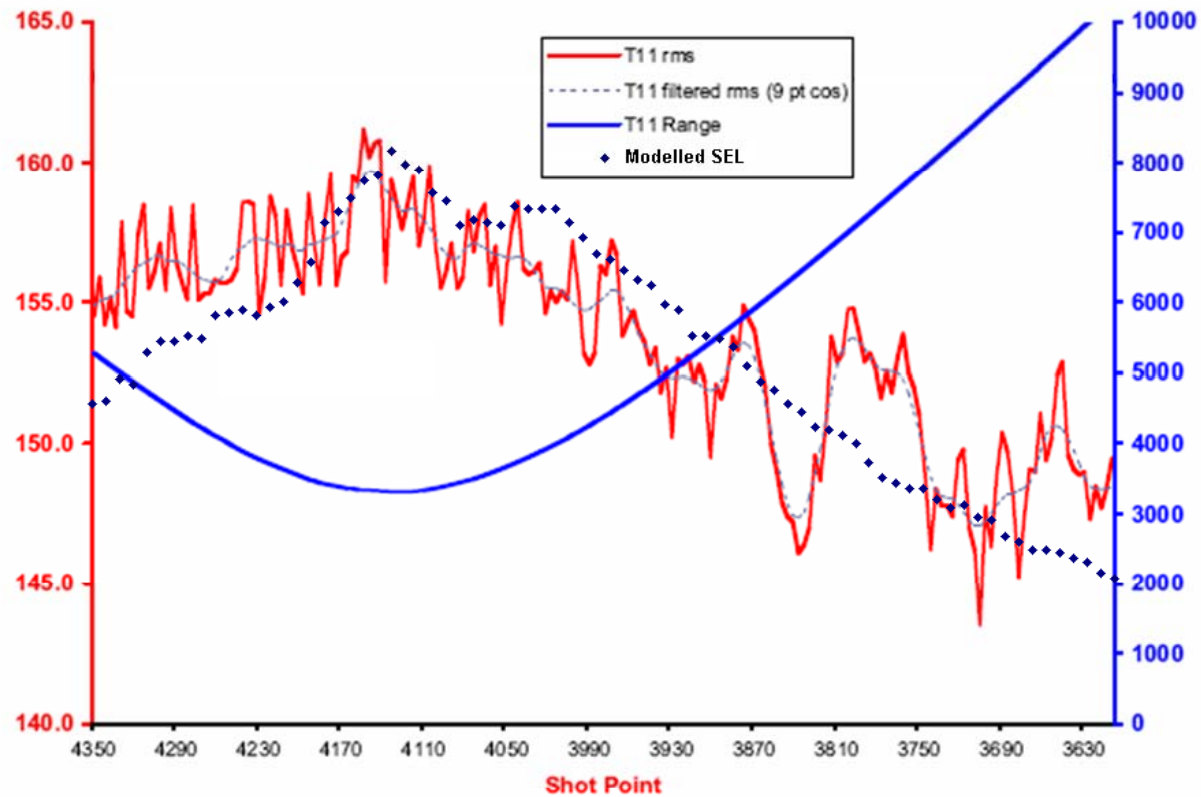

Measured & modelled sound levels vs. range at site T.12

